

# Haier

# Operation Manual Inverter Split Air Conditioner

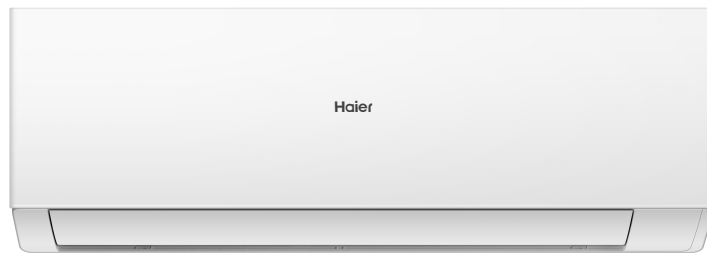

AS25QCFHRA  
AS35QCFHRA  
AS50QDFHRA

AS60QEEHRA  
AS71QEFHRA  
AS80QFFHRA

Please read this operation manual before using the air conditioner.  
Keep this operation manual for future reference.  
This appliance is filled with R32.

0010510062



# Contents

Warning	1
Features	2
Parts and Functions	3
Operation	4
Maintenance	9
Cautions	10

## Warning

This appliance contains a UVC lamp.

- Read the maintenance instructions before operating the appliance.
- Exposure to the top air inlet and inner part may cause eye or skin irritation. When performing maintenance tasks such as taking out or replacing the air filter, ensure that the power is switched off before approaching the product.
- The UVC barriers, marked with the ultraviolet radiation hazard symbol, must not be removed.
- Appliances that are obviously damaged must not be operated.
- Do not operate UVC lamps outside of the appliance.
- The appliance must be disconnected from the power supply before replacing or cleaning or other maintenance of the UVC lamp.
- The type of UV-C lamp is 0011022283A.
- The front panels, marked with the ultraviolet radiation hazard symbol and containing UVC radiation, are equipped with a switch to deactivate the power to the UVC lamps for safety purposes. Do not attempt to override the switch using magnets or similar materials.
- Prior to opening front panels marked with the ultraviolet radiation hazard symbol for user maintenance, it is advisable to disconnect the power source.
- To prevent any hazard, if the UVC lamp is damaged, it should be replaced by the manufacturer, its service agent, or similarly qualified individuals.
- Unintended use of the appliance or damage to the housing may result in the escape of dangerous UVC radiation. UVC radiation may, even in small doses, cause harm to the eyes and skin.
- Misuse of the appliance or damage to its housing may lead to the release of hazardous UVC radiation. Even in small amounts, UVC radiation can cause harm to the eyes and skin.





# Features



Coanda Plus Airflow



## Further, Faster, Stronger Cools Every Corner of the Room

Makes the wind out of the air conditioner further, faster, and stronger, so that the cool air can be evenly delivered to every corner of the room.

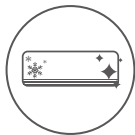

Self-Clean



## Always Clean Always Cool

Freezing the evaporator and condenser with moisture in the air, and rapidly melting away dirt ensures that the air coming out of the air conditioner is always healthy for you.



UVC Pro Sterilization



## Improved Purity Improved Living

Haier UVC Pro inhibits bacteria and viruses in the air, purifies the air by emitting UV-C band ray and generating positive and negative ions group.



# Parts and Functions

## Indoor Unit

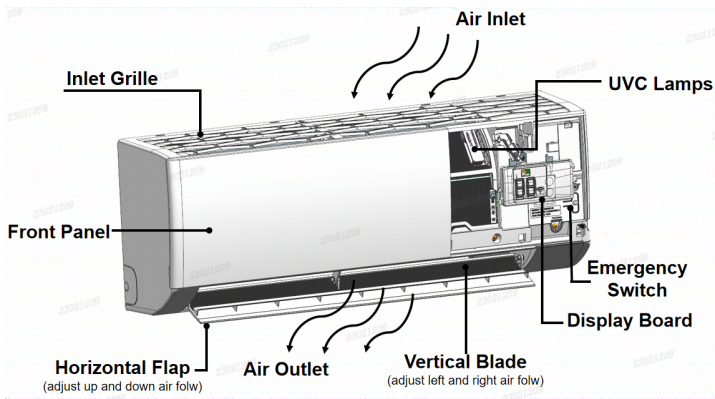

### Display board

- ① Signal receiver
- ② Setting temp. display
- ③ Operation mode indicator
- ④ Wi-Fi



Indicator lamp colour	Operation mode
Blue	COOL/DRY
Peach	HEAT
Cyan	HEALTH
No	FAN

Actual inlet grille may vary from the one shown in the manual according to the product purchased.

## Outdoor Unit

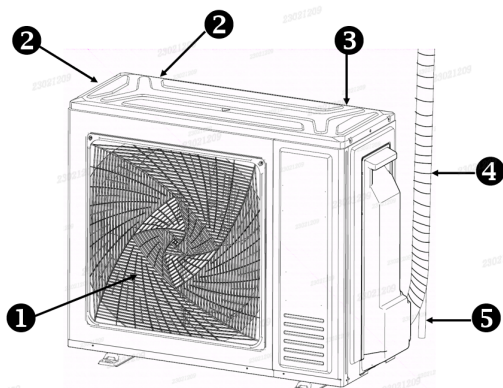

- ① Air Outlet
- ② Air Inlet
- ③ Outdoor temperature sensor
- ④ Connecting Piping and Electrical Wiring
- ⑤ Drain Hose

The outdoor unit may vary depending on the specific product purchased. The image above is provided for reference purposes.

## Remote Controller

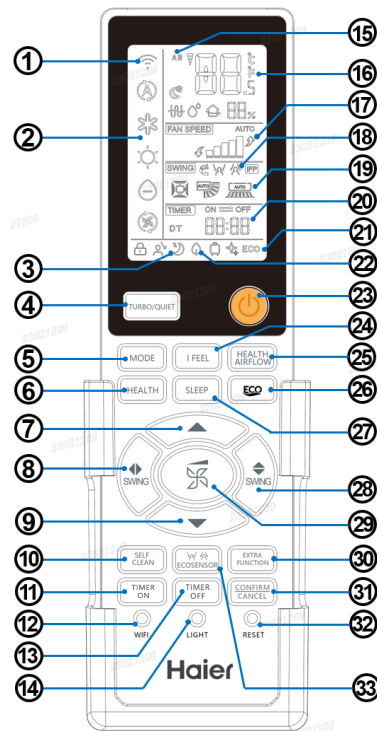

- 10. SELF CLEAN button
- 11. TIMER ON button
- 12. WIFI button
- 13. TIMER OFF button
- 14. LIGHT button
- 15. A/B yard
- 16. TEMP display
- 17. Fan Speed display
- 18. Sensor display
- 19. Swing display:
- 20. Timing display:
- 21. ECO display
- 22. Health display
- 23. POWER ON/OFF button
- 24. IFEEL button
- 25. HEALTH AIRFLOW button
- 26. ECO button
- 27. SLEEP button
- 28. SWING UP/DOWN button
- 29. FAN SPEED button
- 30. EXTRA FUNCTION button
- 31. CONFIRM CANCEL button
- 32. RESET button
- 33. ECO-SENSOR button

- 1. Signal display
- 2. Mode display
- 3. Sleeping display
- 4. TURBO/QUIET button
- 5. MODE button
- 6. HEALTH button(UVC starts working)
- 7. TEMP "+" button
- 8. SWING LEFT/RIGHT button
- 9. TEMP "-" button

**NOTE:** During HEAT mode, warm air will begin to blow out after a brief delay, thanks to the cold-draft prevention function. The duration of this delay is determined by the ambient temperature.

## Remote Controller

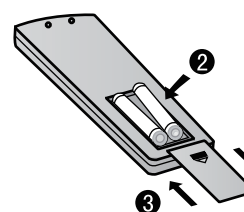

- 1 Remove the battery cover.
- 2 Load the batteries as illustrated. 2 R03 batteries, resetting key (cylinder).
- 3 Be sure that the loading is in line with the "+ /" -".
- 4 Load the battery, then put on the cover again.

- To reset the unit, follow these steps:
  - Turn off the unit.
  - Press the reset button on the remote. The screen will display multiple icons before returning to a blank screen with the time flashing as 12:00.
  - Use the up/down buttons to adjust the time.
  - Once the correct time is set, press the confirm/cancel button on the remote.
- Ensure that the distance between the signal transmission head and the receiver hole is within 7m without any obstacles. If electronic devices like fluorescent lamps or wireless telephones are present in the room, keep the distance shorter.
- If the display appears incomplete or unclear during operation, it indicates that the batteries are depleted. Replace the batteries.
- If the remote controller malfunctions during operation, remove the batteries and wait several minutes before reinstalling them.



# Operation

## Unit Start/Stop

### Remote controller

#### 1. Unit start

Press ON/OFF on the remote controller, unit starts.

#### 2. Select operation mode

COOL : Refrigeration mode  
HEAT : Heating mode  
DRY : Dehumidification mode  
FAN : Air supply mode  
AUTO: Automatic mode

#### 3. Select temp. setting

Press ▲ / ▼ button

▲ Every time the button is pressed, temp. setting increase 1°C, if kept depressed, it will increase rapidly.

▼ Every time the button is pressed, temp. setting decrease 1°C, if kept depressed, it will decrease rapidly.

Select a desired temperature.





#### 4. Fan speed selection

Press  button. For each press, fan speed changes as follows:

Remote controller: TURBO → QUIET → Original State



The air conditioner operates at the displayed fan speed. When the FAN mode is set to AUTO, the air conditioner automatically adjusts the fan speed based on the room temperature.

Operation Mode	Remote Controller	Note
AUTO		Under the mode of auto operation, air conditioner will automatically select Cool or Heat operation according to room temperature. When FAN is set to AUTO, the air conditioner automatically adjusts the fan speed according to room temperature.
COOL		Cooling only unit do not have displays and functions related with heating.
DRY		In DRY mode, if the room temperature drops below the temperature setting by 2°C, the unit will intermittently run at LOW speed, regardless of the FAN setting.
HEAT		In HEAT mode, warm air will begin to blow out after a short delay due to the cold-draft prevention function.
FAN		In FAN operation mode, the unit operates solely in FAN mode, without COOL or HEAT functions. AUTO mode is unavailable in FAN mode, and temperature setting is disabled. Additionally, SLEEP operation is not available in FAN mode.

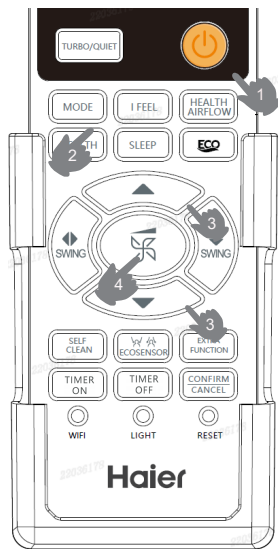

## Air Flow Direction Adjustment

### 1. Up and down air flow direction

For each press of SWING  button, the air flow direction on the remote controller displays as follows according to different operation modes:

COOL/DRY/FAN: 

AUTO: 

HEAT: 

### 2. Left and right air flow adjustment

For each press of SWING  button, remote controller displays as follows:  
remote controller:



### CAUTIONS:

- Always turn off the unit before adjusting the flap by hand.
- In conditions of high humidity, condensate water may accumulate at the air outlet if all vertical louvers are adjusted to the left or right.
- Avoid keeping the horizontal flap in a downward position for extended periods in COOL or DRY mode, as this may lead to condensate water formation. Upon restarting after remote turning off, the remote controller will automatically return to the previously set swing position.
- When healthy airflow function is set, the left and right air flow adjustment function can't be set up.

## TURBO/QUIET Operation

### 1. TURBO Operation

When you require rapid heating or cooling, you can activate the TURBO function. Press the TURBO/QUIET button, and the remote controller will indicate the activation of the TURBO function . Pressing the TURBO/QUIET button again will deactivate the TURBO function.

### 2. QUIET Operation

When silence is required for rest or reading, you can utilize the QUIET function. Press the TURBO/QUIET button, and the remote controller will indicate the activation of the QUIET function . Pressing the TURBO/QUIET button again will cancel the QUIET function.

For each press, the function changes as follows:

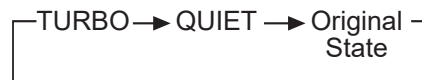









### NOTE:

- During POWER operation, in rapid COOL mode, the room may exhibit an inhomogeneous temperature distribution.
- Prolonged QUIET operation may result in a less pronounced cooling or warming effect.

# Operation

## Timer On/Off On-Off Operation

- After unit starts, select your desired operation mode.
- Press  /  button to change **TIMER**.  
Press  button "TIMER ON " will appear, after 10 seconds the time display will be blank.  
Press  button "TIMER OFF " will appear, after 10 seconds the time display will be blank.  
Then select your desired TIMER mode(TIMER ON or TIMER OFF). " ON "or" OFF " will flash.
- Press  /  button to set time.  
Each press will increase or decrease the time by 1 minute. If the button is held down, the time will change rapidly.
- Confirm timer setting.  
After adjust the time, press  to confirm, and the time ON or OFF button will stop flashing.
- Cancel timer setting.  
Press the  button to eliminate the time display.

### NOTE:

- After replacing batteries or experiencing a power failure, the time setting needs to be reset.
- Following the time setting sequence for "TIME ON" or "TIME OFF," you can achieve either a Start-Stop or Stop-Start function.

## SELF-CLEAN Operation

**FUNCTIONAL DESCRIPTION:** The purpose of this function is to clean the **evaporator** and **condenser**.

**TECHNOLOGY:** Dirt tends to accumulate on the evaporator during operation. If not cleaned regularly, this accumulation can lead to the growth of mold and bacteria, which can compromise the air quality provided by the air conditioner. Moreover, it can reduce the efficiency of the air conditioning system by **15-30%**.



### Cold Expansion

Occurs when frost forms on the evaporator/condenser, generating a strong force that can effectively peel off dirt from the surface.

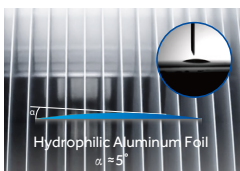

### Express Washing



Hydrophilic aluminum with a smaller angle enhances water drainage efficiency by 20%.



### Anti-bacteria

The coating on the aluminum contains silver nanoparticles that efficiently eliminate bacteria and inhibit their growth with over 99.99% effectiveness.

## SELF-CLEAN Operation

**ENTRY and EXIT:** To activate this function, press  button. "CL" will be displayed on both the panel of the indoor unit and the remote controller. After running for 20-30 minutes, the function will exit automatically, indicated by two "Pi" sounds. The unit will return to its original state. During the self-cleaning process, pressing the button repeatedly will have no effect, and the function will not exit. However, pressing the "POWER" button  or switching to another mode can exit the self-cleaning function.

### NOTE:

- This function is not available in TIMER/SLEEP mode.
- After activating this mode, the air volume may decrease or even stop altogether, and cold airflow may occur.
- It's normal for the unit to make sounds like expanding with heat and contracting with cold.
- If the outside ambient temperature drops below zero, error code "F25" may occur during self-cleaning operation. This is a normal protective measure. Please turn off the power and restart after 10 seconds.
- The optimal conditions to run this mode are: indoor temperature between 20°C and 27°C, indoor humidity between 35% and 60%, and outdoor temperature between 25°C and 38°C during the cooling season.
- It's difficult for frost to form if the air is too dry (humidity < 20%). Conversely, if the humidity is too high (humidity > 70%), condensate water may increase and remove some frost.

## Emergency operation and Test operation

### Emergency Operation:

- Use this operation only when the remote controller is defective or lost, and with the emergency running function, the air conditioner can operate automatically for a limited period.
- When the emergency operation switch is pressed, a single "Pi" sound is heard, indicating the start of this operation.
- Upon the initial power switch activation and the start of emergency operation, the unit will automatically operate in the following modes:

Room Temperature	Designated Temperature	Timer Mode	Fan Speed	Operation Mode
Above 23°C	26°C	No	AUTO	COOL
Below 23°C	23°C	No	AUTO	HEAT

- Operating in dry mode is not possible during emergency operation.



### Test Operation:

- Test operation switch is the same as emergency switch.
- Use the switch for test operation only when the room temperature is below 16°C; do not use it during normal operation.
- To initiate the test operation, continue pressing the test operation switch for more than 5 seconds. After hearing the "Pi" sound twice, release your finger from the switch. The cooling operation will start with the air flow speed set to "Hi".
- The test operation will automatically end after 30 minutes.



# Operation

## Comfortable SLEEP

Press the  button, and the remote controller will indicate the activation of the sleep function by displaying . Pressing  again will cancel the sleep function.



### Operation Mode

#### 1. In COOL/DRY mode

1 hour after SLEEP mode starts, the temperature will increase by 1°C compared to the temperature setting. After another hour, the temperature will rise by an additional 1°C. The unit will continue to run for an additional 6 hours before stopping. This prevents the room temperature from becoming too low during your sleep.

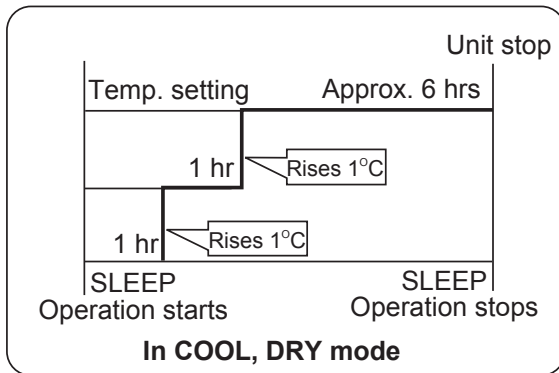

#### 2. In HEAT mode

1 hours after SLEEP mode starts, temp will become 2°C lower than temp. setting. After another 1 hours, temp. decrease by 2°C further. After more another 3 hours, temp. rises by 1°C further. The unit will run for further 3 hours then stops. Temp. is lower than temp. setting so that room temperature won't be too high for your sleep.

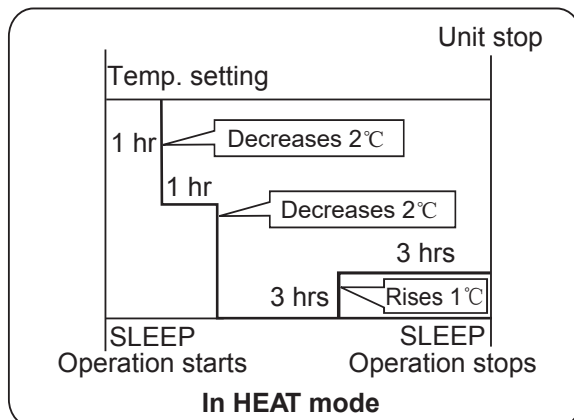

## Comfortable SLEEP

#### 3. In AUTO mode

The unit operates in the corresponding sleep mode adapted to the automatically selected operation mode.

#### 4. In FAN mode

The unit does not have a SLEEP function.

5. When the quiet sleeping function is set to 8 hours, the quiet sleeping time cannot be adjusted.

#### 6. Set the wind speed change when sleeping:

- If the wind speed is high or medium before setting for sleep, adjust it to low wind speed after sleeping.
- If it is already set to low wind speed, no change will occur.

### NOTE:



When the TIMER function is set, the quiet sleeping function cannot be activated. If the sleeping function is set up and the user resets the TIMER function, the sleeping function will be canceled, and the unit will be in the timing-on state. If both modes are set up simultaneously, and either of their operation times ends first, the unit will stop automatically, and the other mode will be canceled.



## Healthy Airflow Operation

1. Press  to start and set the comfort working conditions.

2. The setting of the healthy airflow function:

Press  again. Both the inlet and outlet grills of the air conditioner will open, and the unit will continue operating under the previous airflow function setting. After stopping, the outlet grille will automatically close.

1) Press ,  appears on the display to prevent strong airflow from directly blowing onto the body.

2) Press ,  appears on the display to avoid strong airflow from directly blowing onto the body.

3. Cancelling the Healthy Airflow Function

Press the button of health airflow again, both the inlet and outlet grills of the air conditioner are opened, and the unit goes on working under the condition before the setting of airflow function. After stopping, the outlet grille will close automatically.

### NOTE:

▲ Avoid manually adjusting the flap, as it may cause the grille to operate incorrectly. If the grille is not functioning properly, stop it for a minute and then restart, adjusting using the remote controller.

▲ In heating mode, it is preferable to select  mode.



▲ In heating mode, it is preferable to select  mode.

▲ In cooling and dry mode, if the air conditioner is used for an extended period under high humidity, condensate water may occur at the grille.

▲ When healthy airflow function is set, the left and right air flow adjustment function can't be set up.

# Operation

## HEALTH Operation

Press the  button, and the remote controller will display "  " to activate the health function. To cancel the function, simply press the  button again.



### TECHNOLOGY:

Haier UVC Pro utilises UVC-band rays at the air inlet. Direct exposure to these rays destroys the DNA and RNA structure of bacteria and viruses in the air as it passes through the air inlet. Additionally, UVC Pro can stimulate H<sub>2</sub>O nano and O<sub>2</sub> in the air, generating positive and negative ion groups that purify the air.

### NOTE:

1. It is advisable to activate the UV sterilization function for 1-2 hours per day. Prolonged use may impact the lifespan of the UVC lamp.
2. Avoid direct exposure to the UVC lamp or touching it when the sterilizing function is active. Remember to turn off the sterilizing function before opening the panel.
3. A tinged blue light may be visible near the air conditioning inlet when the sterilizing function is activated.
4. The UVC lamp will only be illuminated when the internal fan starts and the health function is turned on.

## IFEEL Operation

1. This function is available only in cooling, heating, or auto mode (other modes cannot be implemented).
2. Position the remote controller within the acceptable range of the air conditioner. Press the  button, and the remote control will display  . The remote controller sends the circulation temperature data to the indoor unit every 3 minutes, and the air conditioner operates according to this data.
3. "IFEEL" mode can be exited by turning off the power, pressing the  button again, or switching to other modes.

### Comfortable Experience

This function optimises the working conditions of the air conditioner to deliver airflow at the best temperature for your comfort.

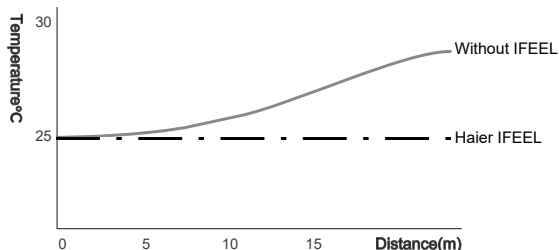

## LIGHT BUTTON

Manage the illumination and dimming of the indoor LED display board.

## ECO Operation

1. There are three layers of energy savings. When activated, the remote controller displays the power-saving symbol "  ".
2. Press this button to start the machine and initiate the initial refrigeration state. The temperature area shows "L1", followed by the set temperature after 5 seconds. Press "ECO" once during operation to display "L1" on the remote controller, followed by the set temperature after 5 seconds. The device operates at a 20% power-saving mode. Press "ECO" again while "L1" is displayed to switch to "L2"; the set temperature is displayed after 5 seconds, and the device operates at a 40% power-saving mode. Press "ECO" once more while "L2" is displayed to switch to "L3"; the set temperature is displayed after 5 seconds, and the device operates at a 60% power-saving mode. Press "ECO" again to exit "ECO" mode.
3. Press "ECO" once to display the current gear and the set temperature.
4. In air supply mode, the "ECO" key is inactive. Press the strong force, air supply, and shutdown buttons to exit the third-gear power mode.
5. When "ECO" mode is set to L3, the 60% power-saving mode may affect the refrigeration/heating effect. It is recommended that users choose L2 or L1 according to their needs to balance comfort and energy-saving.  
Note: This function is available in Cooling Mode. Capacity may decrease when Energy Control mode is selected.

**Notes:**When Energy Control mode is selected in Cooling Mode, there may be a decrease in capacity. Please note that this function is unavailable on some models. The Energy Control mode can be set only when the device is powered on.

## WIFI BUTTON

Press the button to enter WIFI binding mode. This indicates that your device is ready to connect.

**NOTE:** (This function is unavailable on some models)

## RESET BUTTON

If the remote control is not functioning properly, press this button to reset the remote.

## DRED Operation

Haier Peak smart enabled air-conditioners have a Demand Response Mode display on the indoor unit. The display could be labelled d1, d2, d3 (wording may differ model to model).

These modes are described in more detail below:

### Notes:

When self-clean mode is set, entering DRED mode will exit self-clean mode. When DRED mode is set, you cannot enter self-clean mode.



# Operation

Mode	Display	Description	What to do
DRM3	d3	Your air-conditioner will continue to cool or heat during the peak demand event. The energy consumed by your air-conditioner is capped at 75%.	No action is required.
DRM2	d2	Your air-conditioner will continue to cool or heat during the peak demand event. The energy consumed by your air conditioner is capped at 50%.	No action is required.
DRM1	d1	Your air conditioner is still turned on, and the fan will continue to operate. However, the compressor is turned off, and cool/hot air will no longer be generated.	DRM1 mode is only activated during emergency demand management situations. This mode will automatically reset the device within 2 hours. If your air conditioner is in this mode for longer than 2 hours, please contact Energex on 13 12 53.

## WiFi Function Description

If your Air Conditioner (AC) has a Connected Appliance Information label located under the front cover as shown below, your AC is WiFi Connect Enabled.

A WiFi communication card is built into the product allowing it to communicate with your smart phone for remote monitoring, control and notifications.

Please visit <https://www.haierhome.com.au> or <https://www.haierhome.co.nz> to learn more about connected appliance features, and to learn what connected appliance apps will work with your smart phone.

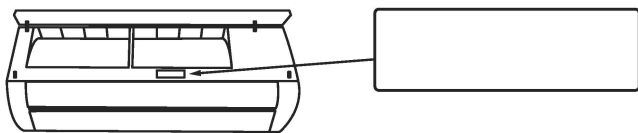

### Application software installation:

#### — Application Requirements:

A smart mobile phone and a wireless router are necessary for the application. The wireless router must be capable of connecting to the Internet.

#### — Configuration method

Please scan the QR code below to download the "SmarthQ" app. Once downloaded, please register, connect the air conditioner, and enjoy using "SmarthQ" to manage your device.



### Options of connecting conditioner to your smart phone

Please note: With the "SmarthQ" app installed on your phone and an app account registered.



- 1 Turn on your phone's Bluetooth.
- 2 Put the device into configuration mode: the WiFi indicator light should flash on the device.
- 3 Open the "SmarthQ" app, click the plus sign in the upper right corner, and enter the device add page.
- 4 Select the device found under "NEARBY", click "Connect", and the first binding will prompt Bluetooth pairing.
- 5 Select the network that you want to connect to, enter the password of the network, and click "CONNECT".

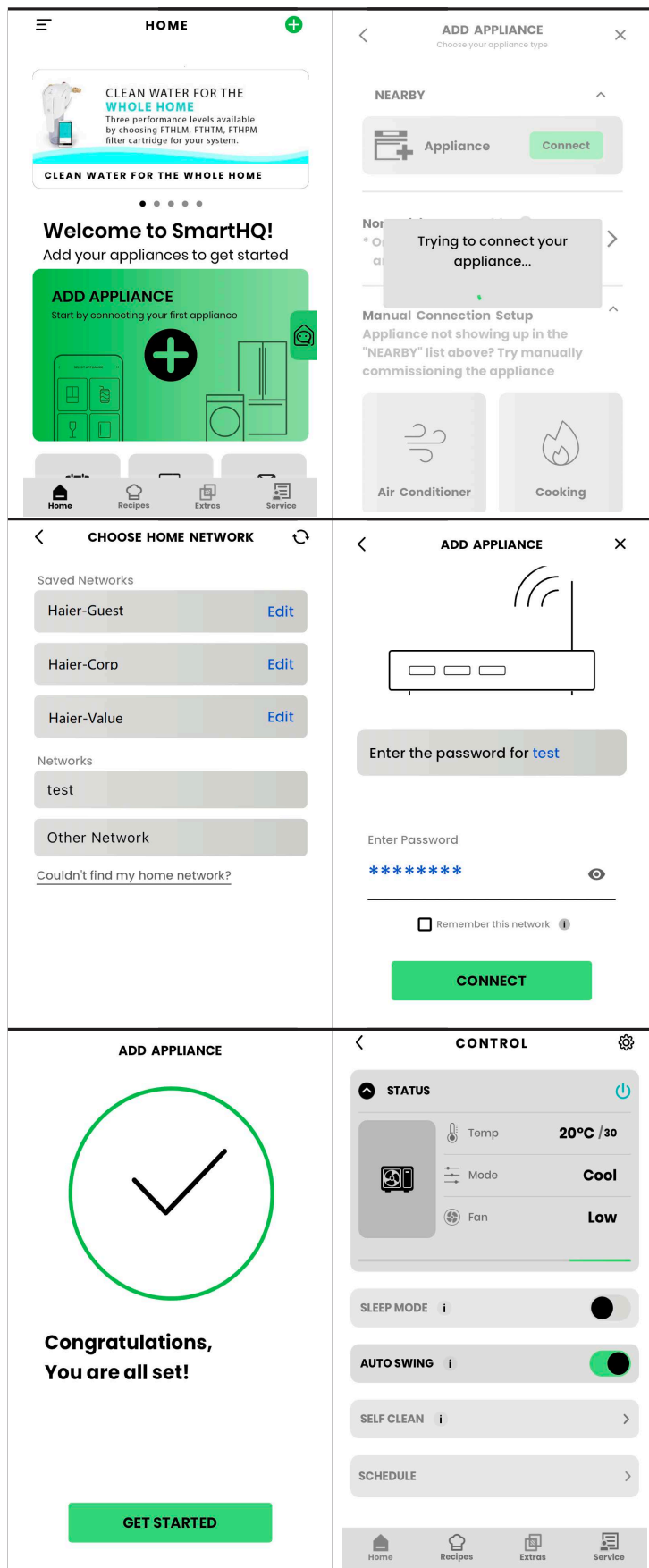



- 6 Wait for the device to bind successfully, and click GET STARTED.
- 7 After the fifth step is completed, automatically jump to the home page of the App, select the successfully bound device for control.

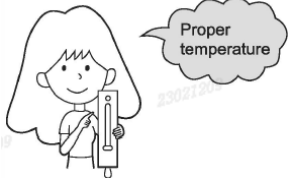
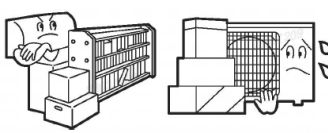
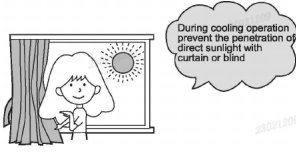
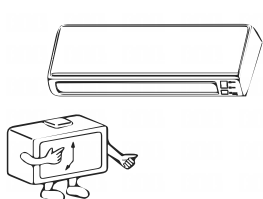

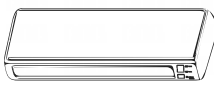
# Maintenance

## For Smart Use of The Air Conditioner

<p>Setting of proper room temperature.</p> 	<p>Do not block the air inlet or outlet.</p> 
<p>Close doors and windows during operation.</p> 	<p>Use the timer effectively.</p> 
<p>If the unit is to remain unused for an extended period, switch off the main power supply.</p> 	<p>Use the louvers effectively.</p> 

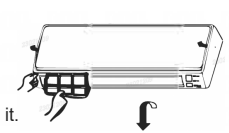
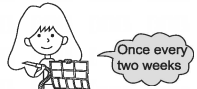
<p>Remote Controller</p>  <p>Avoid using water; instead, wipe the controller with a dry cloth. Refrain from using glass cleaner or chemical cloths.</p>	<p>Indoor Body</p>  <p>Wipe the air conditioner by using a soft and dry cloth. For serious stains, use a neutral detergent diluted with water. Wring the water out of the cloth before wiping, then wipe off the detergent completely.</p>
<p>Do not use the following for cleaning</p>  <p>Gasoline, benzene, thinner or cleanser may damage the coating of the unit.</p>  <p>Hot water over 40°C(104°F) may cause discoloring or deformation.</p>	
<p>Air Filter cleaning</p> <ol style="list-style-type: none"> <li>1 Pull the inlet grille upward to open it.</li> <li>2 Remove the filter. Gently push up the center tab of the filter until it releases from the stopper, then pull the filter downward to remove it.</li> <li>3 Clean the filter. Utilise a vacuum cleaner to eliminate dust, or wash the filter with water. After washing, thoroughly dry the filter in a shaded area.</li> <li>4 Attach the filter. Ensure proper attachment of the filter with the "FRONT" indication facing forward. Confirm that the filter is securely fixed behind the stopper. Incorrect attachment of the right and left filters may lead to defects.</li> <li>5 Close the inlet grille.</li> </ol>  	

## Replacement of Air Purifying Filter (NOTE: Air purifying filter is optional part)

- 1. Open the Inlet Grille**

Prop up the inlet grille by using a small device named grille-support which located in the right side of the indoor unit.

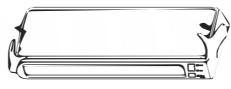
- 2. Detach the standard air filter**

Gently slide the knob upward to release it, then withdraw the filter.

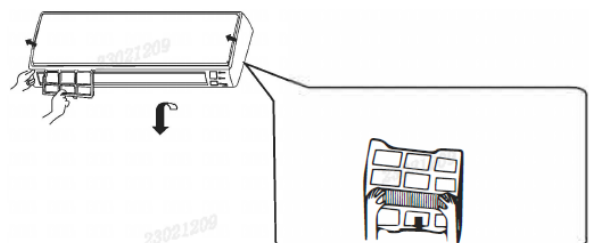
- 3. Attach Air Purifying Filter**

Put air purifying filter appliances into the right and left filter frames.

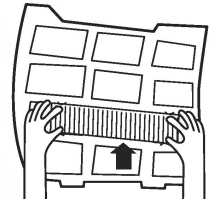

- 4. Attach the standard air filter (Necessary installation)**

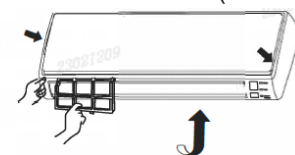

**ATTENTION:**  
Ensure the white side of the photocatalyst air purifying filter faces outward, while the black side faces the unit. Similarly, position the green side of the bacteria-killing medium air purifying filter outward, with the white side facing the unit.
- 5. Close the Inlet Grille**

Securely close the grille.

**NOTE:**

  - The photocatalyst air purifying filter will undergo solarization at regular intervals. In a typical household, this process occurs every 6 months.
  - The photocatalyst air purifying filter will undergo solarization at regular intervals. In a typical household, this process occurs every 6 months.
  - To maintain the effectiveness of the bacteria-killing medium air purifying filter, store it in cool, dry conditions, away from prolonged exposure to direct sunlight when not in use. This helps prevent a reduction in its sterilization capabilities.



# Cautions

## ⚠ WARNING

For installation, please contact Sales/Service Shop. Do not attempt to install the air conditioner yourself, as improper installation may result in electric shock, fire, or water leakage.

## ⚠ WARNING

If you notice any abnormalities such as a burnt smell, promptly cease operation by pressing the button and contact the sales shop for assistance.

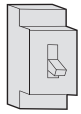

OFF



**!**  
**STRICT ENFORCEMENT**

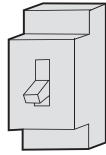

Use an exclusive power source with a circuit break.

**!**  
**STRICT ENFORCEMENT**

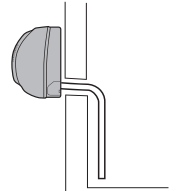

Check proper installation of the drainage.

1. Avoid using power supply cords that are extended or connected halfway.
2. Avoid installing the unit in areas where there is a risk of inflammable gas leakage.
3. Additionally, prevent exposure of
4. the unit to vapor or oil steam. **PROHIBITION**

Avoid inserting objects into the air inlet or outlet.

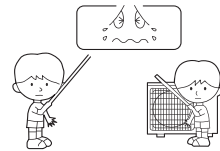

**PROHIBITION**

Do not start or stop the operation by disconnecting the power supply cord or similar methods.

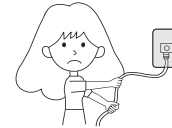

**PROHIBITION**

Avoid directing the airflow directly at people, especially infants or the elderly.

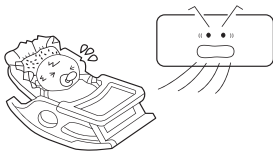

Do not attempt to repair or modify the unit by yourself.

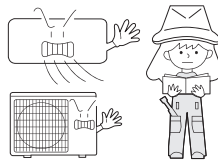

Connect the earth cable.

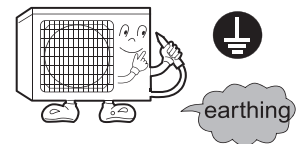

earthing



## ⚠ CAUTION

Do not use for storing food, artwork, precision equipment, breeding, or cultivation purposes.



**PROHIBITION**

Occasionally, ensure to take in fresh air, especially when a gas appliance is running simultaneously.

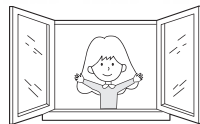

**!**  
**STRICT ENFORCEMENT**

Avoid operating the switch with wet hands.

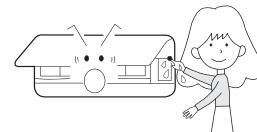

**PROHIBITION**

Do not install the unit near a fireplace or other heating apparatus.

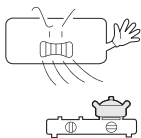

**PROHIBITION**

Check good condition of the installation stand

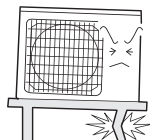

**PROHIBITION**

Do not pour water onto the unit for cleaning

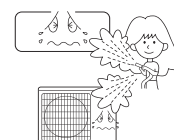

**PROHIBITION**

Avoid placing animals or plants directly in the path of the airflow.

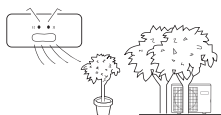

**PROHIBITION**

Do not place any objects on the unit or climb on it.







**PROHIBITION**

Avoid placing flower vases or water containers on top of the unit.



**PROHIBITION**

# Cautions

Trouble Shooting		
Item	Phenomenon	Cause or check points
	The system does not restart immediately. 	<ul style="list-style-type: none"> <li>After the unit is stopped, it will not immediately restart to protect the system; a 3-minute delay is required.</li> <li>When the electric plug is removed and reinserted, the protection circuit will activate for 3 minutes to safeguard the air conditioner.</li> </ul>
	Noise is heard. 	<ul style="list-style-type: none"> <li>During unit operation or at stop, a swishing or gurgling noise may be heard. At first 2-3 minutes after unit start, this noise is more noticeable. (This noise is generated by refrigerant flowing in the system.)</li> <li>During unit operation, a cracking noise may be heard. The noise is generated by the casing expanding or shrinking because of temperature changes.</li> <li>Should there be a big noise from air flow in unit operation, air filter may be too dirty.</li> </ul>
	Smells generated.	<ul style="list-style-type: none"> <li>This occurs because the system circulates odors from the indoor air, such as those from furniture, paint, or cigarettes.</li> </ul>
	Mist or steam are blow out. 	<ul style="list-style-type: none"> <li>During COOL or DRY operation, the indoor unit may emit mist. This is caused by the rapid cooling of indoor air.</li> </ul>
	In DRY mode, fan speed can't be changed.	<ul style="list-style-type: none"> <li>In DRY mode, when the room temperature drops below the set temperature by 2°C, the unit will intermittently operate at LOW speed, irrespective of the FAN setting.</li> </ul>
		<ul style="list-style-type: none"> <li>Is power plug inserted?</li> <li>Is there a power failure?</li> <li>Is fuse blown out?</li> </ul>
		<p>Is the air filter dirty?-Normally it should be cleaned every 15 days.</p> <p>Are there any obstacles before inlet and outlet?</p> <p>Is temperature set correctly?</p> <p>Are there some doors or windows left open?</p> <p>Is there any direct sunlight through the window during the cooling operation? (Use curtain)</p> <p>Are there too much heat sources or too many people in the room during cooling operation?</p>

## Cautions

- Avoid obstructing or covering the ventilation of the air conditioner. Do not insert fingers into the inlet/outlet or the swing louver.
- This appliance is not intended for use by individuals (including children) with reduced physical, sensory, or mental capabilities, or lack of experience and knowledge, unless they have been given supervision or instruction on how to use the appliance by a person responsible for their safety. Children should be supervised to ensure they do not play with the appliance.

### Specifications

- The refrigerating circuit is leak-proof.

The machine is adaptive in following situation

- Applicable ambient temperature range:

Cooling	Indoor	Maximum:D.B/W.B 32°C/23°C Minimum :D.B/W.B 21°C/15°C
	Outdoor	Maximum:D.B/W.B 46°C/26°C Minimum :D.B/W.B -10°C
Heating	Indoor	Maximum:D.B/W.B 27°C Minimum :D.B/W.B 15°C
	Outdoor	Maximum:D.B/W.B 24°C/18°C Minimum :D.B/W.B -10°C
	Outdoor (INVERTER)	Maximum:D.B/W.B 24°C/18°C Minimum :D.B/W.B -15°C

- If the power supply cord is damaged, it must be replaced by the manufacturer or its service agent or a similar qualified person.
- If the fuse of indoor unit on PC board is broken, please change it with the type of T.3.15A/ 250V. If the fuse of outdoor unit is broken, change it with the type of T.25A/250V.
- The wiring method should be in line with the local wiring standard.
- After installation, the power plug should be easily reached.
- The waste battery should be disposed of properly.
- The appliance is not intended for use by young children or infirm persons without supervision.
- Young children should be supervised to ensure that they do not play with the appliance.
- Please use the appropriate power plug that fits into the power supply cord.
- The power plug and connecting cable must have acquired the local attestation.
- To protect the units, please turn off the A/C first, and then wait at least 30 seconds before cutting off the power.

### Customer Care

Visit the website for more information

Australia: [haierhome.com.au](http://haierhome.com.au)

New Zealand: [haierhome.co.nz](http://haierhome.co.nz)

Customer support and service booking

Australia: 1300 729 948

New Zealand: 0800 424 372

Important notice of Disclosure: Copyright © Fisher & Paykel Appliances 2024. All rights reserved. The product dimensions and specifications in this document apply to the specific products and models described at the date of issue. Under our policy of continuous product improvement, these dimensions and specifications may change at any time. You should therefore check with your dealer or Haier's Customer Care Centre to ensure this flyer correctly describes the products currently available

Fisher & Paykel Appliances Australia, Level 1, 1 Eden Park Drive, Macquarie Park, NSW 2113.  
New Zealand: Fisher & Paykel Appliances Ltd, 78 Springs Road, East Tamaki, Auckland 2013.

# Haier