



PACIFIC BRACKETS

The Pro Pipe Pacific Bracket series has been designed for fast and easy installation. The partially assembled adjustable bracket is made of electro-galvanized steel with a powder coated finish.

Brackets are supplied with rust resistant bolts and anti-vibration rubber mounts.

*wall fixings not supplied

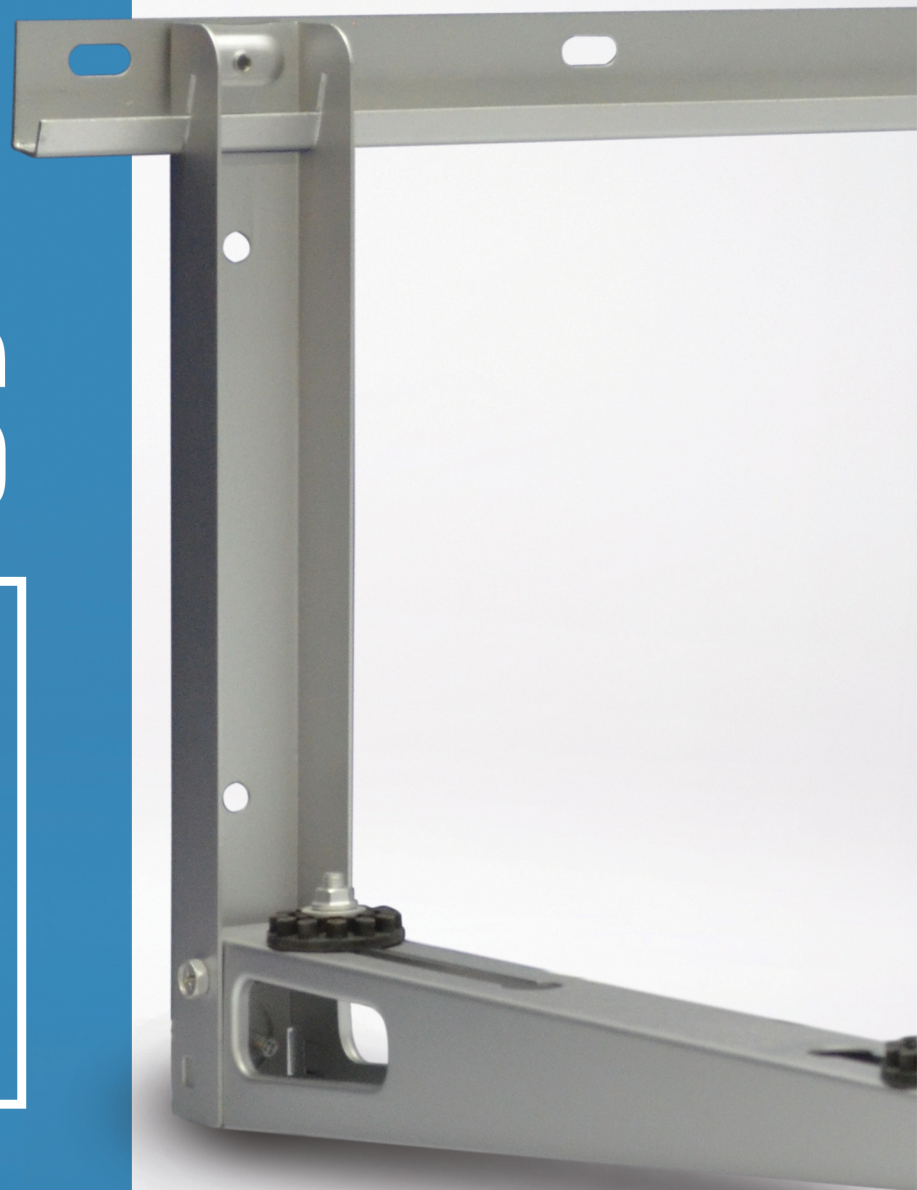

PACIFIC WALL BRACKETS

PART NO.	DIMENSIONS	WEIGHT
PSGK81	D450 x L800 x H380mm	100kg
PSGKL83	D550 x L800 x H420mm	150kg

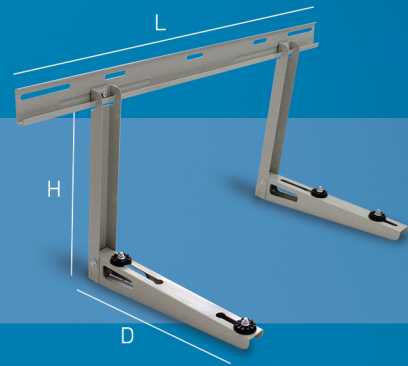

RUST RESISTANT WALL BRACKETS

PART NO.	DIMENSIONS	WEIGHT
PSGK81R	D450 x L800 x H380mm	100kg
PSGKL83R	D550 x L800 x H420mm	150kg

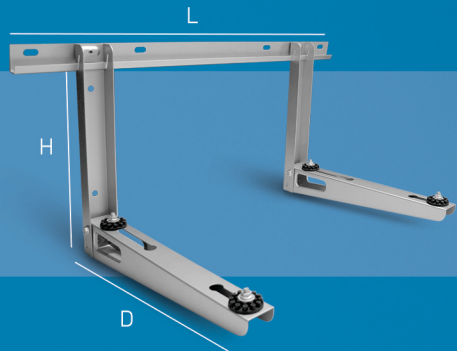

CANTILEVER STRUT BRACKET SETS

PART NO.	DIMENSIONS	WEIGHT
CB450	D490 x H280mm	150kg
CB600	D640 x H280mm	150kg
CB750	D790 x H280mm	150kg

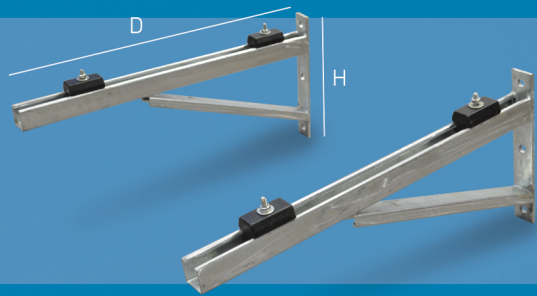

PACIFIC SLOPED ROOF BRACKETS

PART NO.	DIMENSIONS	WEIGHT
PSGY1	D400 x L730mm	100kg
PSGYL1	D750 x L600mm	150kg



PACIFIC CANTILEVER BRACKETS

PART NO.	DIMENSIONS	WEIGHT
PSGK2F	D450 x H380mm	100kg
PSGKL3F	D550 x H420mm	150kg

