

tyco

Electronics

Energy Division

Power Products Reference Manual



UTILUX

Utilux is a brand that has built an enviable reputation for high quality, reliable electrical connectors. For over 80 years, this dynamic Australian brand has been a leader in the field of interconnection systems. Utilux has now joined the truly innovative, international market leader, Tyco Electronics.

Our aim is to provide the best possible products and services to keep our customers at the cutting edge of industry standards - internationally.

QUALITY YOU CAN RELY ON

The Utilux manufacturing operation is certified to International Standards Organisation (ISO) 9001:2000 quality standards, the benchmark for the worlds best practice in design and production facilities and methods. Tyco's highly skilled technical team ensures that these optimal standards are inherent in every product that leaves our factories.

You can be sure that Utilux branded products are fabricated from the finest materials and produced to exacting tolerances. They represent the latest technology and the best design for the tasks they are required to perform.

RELIABLE ELECTRICAL CONNECTORS

Utilux is a leading brand of electrical connectors sold to original equipment manufacturers and electrical distribution companies throughout Australia, New Zealand and Asia. A comprehensive range, the most up to date production technology and the highest quality control standards ensure that there are Utilux connectors, of optimum reliability and durability, for all major power distribution applications.

TESTING FACILITY

Located within Tyco Electronics Energy Division's Wyong manufacturing facility is the largest NATA accredited test facility owned and operated by a manufacturing supplier within the Australian and New Zealand market place.

Full test facilities are available, whether electrical, mechanical or environmental.

RESEARCH & DEVELOPMENT

As part of the worlds largest electrical connector company, the development of products is an ongoing commitment.

It is done on a global basis, utilising the talents of many people throughout the organisation to ensure a global product for a local market.

TECHNICAL ASSISTANCE

Whether dealing direct with Tyco Electronics Energy Division or a Distributor, a full team of experienced technical sales and support people are available to assist in the purchase of products shown in the catalogue or to develop a solution to meet your particular needs.

CATALOGUE

This catalogue is correct at the time of printing but due to ongoing design reviews and product development, Tyco Electronics Energy Division reserves the right to modify the specification of any product without notice.

CONTENTS

PLEASE NOTE: To quickly navigate through this reference manual, click on the UTILUX Logo to return to this contents menu. To return to the Index page of a particular product range, click on the product range name that can be found in the top right hand side of the page, across from the UTILUX Logo.

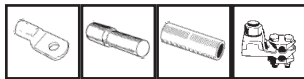

COPPER CONDUCTOR TERMINATIONS

SECTION 1

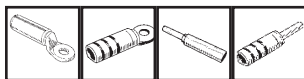

ALUMINIUM LUGS AND LINKS

SECTION 2

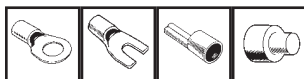
BI-METAL LUGS AND LINKS

SECTION 3

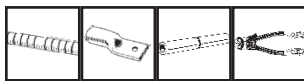
UNINSULATED & PREINSULATE TERMINALS

SECTION 4

OVERHEAD SLEEVES AND LUGS

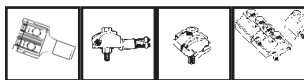
SECTION 5

BOLTED OVERHEAD CONNECTORS

SECTION 6

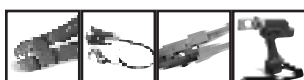

TERMINAL BLOCKS

SECTION 7

APPLICATION TOOLING

SECTION 8

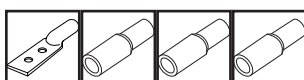
CABLE MANAGEMENT

SECTION 9

TECHNICAL & UTILUX EXPRESS

SECTION 10

INDEXES INCLUDING ALPHABETICAL, BY CATALOGUE NUMBER, BY DESCRIPTIVE NUMBER & FAST FIND

INDEX

SPARE PARTS LISTS

SPARE PARTS

INDEXES



MAIN INDEX

INDEX

1

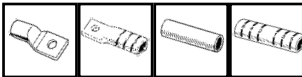

FAST FIND

INDEX

2

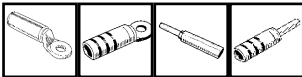

ALPHABETICAL INDEX

INDEX

3

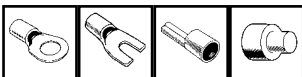

INDEX BY CATALOGUE NUMBER

INDEX

4

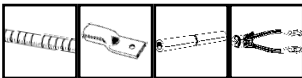

INDEX BY DESCRIPTIVE NUMBER

INDEX

5

CONTENTS

SECTION 1	COPPER CONDUCTOR TERMINATIONS.....1		
	COPPER CRIMP LUG.....2		
	CIRCUIT BREAKER LUGS.....4		
	COPPER FLARED LUGS.....5		
	COPPER CRIMP LINKS.....6		
	COPPER CRIMP LINKS – WITH SOLID BARRIER.....7		
	REDUCING LINKS.....8		
	COPPER STALK LUG – TYPE 1.....9		
	COPPER STALK LUG – TYPE 2.....9		
	CRIMP CABLE CONNECTOR.....9		
	CABLE LUG SOLDER TYPE.....10		
	SEALED COPPER CRIMP LUGS.....10		
	BOLTED CABLE LUG.....11		
	BOLTED TEE CLAMP.....11		
	CAST LUGS.....11		
	‘C’ CONNECTORS.....12		
	SOLID PALM COPPER LUGS.....13		
SECTION 2	ALUMINIUM LUGS AND LINKS.....15		
	UNILUG FOR ALUMINIUM CABLES.....16		
	UNILINK ALUMINIUM.....17		
	ELECTRICAL JOINTING COMPOUND.....17		
	3 & 4 CORE SECTOR LUG.....18		
	ROUND BARREL SECTOR.....18		
	3 & 4 CORE SECTOR LINK.....19		
	SECTOR TO ROUND LINK.....19		
	CCT CONDUCTOR.....20		
	ALUMINIUM ROTATING LUGS.....21		
SECTION 3	BI-METAL LUGS AND LINKS.....23		
	BI-METAL CRIMP LUG.....24		
	BI-METAL CRIMP LINK.....25		
	3 & 4 CORE SECTOR		
	BI-METAL LUG – (SOLID ONLY).....26		
	3 & 4 CORE SECTOR		
	BI-METAL LINK – (SOLID ONLY).....27		
	BI-METAL CRIMP STALK LUG.....28		
	3 & 4 CORE SECTOR		
	BI-METAL STALK – (SOLID ONLY).....28		
	BI-METAL ROTATING LUGS.....29		
	BI-METAL ROTATING LINK.....29		
	BI-METAL LONG PALM LUGS.....30		
	BI-METAL REVERSE LUGS.....30		
SECTION 4	BI-METAL LUGS AND LINKS NON-INSULATED PRE-INSULATED LUGS & LINKS.....31		
	UNINSULATED RING TERMINAL UTILUG.....32		
	PRE-INSULATED RING TERMINAL UTILUG.....33		
	RING TERMINAL SUPERGRIP UTILUG.....34		
	UNINSULATED FORK UTILUG.....35		
	SUPERGRIP FORK UTILUG.....35		
	PRE-INSULATED FORK UTILUG.....36		
	HIGH TEMPERATURE UTILUG RING TERMINAL.....36		
	HEAVY DUTY INSULATED RING TERMINAL.....37		
	BOOTLACE FERRULES.....37		
	DUAL BOOTLACE FERRULES.....37		
	UNINSULATED CRIMP PIN CONNECTOR.....38		
	PRE-INSULATED PIN CONNECTOR.....38		
	SUPERGRIP PIN CONNECTOR.....38		
	PRE-INSULATED AND SUPERGRIP CRIMP LINK CABLE CONNECTOR.....39		
	CLOSED END PRE-INSULATED CABLE CONNECTOR.....39		
	HEAVY DUTY PRE-INSULATED CRIMP LINK CONNECTOR.....40		
	2.8MM Q.C. RECEPTACLE.....40		
	4.8MM Q.C. RECEPTACLES TO SUIT		
	0.5MM TABS.....40		
	6.3MM Q.C. RECEPTACLES TO SUIT		
	0.8MM TABS.....41		
	6.3MM Q.C. TABS.....41		
	6.3MM ADAPTORS Q.C. PIGGY BACK.....41		
	9.3MM Q.C. RECEPTACLES.....41		
	LIP BLADE TERMINALS.....42		
	BULLET TERMINAL.....42		
	BULLET RECEPTACLE.....42		
	LOOSE PIECE BRASS CONNECTORS.....43		
	TK22 ELECTRICAL TERMINAL KIT.....44		
SECTION 5	OVERHEAD CONDUCTOR SLEEVES AND LUGS.....45		
	NON TENSION SLEEVES.....46		
	FULL TENSION SLEEVES – TYPE A.....46		
	FULL TENSION SLEEVES – TYPE R.....47		
	JUMPER SPLICE SLEEVE.....47		
	TERMINAL LUGS – TYPE AL.....48		
	TERMINAL LUGS – TYPE SL.....48		
	ELECTRICAL JOINTING COMPOUND.....48		
	CONNECTORS FOR STRANDED COPPER CONDUCTORS – IMPERIAL & METRIC.....49		
	#TY SERIES CRIMPING TOOL.....50		
	#TR SERIES CRIMPING TOOL.....50		
	#38A HYDRAULIC CRIMPING TOOL.....50		
SECTION 6	BOLTED OVERHEAD CONNECTORS.....51		
	GENERAL PURPOSE		
	OVERHEAD LINE TAP CONNECTOR.....52		
	DISCONNECT TEE CLAMP.....52		
	SERVICE CONNECTOR.....53		
	LINE STIRRUP CLAMP.....53		
	ELECTRICAL JOINTING COMPOUND.....53		
	PARALLEL GROOVE CONNECTORS.....54		
	BI-METAL PG CLAMPS – DOUBLE & TRIPLE BOLT.....54		
	ALUMINIUM PG CLAMPS – DOUBLE BOLT.....55		
	COPPER PG CLAMPS – SINGLE BOLT.....55		
	COPPER PG CLAMPS – DOUBLE BOLT.....55		
	SPLIT BOLT CONNECTORS.....56		
SECTION 7	TERMINAL BLOCKS.....57		
	STANDARD RANGE RAIL MOUNTED TERMINAL BLOCKS.....58		
	STANDARD RANGE RAIL MOUNTED TERMINAL BLOCKS.....59		
	STUD TYPE RAIL MOUNTED TERMINAL BLOCKS.....60		
	FIXED SCREW TERMINAL BLOCKS & ACCESSORIES.....61		
	QUICK CONNECT TERMINAL BLOCKS.....62		
	TERMINAL CONFIGURATIONS & ORDERING GUIDE.....62		

SECTION 8 APPLICATION TOOLING63

ERGONOMIC DESIGN HAND CRIMP TOOLS ...64

ECONOMY RANGE CRIMP TOOLS66

PROFESSIONAL RANGE CRIMP TOOLS.....68

HEAVY DUTY HAND OPERATED

HYDRAULIC CRIMP TOOLS70

HEAVY DUTY BATTERY OPERATED

HYDRAULIC CRIMP TOOLS72

ACCESSORIES FOR BATTERY

POWERED TOOLS74

HEAVY DUTY HYDRAULIC CRIMPING HEADS .75

HEAVY DUTY HYDRAULIC CRIMPING HEADS .76

HEAVY DUTY HYDRAULIC CRIMPING HEADS .77

HYDRAULIC PUMPS AND CONTROLLERS78

CABLE CUTTERS80

BATTERY OPERATED CABLE CUTTERS81

HYDRAULIC CABLE CUTTERS82

DATA PRODUCTS TOOLS84

CABLE STRIPPERS85

CRIMPING DIES86

12 TONNE DIES87

 HEXAGONAL CRIMP DIES – COPPER .87

 HEXAGONAL CRIMP DIES –

 ALUMINIUM87

 INDENT CRIMP DIES – SECTOR

 ALUMINIUM87

 HEXAGONAL CRIMP DIES – HALF HEX

 (FOR FLEXIBLE CABLES)88

 HEXAGONAL CRIMP DIES –

 C CONNECTORS88

 HEXAGONAL CRIMP DIES – STEEL

 CORES OF ACSR CONDUCTOR88

 HEXAGONAL CRIMP DIES –

 INSULATED ABC CONNECTORS88

DIES FOR 5 TONNE TOOL89

DIES FOR 18 TONNE TOOL89

DIES FOR 40 TONNE TOOL89

DIES FOR 40 TONNE TOOL90

 HEXAGONAL CRIMP DIES - HALF HEX

 (FOR FLEXIBLE CABLES)90

 #TY SERIES CRIMPING TOOL90

 #TR SERIES CRIMPING TOOL90

SECTION 9 CABLE MANAGEMENT AND ASSOCIATED PRODUCTS91

PIN CLIPS H335B SERIES.....92

COPPER EARTH RODS92

EARTH CLIPS92

EARTHING STRAPS.....92

CABLE HOLDERS93

CONDUIT BENDERS94

BATTERY BOOSTER, ALLIGATOR AND

TEST CLIPS95

 BATTERY BOOSTER CLIPS95

 ALLIGATOR CLIPS95

 TEST CLIPS95

 ALLIGATOR AND TEST CLIP

 INSULATORS95

 STAINLESS STEEL BAND CLAMP &

 BUCKLES96

 SHEATHED BAND CLAMP96

#46 BAND CLAMP TOOL.....96

NYLON BAND CLAMP.....97

#117 NYLON BAND FITTING TOOL97

UTI-TIES98

UTI-TIE INSTALLATION TOOL #10199

UTI-TIE INSTALLATION TOOL #TGO9 99

UTI-TIE INSTALLATION TOOL #69.....99

STAINLESS STEEL CABLE TIE

TENSIONER #11691

NYLON HOSE100

SECTION 10 UTILUX EXPRESS REFERENCE

TABLES TOOL SELECTION CHARTS101

UTILUX EXPRESS ORDER FORMS102

CONVERSION TABLES FOR

NON-METRIC CABLE SIZES108

USEFUL REFERENCE TABLES109

COMPRESSION TERMINATION THEORY.....119

BASIC COMPRESSION TERMINATION

PRACTICES119

TERMINATION RECOMMENDATIONS119

FLEXIBLE CABLE CRIMPING120

METRIC DESCRIPTION122

ERGONOMIC DESIGN –123

CATALOGUE INDEX124

FAST FIND INDEX

		Page No.	
Copper	Lugs	bolted	12
		cast	11
		crimp	2-3
		flared entry	5
		long palm, long barrel	11
		narrowpalm	4
		solder	10
		solder sealed	10
		solid palm	14
		stalk	9
	Links	barrier	7
		crimp	6
		reducing	8
	Connectors	bolted Tee clamp	12
		"C"	13
		cable crimp	7
		split bolts	56
		MS sleeves	49
	Crimp dies		86-88
	Tooling		66-85

Aluminium	Lugs	3&4 core sector	16
		CCT cable	18
		crimp	18
		rotating sector	21
		round barrel sector	20
	Links	3&4core sector	19
		crimp	17
		sector to round	19
	Overhead	bolted	14
		full tension sleeves	47-48
		jointing compound	17
		jumper sleeve	47
		non tension sleeves	46
		PG	9
		terminal lug	48
	Crimp dies		86-88
Tooling		66-85	

Bi-metal	Lugs	crimp	24
		3&4 core sector	26
		stalk	28
		3&4 core sector stalk	28
		rotating sector	29
		long palm	30
		reverse	30
		crimp	25
	Links	3&4 core sector	27
		rotating sector	29
	Crimp dies		86-88
	Tooling		66-85

		Page No.	
Tooling	Hand	crimp lugs/links	65-69
		MS sleeves	90
		ergonomic	63-64
		cable tie	99
		band clamp	96-97
		data	84
		terminals	66
		boot lace	66
		crimp	70
	Hydraulic	crimp kit	71
		heads	75-77
		hoses	6
		pumps	78-79
		ABC	72
	Battery	crimp	73
		Versa crimp	72
		accessories	74
	Cutters	hand	80
		hydraulic	83
		battery	81
	Strippers		85
	Dies		86-90

Terminals	Un insulated	ring	32
		fork	35
		high temperature	36
		pin	38
	Pre insulated	ring	33
		ring supergrip	34
		ring heavy duty	37
		fork	36
		fork supergrip	35
		pin	38
		pin supergrip	38
		crimp link	39
		crimp link heavy duty	40
		lip blade	42
		bootlace	37
		closed end	39
		Quick Connect	receptacles
	tabs		41
	open barrel		43
	Blocks	rail mounted	58-60
		fixed screw	61
		quick connect	62
		12 way strip	61

ALPHABETICAL INDEX

	Page		Page		Page
ABC - crimp dies	89	dies - 60 tonne	89 - 90	overhead sleeves	46 - 47
ABC - hydraulic crimp tool	75 & 70	dies - 5 tonne	89	PG clamps	54 - 55
Alligator clips	95	dies - ABC	88 & 90	pin clips	92
Band clamp - stainless steel	96	dies - ACSR steel cores	88 & 90	QC terminal blocks	62
Bandclamp - nylon	97	dies - C connectors	88	QC terminals	40 - 41
Bandclamp tools	96 & 97	dies - holders	86	rail mounted terminal blocks	58 - 60
battery booster clips	95	earth rods	92	reducing links	8
Blocks - Quick Connect	62	earthing accessories	92	reverse bi-metals	30
Blocks - Rail mounted terminals	58 - 60	ergonomic crimp tools	64 - 65	ring terminals	32 - 34
Blocks -screw terminal	61	fixed screw terminal block	61	sector links - aluminium	19
Bolted lugs	12	flared entry copper lugs	5	sector links - bi-metal	27
bootlace ferrules	37	fork terminals	35 - 36	sector links - bi-metal rotating	29
Brass open barrel terminals	43	heavy duty insulated crimp links	40	sector lugs - aluminium	18
C connector	13	heavy duty insulated ring terminals	37	sector lugs - aluminium rotating	21
cable cutters - battery	81	high temperature ring terminals	36	sector lugs - aluminium round barrel	18
cable cutters - hand	80	hose clips - nylon	100	sector lugs - bi-metal	26
cable cutters - hydraulic	83	hydraulic crimp tools	70 - 71, 75 -79	sector lugs - bi-metal rotating	29
cable holders	93	hydraulic cutters	82 - 83	solder lugs	10
cable strippers	85	hydraulic hoses	79	solder sealed lugs	10
cable tie tools	99	hydraulic pumps	78 - 79	solid palm copper lugs	14
cable ties - nylon	98	jointing compound	17	split bolts	56
cable ties - stainless steel	98	long palm bi-metal lugs	30	stalk lugs - bi-metal sector	28
cast copper lugs	11	long palm long barrel copper lugs	11	stalk lugs - copper	9
CCT lugs	20	lugs - aluminium	16	stalk lugs -bi-metal	28
conduit bender	94	lugs - bi-metal	24	terminal kit	44
crimp tools - battery	72 - 73	lugs - copper	2 -3	terminal strip	61
crimp tools - hand	66 - 69	lugs - overhead aluminium	48	test clips	95
crimp tools - hydraulic	70 - 71	MS connectors	49	tooling selection chart	117
data products tools	84	narrow palm copper lugs	4	Utilux Express	102 - 107
dies - 12 tonne	87 - 88	open barrel terminals	43		
dies - 18 tonne	89	overhead lugs	48		



INDEX BY CATALOGUE NO.

Catalogue No.	Page No.	Catalogue No.	Page No.	Catalogue No.	Page No.	Catalogue No.	Page No.	Catalogue No.	Page No.
#00	66	#61	66	38-130ST7	88	40-250ST	90	H1143	43
#101	99	#63	68	38-132AL	87	40-260CU	89	H1145	43
#102	66	#66H	76	38-140AL9	88	40-260ST	90	H1145B	43
#102M	67	#67H	77	38-142CU	87	40-281CU	89	H1191B	43
#102U	67	#69	99	38-165CU	87	40-283AL	89	H1192	43
#108	80	#70H	77	38-173AL	87	40-310CU	89	H1192B	43
#109	80	#76B	66	38-173AL9	88	40-370CU	89	H1365	3
#110	80	#81	84	38-183CU	87	40-390AL	89	H1366	3
#111	70	#88	84	38-200CU	87	40-432AL	89	H1368	3
#111H	75	#89	85	38-210AL	87	40-432CU	89	H1369	3
#111ROBO	72	#98	70	38-215AL9	88	40-480CU	89	H1370	3
#112	67	#98H	75	38-231CU	87	40-95ST	90	H1371	3
#115	96	#98ROBO	73	38-260CU	87	40-95ST19	90	H1381	3
#116	99	#CCS20A	83	38-284AL	87	50A-281CU	89	H1382	3
#117	97	#CCS32	83	38-44CU	87	50A-310CU	89	H1382B	3
#11C	67	#CCS40A	83	38-57CU	87	50A-370CU	89	H1383	3
#120	64	#CCS55	83	38-63CU	87	50A-390AL	89	H1384	3
#121	64	#CCS75	83	38-70CU	87	AC2071/1	94	H1384A	3
#122	64	#CCS85	83	38-74ST13	88	AC2071H/1	94	H1385	3
#124	65	#CCSP100	83	38-76ST	88	AC2071H/1	94	H1386	3
#125	65	#CCSP20A	83	38-77CU	87	AC2081/1	94	H1387	3
#126	65	#CCSP32	83	38-80ST	88	AL36	48	H1387A	3
#12C	67	#CCSP40A	83	38-90AL	87	AL44	48	H1388	3
#12NEST	87	#CCSP55	83	38-92CU	87	AL50	48	H1389	3
#13B	67	#CCSP85	83	38-95ST	88	AL58	48	H1390	3
#140	80	#FC38	79	38-95ST13	88	AL61	48	H1390A	3
#141	80	#HYH2M	79	38-FLAT14	88	AL68	48	H1390B	3
#142	84	#HYH2MNC	79	38-FLAT14	88	AL80	48	H1390C	3
#147A	66	#HYH4M	79	38-FLAT14	88	AL94	48	H1390D	3
#14INDENT	87	#HYH4MNC	79	38-FLAT17	88	BP250R	74	H1391	3
#14NEST	87	#HYH6M	79	38-FLAT17	88	BP70E	74	H1391A	3
#151	85	#HYH6MNC	79	38-FLAT17	88	BP70I	74	H1391B	3
#153	85	#MC38	79	38-FLAT17	88	BT2-1	53	H1394	3
#154	85	#P80	78	38-T020	88	BT2-1PP	53	H1399	2
#15INDENT	87	#PA133	78	38-T026	88	BT2-2	53	H1400	2
#15NEST	87	#PGM2304R	79	38-T044	88	BT2-2PP	53	H1401L	2
#16B	68	#PGM2404R	79	38-T060	88	CBH30-100	93	H1401S	2
#16INDENT	87	#PUJ1200E	78	38-T076	88	CBH30-100V	93	H1402	2
#17	69	#REC-50U	81	38-T098	88	CH3FC	74	H1402A	2
#17INDENT	87	#S20AROBO	81	38-T122	88	CH3FR	74	H1403L	2
#18	68	#S40ROBO	81	38-T154	88	CH-70DC	74	H1403S	2
#18INDENT	87	#TG9	99	38-T190	88	CUP1314WC	92	H1404	2
#19INDENT	87	#TR1588	50	38-T240	88	CUP1318WC	92	H1404A	2
#20	69	#TR794952	50	38-T288	88	FT114A	46	H1404B	2
#20INDENT	87	#TR9521270	50	38-T365	88	FT36A	46	H1405	2
#21	69	#TY476556	50	40-068ST	90	FT36R	47	H1405A	2
#22	69	#TY476635	50	40-130CU	89	FT44A	46	H1405B	2
#28A	69	#TY556635	50	40-140ST19	90	FT44R	47	H1406A	2
#38A	70	#TY635794	50	40-142CU	89	FT50A	46	H1406B	2
#38ROBO	73	#UC6ROBO	72	40-160ST	90	FT50R	47	H1406C	2
#40B	71	111-104115CU	89	40-165CU	89	FT58A	46	H1406L	2
#40BH	76	111-140173AL	89	40-170ST	90	FT58R	47	H1406S	2
#40DH	86	111-142165CU	89	40-172AL	89	FT61A	46	H1407	2
#41A	71	111-215AL	89	40-185CU	89	FT61R	47	H1407A	2
#41AH	75	111-5763CU	89	40-190ST	90	FT68A	46	H1408	2
#42A	71	111-7792CU	89	40-200CU	89	FT68R	47	H1408A	2
#46	96	111-ALSPEC	89	40-200ST19	90	FT80A	46	H1408B	2
#50ADH	86	38-104CU	87	40-220AL	89	FT80R	47	H1409	2
#50AH	76	38-115CU	87	40-231CU	89	FT94A	46	H141	95

INDEX BY CATALOGUE NO.

Catalogue No.	Page No.	Catalogue No.	Page No.	Catalogue No.	Page No.	Catalogue No.	Page No.	Catalogue No.	Page No.
H1410	2	H1496	6	H15215	17	H15415	25	H15713	27
H1411	2	H1499	6	H15216	17	H15416	25	H15714	27
H1411A	2	H15100	16	H15304	24	H15417	25	H15715	27
H1415	2	H15101	16	H15305	24	H15418	25	H15716	27
H1415A	2	H15103	16	H15306	24	H15419	25	H15717	27
H1416	2	H15104	16	H15307	24	H15420	25	H15756	27
H1416A	2	H15106	16	H15308	24	H15421	25	H15757	27
H1416B	2	H15109	16	H15309	24	H15422	25	H15758	27
H1419	3	H15111	16	H15310	24	H15423	25	H15759	27
H1420	3	H15114	16	H15311	24	H15424	25	H15760	27
H1421	3	H15116	16	H15312	24	H15425	25	H15761	27
H1422	3	H15119	16	H15313	24	H15426	25	H15762	27
H1422A	3	H15121	16	H15314	24	H15427	25	H15763	27
H1422B	3	H15124	16	H15315	24	H15428	25	H15764	27
H1423	3	H15126	16	H15316	24	H15429	25	H15765	27
H1423A	3	H15129	16	H15317	24	H15430	25	H15766	27
H1424	3	H15130	16	H15318	24	H15431	25	H15767	27
H1424B	3	H15131	16	H15319	24	H15502	28	H15768	27
H1424C	3	H15134	16	H15320	24	H15503	28	H15769	27
H1425	3	H15135	16	H15321	24	H15504	28	H15816	28
H143	95	H15136	16	H15322	24	H15505	28	H15856	28
H1436	2	H15138	16	H15323	24	H15506	28	H15858	28
H1436A	2	H15139	16	H15324	24	H15507	28	H15860	28
H1437	2	H15141	16	H15325	24	H15508	28	H15862	28
H1437A	2	H15142	16	H15326	24	H15509	28	H15864	28
H1438	3	H15143	16	H15327	24	H15510	28	H15866	28
H1439	3	H15144	16	H15328	24	H15511	28	H15868	28
H144	95	H15146	16	H15329	24	H15512	28	H16011	10
H1440	3	H15147	16	H15330	24	H15513	28	H16012	10
H1442	3	H15148	16	H15331	24	H15514	28	H16014	10
H1443	3	H15151	16	H15332	24	H15515	28	H16015	10
H1445	2	H15153	16	H15333	24	H15516	28	H16016	10
H1448	3	H15154	16	H15334	24	H15517	28	H16018	10
H1448A	3	H15156	16	H15335	24	H15518	28	H16019	10
H1448B	3	H15159	16	H15336	24	H15519	28	H16021	10
H1449	3	H15160	16	H15337	24	H15520	28	H16022	10
H1449A	3	H15161	16	H15353	21	H15521	28	H16023	10
H1449B	3	H15162	16	H15354	21	H15522	28	H16024	10
H145	95	H15165	16	H15355	21	H15610	26	H16026	10
H1451	6	H15166	16	H15356	21	H15611	26	H16027	10
H1452	6	H15171	16	H15357	21	H15612	26	H16029	10
H1453	6	H15172	16	H15358	21	H15613	26	H16030	10
H1454	6	H15174	16	H15362	29	H15614	26	H16032	10
H1455	6	H15176	16	H15363	29	H15615	26	H16033	10
H1456	6	H15200	17	H15364	29	H15616	26	H16035	10
H1458	6	H15201	17	H15365	29	H15617	26	H16036	10
H1460	6	H15202	17	H15366	29	H15618	26	H16038	10
H1461	6	H15203	17	H15367	29	H15619	26	H16039	10
H1462	6	H15204	17	H15404	25	H15660	26	H16041	10
H1467	6	H15205	17	H15405	25	H15661	26	H16042	10
H1470	6	H15206	17	H15406	25	H15664	26	H16044	10
H1471	6	H15207	17	H15407	25	H15665	26	H16045	10
H1474	6	H15208	17	H15408	25	H15666	26	H16047	10
H1475	6	H15209	17	H15409	25	H15667	26	H16048	10
H1488	6	H15210	17	H15410	25	H15668	26	H170	95
H1492	6	H15211	17	H15411	25	H15669	26	H1770	7
H1493	6	H15212	17	H15412	25	H15710	27	H1771	7
H1494	6	H15213	17	H15413	25	H15711	27	H1772	7
H1495	6	H15214	17	H15414	25	H15712	27	H1779	7

INDEX BY CATALOGUE NO.

Catalogue No.	Page No.	Catalogue No.	Page No.	Catalogue No.	Page No.	Catalogue No.	Page No.	Catalogue No.	Page No.
H1781	7	H2049	39	H232	89	H3004	96	H3227	36
H1782	7	H205	10	H2334	9	H3007	96	H3233	36
H1786	7	H2050	39	H2341	9	H3010	96	H3234	36
H1791	7	H2051	40	H2342	9	H3013M-30	96	H335B#1	92
H1792	7	H2052	40	H2345	9	H3016M-30	96	H335B#2	92
H1793	7	H2053	40	H2346	9	H3019M-30	96	H335B#3	92
H1794	7	H2054	40	H2350	9	H3022M-30	96	H335B#4	92
H1795	7	H206	10	H2351	9	H303A#1	92	H335B#5	92
H1796	7	H2067	40	H2354	9	H303A#2	92	H335D#1	92
H1797	7	H2068	39	H2397	17	H303A#3	92	H335D#2	92
H1798	7	H2069	39	H2398	53	H303A#4	92	H335D#3	92
H1799	7	H207	10	H2501EN	61	H3110	32	H335D#4	92
H1801	12	H2070	39	H2501L	61	H3111	32	H349	39
H1802	12	H2071	39	H2501M	61	H3112	32	H3555	43
H1803	12	H2072	39	H2501N	61	H3113	32	H3556	38
H1803A	12	H2073	39	H2502	61	H3114	32	H3558	40
H1804	12	H208	10	H2502E	61	H3115	32	H3559	40
H1804C	12	H2082	95	H2502L	61	H3116	32	H3560	41
H1805	12	H2083BK	95	H2502M	61	H3117	32	H3561	41
H1806	12	H2083RD	95	H2508	61	H3118	32	H3562	41
H1806A	12	H2084	95	H2509	61	H3119	32	H3563	40
H1807	12	H2084BK	95	H2511N	61	H3120	32	H3564	40
H1808	12	H2084RD	95	H2512N	61	H3121	32	H3565	40
H1809	12	H209	10	H2516	61	H3122	32	H3566	40
H1818	12	H2232	58	H2517	61	H3123	32	H3820	60
H1820	12	H2232	59	H2519	61	H3125	32	H3821	60
H1821	12	H2232	60	H2590B	43	H3126	32	H3822	60
H1851	32	H2233	58	H2594	41	H3127	32	H3823	60
H1851B	32	H2233	59	H2594A	41	H3128	32	H3824P	60
H1972	43	H2233	60	H2595	41	H3129	32	H3824P	61
H2001L	37	H2233A	58	H2595A	41	H3130	32	H3863	59
H2001S	37	H2233A	59	H2596	41	H3131	32	H3865	58
H2002	37	H2233A	60	H2596A	41	H3132	32	H3865	60
H2003L	37	H2234A	58	H2608	58	H3133	32	H3910	39
H2003S	37	H2234A	59	H2609	58	H3134	32	H3911	39
H2004	37	H2234A	60	H2631	59	H3137	32	H3912	39
H2005	37	H2236M	59	H2633	58	H3138	32	H3916A	42
H2006	37	H2238	59	H2650	58	H3139	32	H3917A	42
H201	10	H2238V	59	H2736	42	H3140	32	H3918A	42
H202	10	H2239	59	H2736A	42	H3161	32	H3919	42
H2022	7	H2271	38	H2737	42	H3162	32	H3920	42
H2023	39	H2272	38	H2737A	42	H31800	98	H3922	42
H2026	39	H2273	38	H2738A	42	H31801	98	H3923	42
H2027	7	H2276	38	H2743	43	H31802	98	H4107	42
H2029	7	H2278	38	H2782	43	H31803	98	H4107A	42
H203	10	H2280	38	H2790	95	H31804	98	H4108	42
H2033	7	H2286	38	H2796	95	H31806	98	H4108A	42
H2034	7	H2287	38	H2796BK	95	H31820	98	H4109	42
H2035	7	H2288	38	H2796RD	95	H31821	98	H4110	33
H2036	37	H2309	9	H2832	43	H31822	98	H4111	33
H2037	37	H2313	9	H2833B	43	H31823	98	H4112	33
H2038	7	H2314	9	H2844	41	H31824	98	H4113	33
H2039	7	H2317	9	H2845	41	H31826	98	H4114	33
H204	10	H2318	9	H2846	41	H3183	32	H4115	33
H2041	7	H2319	9	H2847A	41	H3185A	32	H4116	33
H2042	7	H2321	9	H2848A	41	H3187A	32	H4117	33
H2043	7	H2325	9	H2849	41	H3215	36	H4118	33
H2047	39	H2326	9	H2853A	41	H3223	36	H4119	33
H2048	39	H2327	9	H3001	96	H3225	36	H4120	33

INDEX BY CATALOGUE NO.

Catalogue No.	Page No.	Catalogue No.	Page No.	Catalogue No.	Page No.	Catalogue No.	Page No.	Catalogue No.	Page No.
H4121	33	H4323	35	JS68R	47	T365	13	WG3915	54
H4122	33	H4326	35	JS80R	47	TB Series	62	WG3932	55
H4123	33	H4331	35	JS94R	47	TCDA19	52		
H4124	33	H4332	35	LS01	53	TDCS1	49		
H4125	33	H4333	35	LS01PP	53	TDCS2	49		
H4126	33	H4334	35	LS01PPSS	53	TDCSM1	49		
H4127	33	H4412	36	LS02	53	TDCSM2	49		
H4128	33	H4414	36	LS02PP	53	TDCSM3	49		
H4129	33	H4415	36	LS02PPSS	53	TECS1	49		
H4130	33	H4417	36	LTGSXXY	52	TECS2	49		
H4131	33	H4421	36	NT114	46	TECSM1	49		
H4132	33	H4423	36	NT36	46	TECSM2	49		
H4133	33	H4425	36	NT44	46	TECSM3	49		
H4134	33	H4426	36	NT50	46	TFCS1	49		
H4137	33	H4431	36	NT58	46	TFCS2	49		
H4138	33	H4432	36	NT61	46	TFCS3	49		
H4139	33	H4433	36	NT68	46	TFCS4	49		
H4140	33	H4434	36	NT80	46	TFCSM1	49		
H4162	33	H4512	35	NT94	46	TFCSM2	49		
H4202	34	H4514	35	PG252	54	TGCS1	49		
H4203	34	H4515	35	PG252PP	54	TGCS2	49		
H4207	42	H4517	35	PG366	54	TGCS3	49		
H4208	42	H4521	35	PG366PP	54	TGCSM1	49		
H4209	42	H4523	35	PG52	54	TGCSM2	49		
H4210	34	H4525	35	PG52PP	54	TGCSM3	49		
H4211	34	H4526	35	PG53	54	THCS1	49		
H4212	34	H4531	35	PG53PP	54	THCS2	49		
H4213	34	H4532	35	PG66	54	THCSM1	49		
H4214	34	H4533	35	PG66PP	54	THCSM2	49		
H4215	34	H4534	35	SB22	56	THCSM3	49		
H4216	34	H50804	18	SB22ET	56	TJCS1	49		
H4217	34	H50805	18	SB24	56	TJCS2	49		
H4218	34	H803A	92	SB24ET	56	TJCSM2	49		
H4219	34	H811	95	SB25	56	TK22	44		
H4220	34	H812	95	SB25ET	56	TKCS1	49		
H4221	34	H82400-20	96	SB26	56	TKCS2	49		
H4222	34	H82401	96	SB26ET	56	TKCS3	49		
H4223	34	H8610	18	SB28	56	TMCS1	49		
H4225	34	H8611	18	SB28ET	56	WG3005	55		
H4226	34	H8613	18	SL36	48	WG3006	55		
H4227	34	H8615	18	SL44	48	WG3007	55		
H4228	34	H8616	18	SL50	48	WG3008	55		
H4229	34	H8627	19	SL58	48	WG3025	55		
H4230	34	H8628	19	SL61	48	WG3026	55		
H4231	34	H8629	19	SL68	48	WG3027	55		
H4232	34	H8630	19	SL80	48	WG3028	55		
H4233	34	H8889	18	T-011	13	WG3029	55		
H4234	34	H8890	18	T-016	13	WG3030	55		
H4237	34	H8891	18	T-020	13	WG3032	55		
H4238	34	H8892	18	T-026	13	WG3587	55		
H4239	34	H8949	19	T-044	13	WG3588	55		
H4240	34	H8950	19	T-060	13	WG3589	55		
H430	43	H8951	19	T-076	13	WG3590	55		
H430B	43	H8952	19	T-098	13	WG3591	55		
H4312	35	JS36R	47	T-122	13	WG3593	55		
H4314	35	JS44R	47	T-154	13	WG3594	55		
H4315	35	JS50R	47	T-190	13	WG3909	54		
H4317	35	JS58R	47	T-240	13	WG3911	54		
H4321	35	JS61R	47	T288	13	WG3913	54		

INDEX BY DESCRIPTIVE NO.

Descriptive No.	Page No.	Descriptive No.	Page No.	Descriptive No.	Page No.	Descriptive No.	Page No.	Descriptive No.	Page No.
AG10M6	16	AGS240M12	18	BG185M16	24	BGRV50MB	30	BKS150/95	27
AG10MB	16	AGS240M16	18	BG185MB	24	BGRV70MB	30	BKS185/120	27
AG120M10	16	AK10	17	BG2	12	BGRV95MB	30	BKS185/185	27
AG120M12	16	AK120	17	BG240LPMB	30	BGS120M12	26	BKS240/150	27
AG120MB	16	AK150	17	BG240M12	24	BGS120MB	26	BKS240/240	27
AG150M10	16	AK16	17	BG240M16	24	BGS150M12	26	BL	39
AG150M12	16	AK185	17	BG240MB	24	BGS150MB	26	BLB	42
AG150M16	16	AK240	17	BG25M10	24	BGS185M12	26	BLBSG	42
AG150MB	16	AK25	17	BG25MB	24	BGS185MB	26	BLBSGW	42
AG16M10	16	AK300	17	BG3	12	BGS240M12	26	BLBW	42
AG16MB	16	AK35	17	BG300LPMB	30	BGS240M16	26	BLD	39
AG185M12	16	AK3I185240	19	BG300M12	24	BGS240MB	26	BLF05	37
AG185M16	16	AK3I240300	19	BG300MB	24	BGS300MB	26	BLF07	37
AG185MB	16	AK400	17	BG35M10	24	BK120/120	25	BLF1	37
AG240M12	16	AK40ET	20	BG35M12	24	BK120/95	25	BLF10	37
AG240M16	16	AK4I240300	19	BG35MB	24	BK150/120	25	BLF120	37
AG240MB	16	AK50	17	BG3A	12	BK150/150	25	BLF16	37
AG25M10	16	AK500	17	BG4	12	BK16/10	25	BLF2	37
AG25MB	16	AK6	17	BG400LPMB	30	BK16/16	25	BLF25	37
AG300M12	16	AK630	17	BG400MB	24	BK185/150	25	BLF3	37
AG300M16	16	AK70	17	BG4C	12	BK185/185	25	BLF35	37
AG300MB	16	AK800	17	BG4HR185M12	29	BK240/185	25	BLF4	37
AG35M10	16	AK95	17	BG4HR185M16	29	BK240/240	25	BLF50	37
AG35MB	16	AKI120	19	BG4HR185MB	29	BK25/16	25	BLF6	37
AG400M12	16	AKI150	19	BG4HR240M12	29	BK25/25	25	BLF70	37
AG400M16	16	AKI185	19	BG4HR240M16	29	BK300/240	25	BLF95	37
AG400MB	16	AKI240	19	BG4HR240MB	29	BK300/300	25	BLFT07	37
AG40M10ET	20	AKS120	19	BG5	12	BK35/25	25	BLFT1	37
AG40M12ET	20	AKS150	19	BG500LPMB	30	BK35/35	25	BLFT2	37
AG4H185M12	18	AKS185	19	BG500MB	24	BK400/300	25	BLFT3	37
AG4H240M12	18	AKS240	19	BG50M10	24	BK400/400	25	BLFT4	37
AG4HR185M12	21	AL36	48	BG50M12	24	BK4HR240150	29	BLFT6	37
AG4HR185M16	21	AL44	48	BG50MB	24	BK50/35	25	BLLBSG	42
AG4HR185MB	21	AL50	48	BG6	12	BK50/50	25	BLLBSGL	42
AG4HR240M12	21	AL58	48	BG630LPMB	30	BK500/400	25	BLSG	39
AG4HR240M16	21	AL61	48	BG630MB	24	BK500/500	25	BP	38
AG4HR240MB	21	AL68	48	BG6A	12	BK630/500	25	BPBSG6.3	41
AG500M12	16	AL80	48	BG7	12	BK630/630	25	BPSG	38
AG500M16	16	AL94	48	BG70M10	24	BK70/50	25	BQCSG4.8	40
AG500MB	16	BBSRG	42	BG70M12	24	BK70/70	25	BQCSG4.8F	40
AG50M10	16	BBSG	42	BG70MB	24	BK95/70	25	BQCSG6.3	41
AG50MB	16	BFM3	36	BG8	12	BK95/95	25	BQCSG6.3F	41
AG630M16	16	BFM4	36	BG800LPMB	30	BKI120/120	27	BQCSG6.3L	41
AG630MB	16	BFM5L	36	BG800MB	24	BKI120/70	27	BRM10	33
AG6M6	16	BFM5S	36	BG9	12	BKI150/150	27	BRM3L	33
AG6MB	16	BFSGM3	35	BG95M10	24	BKI150/95	27	BRM3S	33
AG70M10	16	BFSGM4	35	BG95M12	24	BKI185/120	27	BRM4L	33
AG70M12	16	BFSGM5L	35	BG95MB	24	BKI185/185	27	BRM4M	33
AG70MB	16	BFSGM5S	35	BGI120M12	26	BKI240/150	27	BRM4S	33
AG95M10	16	BG1	12	BGI120MB	26	BKI240/240	27	BRM5L	33
AG95M12	16	BG120M12	24	BGI185M12	26	BKI300/185	27	BRM5S	33
AG95MB	16	BG120M16	24	BGI185MB	26	BKI300/300	27	BRM6	33
AGI120M12	18	BG120MB	24	BGI240M12	26	BKI70/50	27	BRM8	33
AGI150M12	18	BG150M12	24	BGI240MB	26	BKI70/70	27	BRSGM10	34
AGI185M12	18	BG150M16	24	BGI300M16	26	BKI95/70	27	BRSGM3L	34
AGI240M12	18	BG150MB	24	BGI300MB	26	BKI95/95	27	BRSGM3S	34
AGS120M12	18	BG16M10	24	BGRV120MB	30	BKS120/120	27	BRSGM4L	34
AGS150M12	18	BG16MB	24	BGRV25MB	30	BKS120/70	27	BRSGM4S	34
AGS185M12	18	BG185M12	24	BGRV35MB	30	BKS150/150	27	BRSGM5L	34

INDEX BY DESCRIPTIVE NO.

Descriptive No.	Page No.	Descriptive No.	Page No.	Descriptive No.	Page No.	Descriptive No.	Page No.	Descriptive No.	Page No.
BRS GM5S	34	CDC16	87	CG185LPMB	11	CG500MB	3	CK1000	6
BRS GM6	34	CDC185	87	CG185M10	3	CG50FLM10	5	CK120	6
BRS GM8	34	CDC20	87	CG185M12	3	CG50FLM12	5	CK150	6
BS120/12	28	CDC240	87	CG185M16	3	CG50FLM8	5	CK16	6
BS120/14	28	CDC25	87	CG185M20	3	CG50LPMB	11	CK185	6
BS150/12	28	CDC300	87	CG2.5M4	2	CG50M10	3	CK20	6
BS150/14	28	CDC35	87	CG2.5M5	2	CG50M12	3	CK240	6
BS16/12	28	CDC50	87	CG2.5M6	2	CG50M8	3	CK25	6
BS185/16	28	CDC6	87	CG2.5M8	2	CG630LPMB	11	CK300	6
BS185/18	28	CDC70	87	CG20M10	2	CG630MB	3	CK35	6
BS240/16	28	CDC95	87	CG20M12	2	CG6M10	2	CK4	6
BS240/18	28	CEC1	39	CG20M6	2	CG6M6	2	CK400	6
BS25/12	28	CEC1.5	39	CG20M8	2	CG6M8	2	CK50	6
BS300/16	28	CEC2	39	CG240LPMB	11	CG6SDM10	14	CK500	6
BS300/18	28	CEC2.5	39	CG240M10	3	CG6SDM6	14	CK6	6
BS35/12	28	CEC4	39	CG240M12	3	CG6SDM8	14	CK630	6
BS400/18	28	CEC5	39	CG240M16	3	CG70FLM10	5	CK70	6
BS400/20	28	CEC8	39	CG240M20	3	CG70FLM12	5	CK800	6
BS50/12	28	CG0.5M4	2	CG240MB	3	CG70FLM6	5	CK95	6
BS500/18	28	CG0.5M4	2	CG25FLM10	5	CG70FLM8	5	CKB10	7
BS500/20	28	CG0.5SM5	2	CG25FLM12	5	CG70LPMB	11	CKB120	7
BS630/20	28	CG0.5LM5	2	CG25FLM6	5	CG70M10	3	CKB150	7
BS70/12	28	CG0.5M6	2	CG25FLM8	5	CG70M11	3	CKB16	7
BS95/12	28	CG0.5M8	2	CG25LPMB	11	CG70M12	3	CKB185	7
BSI120/12	28	CG1000MB	3	CG25M10	2	CG70M16	3	CKB20	7
BSI150/12	28	CG10LM6	2	CG25M11	2	CG70M20	3	CKB240	7
BSI185/16	28	CG10M10	2	CG25M12	2	CG70M6	3	CKB25	7
BSI240/16	28	CG10M12	2	CG25M6	2	CG70M8	3	CKB300	7
BSI300/16	28	CG10M8	2	CG25M8	2	CG800MB	3	CKB35	7
BSI70/12	28	CG10SDM10	14	CG25SDM10	14	CG95FLM10	5	CKB400	7
BSI95/12	28	CG10SDM6	14	CG25SDM12	14	CG95FLM12	5	CKB50	7
BSS240/16	28	CG10SDM8	14	CG300LPMB	11	CG95FLM6	5	CKB500	7
BT2-1	53	CG10SM6	2	CG300M16	3	CG95FLM8	5	CKB630	7
BT2-1PP	53	CG120FLM10	5	CG300M20	3	CG95LPMB	11	CKB70	7
BT2-2	53	CG120FLM12	5	CG300MB	3	CG95M10	3	CKB95	7
BT2-2PP	53	CG120FLM16	5	CG35FLM10	5	CG95M12	3	CKR120-50	8
BTSG6.3	41	CG120LPMB	11	CG35FLM12	5	CG95M16	3	CKR120-70	8
CC10	13	CG120M10	3	CG35FLM6	5	CG95M20	3	CKR120-95	8
CC120	13	CG120M12	3	CG35FLM8	5	CG95M6	3	CKR150-120	8
CC150	13	CG120M16	3	CG35LPMB	11	CG95M8	3	CKR150-70	8
CC16	13	CG120M20	3	CG35M10	3	CGNP120M10	4	CKR150-95	8
CC185	13	CG150FLM12	5	CG35M11	3	CGNP120M8	4	CKR16-10	8
CC20	13	CG150FLM16	5	CG35M12	3	CGNP150M10	4	CKR16-6	8
CC240	13	CG150LPMB	11	CG35M6	3	CGNP150M8	4	CKR185-120	8
CC25	13	CG150M10	3	CG35M8	3	CGNP185M10	4	CKR185-150	8
CC300	13	CG150M12	3	CG35SDM10	14	CGNP240M10	4	CKR185-95	8
CC35	13	CG150M16	3	CG35SDM12	14	CGNP240M12	4	CKR240-120	8
CC400	13	CG150M20	3	CG400LPMB	11	CGNP300M10	4	CKR240-150	8
CC50	13	CG16M10	2	CG400M16	3	CGNP300M12	4	CKR240-185	8
CC70	13	CG16M11	2	CG400M20	3	CGNP35M6	4	CKR25-10	8
CC95	13	CG16M12	2	CG400MB	3	CGNP50M10	4	CKR25-16	8
CDA150/185	87	CG16M5	2	CG4LM5	2	CGNP50M6	4	CKR25-6	8
CDA240/300	87	CG16M6	2	CG4M10	2	CGNP70M10	4	CKR300-150	8
CDA50/70	87	CG16M8	2	CG4M6	2	CGNP70M6	4	CKR300-185	8
CDA6/35	87	CG16SDM10	14	CG4M8	2	CGNP95M10	4	CKR300-240	8
CDA95/120	87	CG16SDM12	14	CG4SM5	2	CGNP95M8	4	CKR35-10	8
CDC10	87	CG16SDM8	14	CG50LPMB	11	CK0.5	6	CKR35-10	8
CDC120	87	CG185FLM12	5	CG500M16	3	CK02.5	6	CKR35-25	8
CDC150	87	CG185FLM16	5	CG500M20	3	CK10	6	CKR50-16	8

INDEX BY DESCRIPTIVE NO.

Descriptive No.	Page No.	Descriptive No.	Page No.	Descriptive No.	Page No.	Descriptive No.	Page No.	Descriptive No.	Page No.
CKR50-25	8	FT61R	47	PB4	97	RRM1.6	33	SEG95M12	10
CKR50-35	8	FT68A	46	PB7	97	RRM10	33	SG10	10
CKR70-25	8	FT68R	47	PG252	54	RRM3L	33	SG120	10
CKR70-35	8	FT80A	46	PG252PP	54	RRM3M	33	SG150	10
CKR70-50	8	FT80R	47	PG366	54	RRM3S	33	SG16	10
CKR95-35	8	FT94A	46	PG366PP	54	RRM4L	33	SG185	10
CKR95-50	8	HCN10	100	PG52	54	RRM4S	33	SG35	10
CKR95-70	8	HCN12	100	PG52PP	54	RRM5L	33	SG50	10
CS1-120/16	9	HCN13	100	PG53	54	RRM5S	33	SG70	10
CS1-150/16	9	HCN14	100	PG53PP	54	RRM6	33	SG95	10
CS1-185/12	9	HCN15	100	PG66	54	RRM8	33	SL36	48
CS1-185/16	9	HCN17	100	PG66PP	54	RRSGM1.6	34	SL44	48
CS1-35/8	9	HCN19	100	RB10	97	RRSGM10	34	SL50	48
CS1-50/8	9	HCN21	100	RB7	97	RRSGM3L	34	SL58	48
CS1-70/10	9	HCN23	100	RBRSG	42	RRSGM3M	34	SL61	48
CS1-95/10	9	HCN25	100	RBSG	42	RRSGM3S	34	SL68	48
CS2-16/10	9	HCN28	100	RFM3	36	RRSGM4L	34	SL80	48
CS2-16/8	9	HCN30	100	RFM4	36	RRSGM4S	34	TCDA19	52
CS2-25/10	9	HCN32	100	RFM5L	36	RRSGM5L	34	TG185240	12
CS2-25/16	9	HCN35	100	RFM5S	36	RRSGM5S	34	TG5070	12
CS2-35/10	9	HCN38	100	RFSGM3	35	RRSGM6	34	TG7095	12
CS2-35/12	9	HCN7	100	RFSGM4	35	RRSGM8	34	TM19194	98
CS2-35/16	9	HCN8	100	RFSGM5L	35	RTSG6.3	41	TM28284	98
CS2-50/10	9	HCN9	100	RFSGM5S	35	SB22	56	UF1.5M3	35
CS2-50/16	9	JS36R	47	RHD0.5M5L	37	SB22ET	56	UF1.5M4	35
CS2-70/16	9	JS44R	47	RHD0.5M5S	37	SB24	56	UF1.5M5L	35
CS2-95/16	9	JS50R	47	RHD0.5M6	37	SB24ET	56	UF1.5M5S	35
CT1002	98	JS58R	47	RHD10M6	37	SB25	56	F2.5M3	35
CT1002W	98	JS61R	47	RHD2.5M5	37	SB25ET	56	UF2.5M4	35
CT1503	98	JS68R	47	RHD2.5M6	37	SB26	56	UF2.5M5L	35
CT1503W	98	JS80R	47	RHD4M5L	37	SB26ET	56	UF6M3	35
CT2004	98	JS94R	47	RHD4M5S	37	SB28	56	UF6M4	35
CT2004SS	98	LHD10	40	RHD4M6	37	SB28ET	56	UF6M5	35
CT2004W	98	LHD2.5	40	RHD6M6	37	SEG120M10	10	UF6M6	35
CT2008SS	98	LHD2.5S	40	RHT1.5M5	36	SEG120M12	10	UP1.5	38
CT3004	98	LHD4	40	RHT2.5M4	36	SEG150M12	10	UP2.5	38
CT3004W	98	LHD6	40	RHT2.5M5	36	SEG150M16	10	UP6	38
CT3604SS	98	LS01	53	RHT2.5M6	36	SEG185M12	10	UR1.5M1.6	32
CT3608SS	98	LS01PP	53	RHT6M5	36	SEG185M16	10	UR1.5M10	32
CT3704	98	LS01PPSS	53	RHT6M6	36	SEG240M12	10	UR1.5M3L	32
CT3704W	98	LS02	53	RL	39	SEG240MB	10	UR1.5M3M	32
CT3807	98	LS02PP	53	RLB	42	SEG25M10	10	UR1.5M3S	32
CT3807W	98	LS02PPSS	53	RLBSG	42	SEG25M8	10	UR1.5M4L	32
CT5204SS	98	LTGSXXY	52	RLBSGW	42	SEG300M16	10	UR1.5M4S	32
CT55012W	98	MYPSG	38	RLBW	42	SEG300MB	10	UR1.5M5L	32
CT5507W	98	MYRSGM4	34	RLD	39	SEG35M10	10	UR1.5M5S	32
CT6804SS	98	MYRSGM5	34	RLLBSG	42	SEG35M12	10	UR1.5M6	32
CT802	98	NBC10	97	RLLBSGL	42	SEG35M8	10	UR1.5M8	32
CT802W	98	NBC4	97	RLSG	39	SEG400M16	10	UR2.5M10	32
FT114A	46	NBC7	97	RP	38	SEG400MB	10	UR2.5M3L	32
FT36A	46	NT114	46	RPBSG6.3	41	SEG500M20	10	UR2.5M3S	32
FT36R	47	NT36	46	RPSG	38	SEG500MB	10	UR2.5M4L	32
FT44A	46	NT44	46	RQCSG2.8/0.5	40	SEG50M10	10	UR2.5M4S	32
FT44R	47	NT50	46	RQCSG2.8/0.8	40	SEG50M12	10	UR2.5M5L	32
FT50A	46	NT58	46	RQCSG4.8	40	SEG630M20	10	UR2.5M5S	32
FT50R	47	NT61	46	RQCSG4.8F	40	SEG630MB	10	UR2.5M6	32
FT58A	46	NT68	46	RQCSG6.3	41	SEG70M10	10	UR2.5M8	32
FT58R	47	NT80	46	RQCSG6.3F	41	SEG70M12	10	UR20M12	32
FT61A	46	NT94	46	RQCSG6.3L	41	SEG95M10	10	UR20M16	32

INDEX BY DESCRIPTIVE NO.

Descriptive No.	Page No.
UR6M10	32
UR6M12	32
UR6M16	32
UR6M18	32
UR6M3	32
UR6M4L	32
UR6M4S	32
UR6M5	32
UR6M6	32
UR6M8	32
UR8.5M10	32
UR8.5M16	32
UR8.5M6	32
YFM3	36
YFM4	36
YFM5	36
YFM6	36
YFSGM3	35
YFSGM4	35
YFSGM5	35
YFSGM6	35
YL	39
YLBSG	42
YLBSGW	42
YLBW	42
YLD	39
YLLBSG	42
YLSG	39
YP	38
YPBSG6.3	41
YPSG	38
YQC9.3	41
YQCSG6.3	41
YQCSG6.3F	41
YQCSG6.3L	41
YRM10	33
YRM12	33
YRM18	33
YRM3	33
YRM4L	33
YRM4S	33
YRM5	33
YRM6	33
YRM8	33
YRSGM10	34
YRSGM12	34
YRSGM3	34
YRSGM4L	34
YRSGM4S	34
YRSGM5	34
YRSGM6	34
YRSGM8	34
YTSG6.3	41

CONTENTS

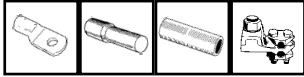

COPPER CONDUCTOR TERMINATIONS

SECTION 1

SECTION 1	COPPER CONDUCTOR TERMINATIONS	1
	COPPER CRIMP LUG	2
	CIRCUIT BREAKER LUGS	4
	COPPER FLARED LUGS	5
	COPPER CRIMP LINKS	6
	COPPER CRIMP LINKS – WITH SOLID BARRIER	7
	REDUCING LINKS	8
	COPPER STALK LUG – TYPE 1	9
	COPPER STALK LUG – TYPE 2	9
	CRIMP CABLE CONNECTOR	9
	CABLE LUG SOLDER TYPE	10
	SEALED COPPER CRIMP LUGS	10
	BOLTED CABLE LUG	11
	BOLTED TEE CLAMP	11
	CAST LUGS	11
	‘C’ CONNECTORS	12
	SOLID PALM COPPER LUGS	13



COPPER CRIMP LUG

- Suitable for copper conductor • Range 0.5-1000 mm²
- Seamless copper tube • Electro tinned
- Cable area clearly identified on the lug
- Tested to AS/NZS 4325.1:1995

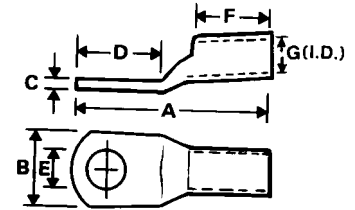

DESCRPT.	CAT NO.	CONDUCTOR AREA (mm ²)	CONDUCTOR STRANDING	STUD SIZE	DIMENSIONS (mm ²)						NO. OF CRIMPS (Tool No.)							CRIMPING DIE
					A	B	C	D	F	G	76	00	18	20	21	22	38A	
CG0.5M4	H1399	0.5	1/0.80	M4	17.5	6.4	1.4	9.5	6.0	2.1	-	-	-	-	-	-	-	
CG0.5M4	H1400			M4	19.1	6.4	1.4	11.1	6.0	2.1	1	1	1	-	-	-	-	-
CG0.5SM5	H1401S			M5	19.1	8.7	1.0	11.1	6.0	2.1	1	1	1	-	-	-	-	-
CG0.5LM5	H1401L			M5	26.6	8.7	1.0	15.1	9.5	2.1	2	2	1	-	-	-	-	-
CG0.5M6	H1402			M6	26.2	10.3	0.9	15.1	9.5	2.1	2	2	1	-	-	-	-	-
CG0.5M8	H1402A			M8	26.2	11.1	0.8	15.1	9.5	2.1	2	2	1	-	-	-	-	-
CG2.5M4	H1436A	2.5	7/0.67	M4	21.4	9.1	1.1	11.9	8.0	2.5	2	1	1	-	-	-	-	
CG2.5M5	H1436			M5	21.4	9.1	1.1	11.9	8.0	2.5	2	1	1	-	-	-	-	-
CG2.5M6	H1437			M6	26.2	10.3	0.9	15.1	8.7	2.5	2	2	1	-	-	-	-	-
CG2.5M8	H1437A			M8	26.2	10.3	0.9	15.1	8.7	2.5	2	2	1	-	-	-	-	-
CG4SM5	H1403S	4	7/0.85	M5	21.0	8.7	1.5	11.1	8.0	3.3	2	1	1	-	-	-	-	
CG4LM5	H1403L			M5	27.3	8.7	1.5	14.7	9.2	3.3	2	2	1	-	-	-	-	-
CG4M6	H1404			M6	27.8	10.3	1.2	15.1	9.5	3.3	2	2	1	-	-	-	-	-
CG4M8	H1404A			M8	28.6	13.0	1.0	13.3	9.5	3.3	2	2	1	-	-	-	-	-
CG4M10	H1404B			M10	28.6	13.0	1.0	16.3	9.5	3.3	2	2	1	-	-	-	-	-
CG6M6	H1405	6	7/1.04	M6	27.0	10.3	1.2	15.0	9.5	3.7	-	2	1	-	1	1	1	
CG6M8	H1405A			M8	28.6	13.9	0.9	16.7	9.5	3.7	-	2	1	-	1	1	1	38-44CU
CG6M10	H1405B			M10	28.6	13.9	0.9	16.7	9.5	3.7	-	2	1	-	1	1	1	
CG10SM6	H1406S	10	7/1.35	M6	27.0	11.9	1.8	15.5	9.5	4.7	-	2	1	-	1	1	1	
CG10LM6	H1406L			M6	29.4	11.9	1.8	15.5	11.5	4.7	-	2	2	-	1	1	1	
CG10M8	H1406A			M8	28.6	14.3	1.6	16.3	9.5	4.7	-	2	1	-	1	1	1	38-57CU
CG10M10	H1406B			M10	30.6	14.3	1.6	16.3	9.5	4.7	-	2	1	-	1	1	1	
CG10M12	H1406C			M12	33.0	17.0	1.4	20.0	11.0	4.7	-	2	1	-	1	1	1	
CG16M5	H1407A	16	7/1.70	M5	39.7	11.6	2.3	16.3	20.6	5.5	-	-	*3	2	2	2	1	
CG16M6	H1407			M6	39.7	11.6	2.3	16.3	20.6	5.5	-	-	*3	2	2	2	1	
CG16M8	H1408			M8	39.7	13.5	1.9	16.3	20.6	5.5	-	-	*3	2	2	2	1	38-63CU
CG16M10	H1408A			M10	41.5	13.5	1.9	18.5	20.6	5.5	-	-	*3	2	2	2	1	
CG16M11	H1445			M11	43.6	16.7	2.8	19.0	22.2	5.5	-	-	-	2	2	2	1	38-77CU
CG16M12	H1408B			M12	46.0	17.5	1.4	20.5	19.0	5.5	-	-	-	2	2	2	1	38-63CU
CG20M6	H1409	20	19/0.44	M6	34.9	12.5	2.3	14.3	19.0	6.3	-	-	-	2	2	2	1	
CG20M8	H1410			M8	42.1	13.5	2.2	19.0	20.3	6.3	-	-	-	2	2	2	1	
CG20M10	H1411			M10	42.1	14.3	2.0	19.0	20.3	6.3	-	-	-	2	2	2	1	38-70CU
CG20M12	H1411A			M11	42.1	15.2	1.9	19.0	20.3	6.3	-	-	-	2	2	2	1	
CG25M6	H1415A	25	19/1.35	M6	43.6	16.7	2.2	19.0	22.0	7.1	-	-	-	2	2	2	1	
CG25M8	H1415			M8	43.6	16.7	2.2	19.0	22.0	7.1	-	-	-	2	2	2	1	
CG25M10	H1416			M10	43.6	16.7	1.9	19.0	22.0	7.1	-	-	-	2	2	2	1	38-77CU
CG25M11	H1416A			M11	43.6	16.7	1.9	19.0	22.0	7.1	-	-	-	2	2	2	1	
CG25M12	H1416B			M12	51.0	18.2	1.7	25.4	21.0	7.1	-	-	-	2	2	2	1	

All sizes of crimp lugs are compatible with imperial size cables except those marked*

DESCRIPT.	CAT NO.	CONDUCTOR AREA (mm ²)	CONDUCTOR STRANDING	STUD SIZE	DIMENSIONS (mm ²)						NO. OF CRIMPS (Tool No.)					CRIMPING DIE
					A	B	C	D	F	G	20	21	22	38A	40B	
CG35M6	H1365	35	19/1.53	M6	43.6	18.2	2.7	19.0	22.2	8.4	2	2	2	1	-	38-92CU
CG35M8	H1366			M8	43.6	18.2	2.7	19.0	22.2	8.4	2	2	2	1	-	
CG35M10	H1368			M10	43.6	18.2	2.7	19.0	22.2	8.4	2	2	2	1	-	
CG35M12	H1369			M12	51.2	20.0	2.4	24.5	22.0	8.4	2	2	2	1	-	
CG35M11	H1442	38	7/0.104	M11	51.6	19.0	3.7	27.0	22.2	8.7	2	2	2	1	-	38-104CU
CG50M8	H1419	50	19/1.78	M8	51.6	18.2	3.1	27.0	22.2	9.5	2	2	2	1	-	38-104CU
CG50M10	H1420			M10	51.6	19.0	3.0	27.0	22.2	9.5	2	2	2	1	-	
CG50M12	H1421			M12	51.6	20.6	2.8	27.0	22.2	9.5	2	2	2	1	-	
CG70M6	H1422B	70	19/2.14	M6	54.0	20.6	3.2	27.0	23.0	11.0	2	-	2	1	-	38-115CU
CG70M8	H1422A			M8	54.0	20.6	3.2	27.0	23.0	11.0	2	-	2	1	-	
CG70M10	H1422			M10	54.0	20.6	3.2	27.0	23.0	11.0	2	-	2	1	-	
CG70M12	H1423			M12	54.0	20.6	3.2	27.0	23.0	11.0	2	-	2	1	-	
CG70M16	H1423A			M16	54.2	27.5	2.4	27.0	22.0	11.0	2	-	2	1	-	
CG70M11	H1443			M11	54.0	22.2	4.7	27.0	23.0	11.2	2	-	2	1	-	
CG70M20	H1439	Is H1438 Sleeved to suit 19/083		M20	76.0	28.6	3.5	45.0	25.4	11.0	-	-	-	1	1	38-142CU
CG95M6	H1424B	95	37/1.78	M6	57.2	25.4	4.0	27.0	27.0	13.4	2	-	2	1	1	38-142CU 40-142CU
CG95M8	H1424C			M8	57.2	25.4	4.0	27.0	27.0	13.4	2	-	2	1	1	
CG95M10	H1424			M10	57.2	25.4	4.0	27.0	27.0	13.4	2	-	2	1	1	
CG95M12	H1425			M12	57.2	25.4	4.0	27.0	27.0	13.4	2	-	2	1	1	
CG95M16	H1440			M16	75.5	27.0	3.7	45.0	25.4	13.4	2	-	2	1	1	
CG95M20	H1438			M20	75.5	28.6	3.5	45.0	25.4	13.4	2	-	2	1	1	
CG120M10	H1381	120	37/2.03	M10	68.3	30.0	4.8	31.8	31.0	15.5	-	-	2	1	1	38-165CU 40-165CU
CG120M12	H1382			M12	68.3	30.0	4.8	31.8	31.0	15.5	-	-	2	1	1	
CG120M16	H1383			M16	68.3	30.0	4.8	31.8	31.0	15.5	-	-	2	1	1	
CG120M20	H1382B			M20	68.3	30.0	4.8	31.8	31.0	15.5	-	-	2	1	1	
CG150M10	H1384A*	150	37/2.25	M10	75.0	33.5	5.4	41.3	27.0	16.3	-	-	-	1	1	38-183CU 40-185CU
CG150M12	H1384*			M12	75.0	33.5	5.4	41.3	27.0	16.3	-	-	-	1	1	
CG150M16	H1385*			M16	75.0	33.5	5.4	41.3	27.0	16.3	-	-	-	1	1	
CG150M20	H1386*			M20	75.0	33.5	5.4	41.3	27.0	16.3	-	-	-	1	1	
CG185M10	H1387A	185	37/2.52	M10	79.0	36.5	5.2	41.3	31.0	18.4	-	-	-	1	1	38-200CU 40-200CU
CG185M12	H1387			M12	79.0	36.5	5.2	41.3	31.0	18.4	-	-	-	1	1	
CG185M16	H1388			M16	79.0	36.5	5.2	41.3	31.0	18.4	-	-	-	1	1	
CG185M20	H1389			M20	79.0	36.5	5.2	41.3	31.0	18.4	-	-	-	1	1	
CG240MB	H1390*	240	61/2.25	MB	127.0	41.6	7.1	54.0	47.6	21.2	-	-	-	3	1	38-231CU 40-231CU
CG240M10	H1390D*			M10	127.0	41.6	7.1	54.0	47.6	21.2	-	-	-	3	1	
CG240M12	H1390A*			M12	127.0	41.6	7.1	54.0	47.6	21.2	-	-	-	3	1	
CG240M16	H1390B*			M16	127.0	41.6	7.1	54.0	47.6	21.2	-	-	-	3	1	
CG240M20	H1390C*			M20	127.0	41.6	7.1	54.0	47.6	21.2	-	-	-	3	1	
CG300MB	H1391	300	61/2.52	MB	127.0	46.0	7.9	54.0	47.6	23.8	-	-	-	3	1	38-260CU 40-260CU
CG300M16	H1391A			M16	127.0	46.0	7.9	54.0	47.6	23.8	-	-	-	3	1	
CG300M20	H1391B			M20	127.0	46.0	7.9	54.0	47.6	23.8	-	-	-	3	1	
CG400MB	H1448	400	61/2.85	MB	123.0	49.6	7.9	54.0	41.3	26.9	-	-	-	-	1	40-281CU 50-281CU 66-281CU
CG400M16	H1448A			M16	123.0	49.6	7.9	54.0	41.3	26.9	-	-	-	-	1	
CG400M20	H1448B			M20	123.0	49.6	7.9	54.0	41.3	26.9	-	-	-	-	1	
CG500MB	H1449	500	61/3.20	MB	142.5	54.8	8.2	54.0	55.5	30.0	-	-	-	-	2	40-310CU 50-310CU 66-310CU
CG500M16	H1449A			M16	142.5	54.8	8.2	54.0	55.5	30.0	-	-	-	-	2	
CG500M20	H1449B			M20	142.5	54.8	8.2	54.0	55.5	30.0	-	-	-	-	2	
CG630MB	H1394*	630	127/2.52	MB	146.0	63.5	11.5	54.0	58.0	33.5	-	-	-	-	2	40-370CU 50-370CU
CG800MB	H1370	800	127/2.85	MB	275.0	75.0	14.0	127.0	105.0	39.3	-	-	-	-	3	40-432CU
CG1000MB	H1371	1000	127/3.20	MB	295.0	85.0	16.0	125.0	110.0	44.0	-	-	-	-	3	40-480CU



NARROW PALM

- Specially made for terminating large cables to circuit breakers
- Unique bell mouth for easy insertion of fine stranded conductors
- Made for 99.9%+ high conductivity copper

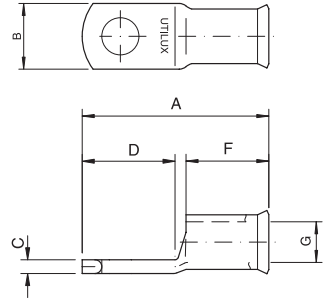

CAT NO.	NOMINAL CONDUCTOR mm ²	BOLT SIZE	DIMENSIONS mm						NO. OF CRIMPS (Tool NO.)					CRIMPING DIE
			A	B	C	D	F	G	20	21	22	38A	40B	
CGNP35M6	35	M6	44	15	2.7	15	21	8.4	2	2	2	1	-	38-92CU
CGNP50M6	50	M6	52	15	3.0	15	22	9.5	2	2	2	1	-	38-104CU
CGNP50M10	50	M10	52	19	3.0	21	22	9.5	2	2	2	1	-	38-104CU
CGNP70M6	70	M6	54	17	3.2	15	24	11.0	2	-	2	1	-	38-115CU
CGNP70M10	70	M10	54	19	3.2	21	24	11.0	2	-	2	1	-	38-115CU
CGNP95M8	95	M8	57	19	4	17	27	13.4	2	-	2	1	-	38-142CU
CGNP95M10	95	M10	57	19	4	21	27	13.4	2	-	2	1	-	38-142CU
CGNP120M8	120	M8	68	19	4.8	23	30	15.5	-	-	2	1	1	38-165CU
CGNP120M10	120	M10	68	19	4.8	23	30	15.5	-	-	2	1	1	38-165CU
CGNP150M8	150	M8	75	19	5.4	27	30	16.3	-	-	-	1	1	38-183CU
CGNP150M10	150	M10	75	19	5.4	27	30	16.3	-	-	-	1	1	38-183CU
CGNP185M10	185	M10	79	31	5.2	32	32	18.4	-	-	-	1	1	38-200CU
CGNP240M10	240	M10	127	31	7.1	32	38	21.2	-	-	-	3	1	38-231CU
CGNP240M12	240	M12	127	31	7.1	32	38	21.2	-	-	-	3	1	38-231CU
CGNP300M10	300	M10	127	31	7.9	32	42	23.8	-	-	-	3	1	38-260CU
CGNP300M12	300	M12	127	31	7.9	32	42	23.8	-	-	-	3	1	38-260CU

COPPER FLARED LUGS

The range of flared copper lugs has been designed with the barrel entry flared to enable an easy insertion of multi stranded cables (flexible cable). The range of connectors (from 25mm² to 185mm²) will ensure most applications for the common flexible cable sizes are covered. The flared copper lugs are made from seamless copper tube, electro tin plated and have the cable area clearly marked on the palm of the lug. The inspection window on the barrel provides a check that the cable has been fully inserted. The flared lugs can be crimped with the standard range of Utilux tooling and hexagonal dies.

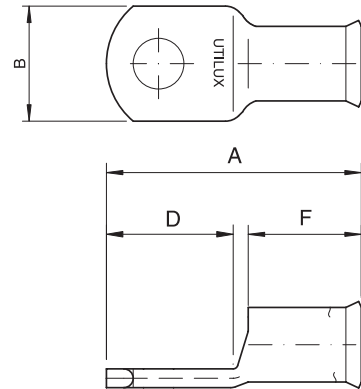

CAT NO.	CONDUCTOR SIZE (mm ²)	STRANDING METRIC	BOLT SIZE	DIMENSIONS (mm)				NO. OF CRIMPS (Tool No.)					CRIMPING DIE
				A	B	D	F	20	21	22	38A	40B	
CG25FLM6	25	209/0.40	M6	44	17	19	22	2	2	2	1	-	38-77CU
CG25FLM8		209/0.40	M8	44	17	19	22	2	2	2	1	-	
CG25FLM10		209/0.40	M10	44	17	19	22	2	2	2	1	-	
CG25FLM12		209/0.40	M12	44	17	19	22	2	2	2	1	-	
CG35FLM6	35	285/0.40	M6	44	18	19	22	2	2	2	1	-	38-92CU
CG35FLM8		285/0.40	M8	44	18	19	22	2	2	2	1	-	
CG35FLM10		285/0.40	M10	44	18	19	22	2	2	2	1	-	
CG35FLM12		285/0.40	M12	44	18	19	22	2	2	2	1	-	
CG50FLM8	50	380/0.40	M8	52	21	27	22	2	2	2	1	-	38-104CU
CG50FLM10		380/0.40	M10	52	21	27	22	2	2	2	1	-	
CG50FLM12		380/0.40	M12	52	21	27	22	2	2	2	1	-	
CG70FLM6	70	203/0.67	M6	54	21	27	23	2	-	2	1	-	38-115CU
CG70FLM8		203/0.67	M8	54	21	27	23	2	-	2	1	-	
CG70FLM10		203/0.67	M10	54	21	27	23	2	-	2	1	-	
CG70FLM12		203/0.67	M12	54	21	27	23	2	-	2	1	-	
CG95FLM6	95	259/0.67	M6	57	25	27	27	2	-	2	1	-	38-142CU
CG95FLM8		259/0.67	M8	57	25	27	27	2	-	2	1	-	
CG95FLM10		259/0.67	M10	57	25	27	27	2	-	2	1	-	
CG95FLM12		259/0.67	M12	57	25	27	27	2	-	2	1	-	
CG120FLM10	120	336/0.67	M10	68	30	32	31	-	-	2	1	1	38-165CU
CG120FLM12		336/0.67	M12	68	30	32	31	-	-	2	1	1	
CG120FLM16		336/0.67	M16	68	30	32	31	-	-	2	1	1	
CG150FLM12	150	427/0.67	M12	75	34	32	27	-	-	-	1	1	38-183CU
CG150FLM16		427/0.67	M16	75	34	32	27	-	-	-	1	1	
CG185FLM12	185	518/0.67	M12	79	34	32	31	-	-	-	1	1	38-200CU
CG185FLM16		518/0.67	M16	79	34	32	31	-	-	-	1	1	



COPPER CRIMP LINKS

- Solid drawn copper tube
- Centre dimples • Ends reamed

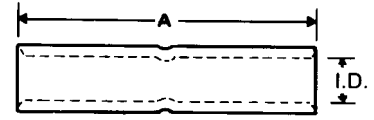

DESCRIPT.	CAT NO.	CONDUCTOR AREA mm ²	STRANDING METRIC	DIMENSIONS mm		NO. OF CRIMPS (TOOL NO.)							CRIMPING DIE		
				A	I.D.	00	18	20	21	22	38A	40B			
CK0.5	H1451	0.5	1/0.80	22	2.1	2	-	-	-	-	-	-	-	-	-
CK02.5	H1467	2.5	7/0.67	22	2.5	2	-	-	-	-	-	-	-	-	-
CK4	H1452	4	7/0.85	22	3.3	2	1	-	-	-	-	-	-	-	-
CK6	H1453	6	7/1.04	22	3.7	2	1	-	2	2	1	-	-	38-44CU	-
CK10	H1454	10	7/1.35	22	4.7	2	1	-	2	2	1	-	-	38-57CU	-
CK16	H1455	16	7/1.70	44	5.5	-	3	2	2	2	1	-	-	38-63CU	-
CK20	H1456	20	19/0.44	44	6.3	-	-	2	2	2	1	-	-	38-70CU	-
CK25	H1458	25	19/1.35	48	7.1	-	-	2	2	2	1	-	-	38-77CU	-
CK35	H1488	35	19/1.53	48	8.4	-	-	2	2	2	1	-	-	38-92CU	-
CK50	H1460	50	19/1.78	48	9.5	-	-	2	2	2	1	-	-	38-104CU	-
CK70	H1461	70	19/2.14	51	11.0	-	-	2	-	2	1	-	-	38-115CU	-
CK95	H1462	95	37/1.78	54	13.4	-	-	2	-	2	1	1	-	38-142CU	-
CK120	H1492	120	37/2.03	65	15.5	-	-	-	-	2	1	1	-	38-165CU	-
CK150	H1493*	150	37/2.25	65	16.3	-	-	-	-	-	2	1	-	38-183CU	-
CK185	H1494	185	37/2.52	65	18.4	-	-	-	-	-	2	1	-	38-200CU	-
CK240	H1495	240	61/2.25	89	21.2	-	-	-	-	-	3	1	-	38-231CU	-
CK300	H1496	300	61.2.52	89	23.8	-	-	-	-	-	3	1	-	38-260CU	-
CK400	H1470	400	61/2.85	89	26.8	-	-	-	-	-	-	-	1	40-281CU	-
CK500	H1471	500	61/3.20	114	30.0	-	-	-	-	-	-	-	1	40-310CU	-
CK630	H1499*	630	127/2.52	114	33.5	-	-	-	-	-	-	-	2	40-370CU	-
CK800	H1474	800	127/2.85	230	39.3	-	-	-	-	-	-	-	3	40-432CU	-
CK1000	H1475	1000	127/3.20	230	43.8	-	-	-	-	-	-	-	3	40-480CU	-

All sizes of crimp links are compatible with imperial size cables except those marked*





COPPER CRIMP LINKS – WITH SOLID BARRIER

- For use with oil filled cables
- Solid drawn copper rod
- Electro tinned
- Solid centre barriers
- Ends reamed

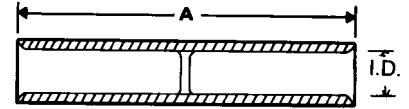

DESCRIPT.	CAT NO.	CONDUCTOR AREA mm ²	STRANDING METRIC	DIMENSIONS		NO. OF CRIMPS (Tool No.)					CRIMPING DIE
				A	I.D.	20	21	22	38A	40B	
CKB10	H1782	10	7/1.35	48	4.7	-	2	2	1	-	38-57CU
CKB16	H1781	16	7/1.70	44	5.5	2	2	2	1	-	38-63CU
CKB20	H1786	20	7/2.14	44	6.7	2	2	2	1	-	38-74CU
CKB25	H1779	25	19/1.35	48	7.1	2	2	2	1	-	38-77CU
CKB35	H1791	35	19/1.53	48	8.4	2	2	2	1	-	38-92CU
CKB50	H1770	50	19/1.78	54	9.5	2	2	2	1	-	38-104CU
CKB70	H1771	70	19/2.14	51	11.0	2	-	2	1	-	38-115CU
CKB95	H1772	95	37/1.78	54	13.4	2	-	2	1	1	38-142CU
CKB120	H1792	120	37/2.03	65	15.5	-	-	2	1	1	38-165CU
CKB150	H1793	150	37/2.25	65	16.3	-	-	-	2	1	38-183CU
CKB185	H1794	185	37/2.52	65	18.4	-	-	-	2	1	38-200CU
CKB240	H1795	240	61/2.25	76	21.2	-	-	-	3	1	38-231CU
CKB300	H1796	300	61/2.52	76	23.8	-	-	-	3	1	38-260CU
CKB400	H1797	400	61/2.85	89	26.8	-	-	-	-	1	40-281CU
CKB500	H1798	500	61/3.20	114	30.0	-	-	-	-	1	40-310CU
CKB630	H1799	630	127/2.52	145	33.5	-	-	-	-	2	40-370CU

1

CRIMP CABLE CONNECTOR

- Seamless drawn Copper tube
- Electro tinned

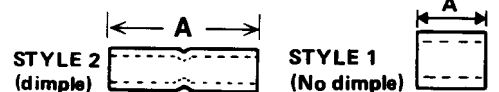

CAT NO.	SIZE	DIMENSIONS mm A	STYLE	TOOL NO.
H2038	1	7.9	1	00, 16B, 76B
H2033	1	15.1	2	00, 16B, 76B
H2039	2	7.9	1	00, 16B, 76B, 18A
H2034	2	15.1	2	00, 16B, 76B, 18A
H2035	3	14.3	2	00, 16B, 76B, 18A
H2042	2 x 24/0.20	6.4	1	00, 16B, 76B
H2022	2 x 50/0.25	8.5	1	00, 16B, 18A
H2027	3 x 32/0.20	9.5	1	00, 16B, 18, 76B
H2043	3 x 32/0.20	7.9	1	00, 16B, 18, 76B
H2029	5 x 32/0.20	9.5	1	00, 16B, 18A
H2041	2 x 50/0.25	11.1	1	20, 38A, 21, 22



REDUCING LINKS

- Solid drawn copper rod
- Electro tin plated
- Stock sizes shown
- Custom sizes to order
- Crimp with standard Utilux hex dies

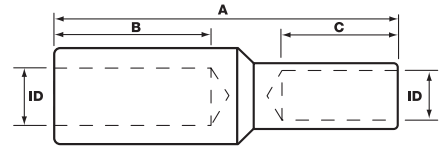

DESCRPT.	CONDUCTOR AREA mm ²	LARGE END			CRIMPING DIE	SMALL END		CRIMPING DIE
		A	B	ID		C	ID	
CKR16-6	16-6	55	27	5.5	38-63CU	28	3.7	38-44CU
CKR16-10	16-10	55	27	5.5		28	4.5	38-57CU
CKR25-6	25-6	56	27	7.2	38-77CU	29	3.7	38-44CU
CKR25-10	25-10	56	27	7.2		29	4.5	38-57CU
CKR25-16	25-16	56	28	7.2		29	5.5	38-63CU
CKR35-10	35-10	56	27	8.5	38-92CU	29	4.5	38-57CU
CKR35-16	35-16	56	28	8.5		29	5.5	38-63CU
CKR35-25	35-25	56	28	8.5		28	7.2	38-77CU
CKR50-16	50-16	58	28	9.5	38-104CU	30	5.5	38-63CU
CKR50-25	50-25	58	28	9.5		30	7.2	38-77CU
CKR50-35	50-35	58	29	9.5		30	8	38-92CU
CKR70-25	70-25	58	28	11.0	38-115CU	30	7.2	38-77CU
CKR70-35	70-35	58	29	11.0		30	8.5	38-92CU
CKR70-50	70-50	58	29	11.0		30	9.5	38-104CU
CKR95-35	95-35	75	29	13.5	38-142CU	46	8.5	38-92CU
CKR95-50	95-50	75	29	13.5		46	9.5	38-104CU
CKR95-70	95-70	75	30	13.5		46	11.0	38-115CU
CKR120-50	120-50	75	29	15	38-165CU	46	9.5	38-104CU
CKR120-70	120-70	75	30	15		46	11.0	38-115CU
CKR120-95	120-95	88	44	15		44	13.5	38-142CU
CKR150-70	150-70	77	30	16.5	38-183CU	48	11.0	38-115CU
CKR150-95	150-95	90	44	16.5		46	13.5	38-142CU
CKR150-120	150-120	90	44	16.5		46	15	38-165CU
CKR185-95	185-95	90	44	18.5	38-200CU	46	13.5	38-142CU
CKR185-120	185-120	90	44	18.5		46	15	38-165CU
CKR185-150	185-150	90	45	18.5		45	16.5	38-183CU
CKR240-120	240-120	98	44	21.5	38-231CU 40-231CU	54	15	38-165CU
CKR240-150	240-150	98	45	21.5		53	16.5	38-183CU
CKR240-185	240-185	98	45	21.5		53	18.5	38-200CU
CKR300-150	300-150	98	45	24	38-260CU 40-260CU	53	16.5	38-183CU
CKR300-185	300-185	98	45	24		53	18.5	38-200CU
CKR300-240	300-240	101	50	24		51	21.5	38-231CU

Any size can be made for items not shown above – complete Utilux Express form on page 103 and fax to our manufacturing site on (02) 4353 2470



COPPER STALK LUG - TYPE 1

- Electro tinned finish
- Alternative sizes made to order

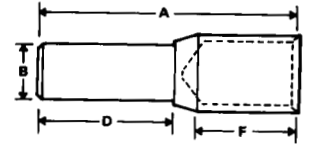

DESCRPT.	CAT NO.	CONDUCTOR AREA mm ²	STRANDING METRIC	DIMENSIONS (mm)				CRIMPING DIE
				A	B	D	F	
CS1-35/8	H2309	35	19/1.53	70	8	34	25	38-92CU
CS1-50/8	H2313	50	19/1.78	70	8	34	25	38-104CU
CS1-70/10	H2317	70	19/2.14	70	10	34	25	38-115CU
CS1-95/10	H2331	95	37/1.78	70	10	34	25	38-142CU
CS1-120/16	H2314	120	37/2.03	73	16	38	25	38-165CU
CS1-150/16	H2318	150	37/2.25	73	16	38	25	38-183CU
CS1-185/12	H2319	185	37/2.52	73	12	38	25	38/40-200CU
CS1-185/16	H2321	185	37/2.52	73	16	38	25	38/40-200CU

Note: Conductor areas indicated for STYLE 1 are combined areas of wire to be spliced



COPPER STALK LUG - TYPE 2

- Electro tinned finish
- Alternative sizes made to order

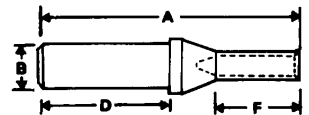

DESCRPT.	CAT NO.	CONDUCTOR AREA mm ²	STRANDING METRIC	DIMENSIONS mm				CRIMPING DIE
				A	B	D	F	
CS2-16/8	H2341	16	7/1.70	52	8	22	22	38-63CU
CS2-16/10	H2342		7/1.70	67	10	34	22	
CS2-25/10	H2345	25	19/1.35	67	10	34	22	38-77CU
CS2-25/16	H2346		19/1.35	70	16	38	22	
CS2-35/10	H2325		19/1.53	70	10	34	22	
CS2-35/12	H2326	35	19/1.53	70	12	34	22	38-92CU
CS2-35/16	H2327		19/1.53	70	16	34	22	
CS2-50/10	H2350	50	19/1.78	70	10	34	22	38-104CU
CS2-50/16	H2351		19/1.78	73	16	38	22	
CS2-70/16	H2328	70	19/2.14	73	16	38	22	38-115CU
CS2-95/16	H2354	95	37/1.78	70	16	34	22	38-142CU

1



CABLE LUG SOLDER TYPE

- Solid drawn copper tube • Electro tinned • Alternative sizes made to order
- Not recommended for crimping • Bright acid tin finish for easy solderability

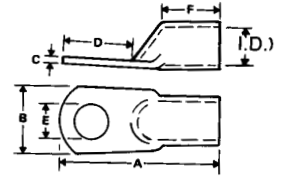

DESCRPT.	CAT NO.	MAX AREA mm ²	NOMINAL AMPS FOR CU CABLE	STUD SIZE E	DIMENSIONS mm					
					A	B	C	D	F	I.D.
SG10	H201	10	75	M5	28.6	8.9	1.8	8.9	9.5	4.5
SG16	H202	16	99	M6	38.6	11.9	1.6	16.0	17.0	6.1
SG35	H203	25-35	155	M8	38.1	16.0	1.8	16.5	12.7	9.3
SG50	H204	50	250	M10	44.5	18.5	2.4	20.5	15.9	10.3
SG70	H205	70	310	M10	56.0	23.1	3.3	27.5	17.9	12.6
SG95	H206	95	375	M12	68.0	28.0	3.3	33.5	20.6	15.8
SG120	H207	120	435	M16	79.5	33.0	3.3	36.0	22.2	19.0
SG150	H208	150	570	M20	85.7	37.6	4.0	36.0	28.6	21.3
SG185	H209	185-240	680	M20	106.5	46.5	5.3	48.0	37.0	26.5



SEALED COPPER CRIMP LUGS

- Long barrel length for effective heat shrink sealing
- Designed for outdoor terminations
- Solder sealed • Impervious to air at 140 kPa min

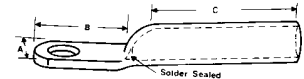

DESCRPT.	CAT NO.	CONDUCTOR AREA mm ²	STRANDING METRIC	STUD SIZE	DIMENSIONS (mm)			CRIMPING DIE
					A	B	C	
SEG25M8	H16011	25	7/2.14-19/1.35	M8	14.7	19	29	38-77CU
SEG25M10	H16012			M10	16.7	19	29	
SEG35M8	H16014	35	19/1.53	M8	18.2	19	35	38-92CU
SEG35M10	H16015			M10	18.2	19	35	
SEG35M12	H16016			M12	20.0	24.5	35	
SEG50M10	H16018	50	19/1.78	M10	19.0	27	38	38-104CU
SEG50M12	H16019			M12	20.6	27	38	
SEG70M10	H16021	70	19/2.14	M10	20.6	27	43	38-115CU
SEG70M12	H16022			M12	20.6	27	43	
SEG95M10	H16023	95	19/2.52	M10	25.4	27	53	38-142CU
SEG95M12	H16024			M12	25.4	27	53	
SEG120M10	H16026	120	37/2.03	M10	30.0	31.8	62	38/40-165CU
SEG120M12	H16027			M12	30.0	31.8	62	
SEG150M12	H16029	150	37/2.25	M12	33.5	41.3	67	3/40-183CU
SEG150M16	H16030			M16	33.5	41.3	67	
SEG185M12	H16032	185	37/2.52	M12	36.5	41.3	77	38/40-200CU
SEG185M16	H16033			M16	36.5	41.3	77	
SEG240MB	H16035	240	61/2.25	MB	41.6	54	86	38/40-231CU
SEG240M12	H16036			M12	41.6	54	86	
SEG300MB	H16038	300	61/2.52	MB	46.0	54	95	38/40-260CU
SEG300M16	H16039			M16	46.0	54	95	
SEG400MB	H16041	400	61/2.85	MB	49.6	54	105	40/66-281CU
SEG400M16	H16042			M16	49.6	54	105	
SEG500MB	H16044	500	61/3.20	MB	54.8	54	115	40/66-310CU
SEG500M20	H16045			M20	54.8	54	115	
SEG630MB	H16047	630	127/2.52	MB	63.5	54	133	40-370
SEG630M20	H16048			M20	63.5	54	133	

LONG PALM LONG BARREL COPPER CRIMP LUGS

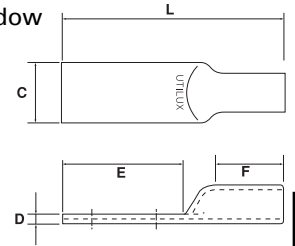

- Long barrel length for effective heat shrink sealing • No inspection window
- Uses same crimp tools as standard copper lugs

1

DESCRIPT. P/N	CONDUCTOR AREA mm ²	DIMENSIONS mm					CRIMPING DIE
		C	D	E	F	L	
CG16LPMB	16	13	1.9	70	40	114	38-63CU
CG25LPMB	25	17	1.9	70	40	115	38-77CU
CG35LPMB	35	18	2.7	90	45	140	38-92CU
CG50LPMB	50	21	2.8	100	50	160	38-104CU
CG70LPMB	70	21	3.2	100	50	160	38-115CU
CG95LPMB	95	25	4.0	100	50	160	38-142CU
CG120LPMB	120	30	4.8	100	50	160	38-165CU
CG150LPMB	150	34	5.4	100	50	170	38-183CU
CG185LPMB	185	37	5.4	100	55	170	38-200CU
CG240LPMB	240	42	7.1	110	60	190	38-231CU
CG300LPMB	300	46	7.9	110	60	190	40-260CU
CG400LPMB	400	50	7.9	110	70	210	40-281CU
CG500LPMB	500	55	8.2	110	70	210	40-310CU
CG630LPMB	630	64	11.5	100	70	205	40-370CU

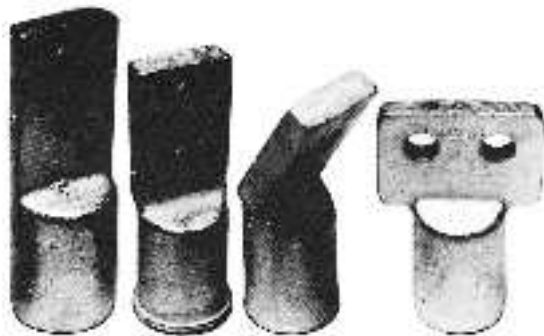

CAST LUGS

- Made to custom requirements
- Made to approved order, quantities only
- Copper alloy, however can be made in other materials
- Type of applications; – diesel electric loco
– transformers – special application



BOLTED CABLE LUG

- Quick and easy termination • Re-usable
- Palms are machined flat and parallel for maximum conductivity
- Copper alloy

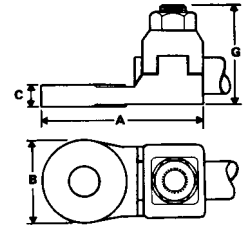

DESCRIPT.	CAT NO.	GENERIC CODE	CONDUCTOR AREA mm ²	NON FLEXIBLE CONDUCTOR	STUD SIZE	DIMENSIONS mm			
						A	B	C	D
BG1	H1801	NO. 1	4-10	7/0.85 7/1.04 7/1.35	M6	34	14	5.5	17
BG2	H1802	NO. 2	16	7/1.70	M8	44	19	5.5	23
BG3 BG3A	H1803 H1803A	NO. 3	25-35	7/2.14 19/1.53	M10 M12	53	25	5.5	27
BG4	H1804	NO. 4	50-70	19/1.78 19/2.14	M12	60	32	6.4	34
BG4C*	H1804C	NO. 4C	50-70	19/1.78 19/2.14	M12	60	32	6.4	34
BG5	H1805	NO. 5	95	37/1.78	M12	65	32	7.9	38
BG6A	H1806A	NO. 6	120	37/2.03	M16	76	38	8.7	45
BG6	H1806	NO. 6	150-185	37/2.25 37/2.52	M16	76	38	8.7	45
BG7	H1807	NO. 7	185-240	61/2.25	M20	86	44	10.3	53
BG8	H1808	NO. 8	300-400	61/2.52 61/2.85	M20	98	51	12.7	63
BG9	H1809	NO. 9	500	61/3.20	M20	100	48	13.5	70

*C = Slot 12mm wide instead of bolt hole



BOLTED TEE CLAMP

- Provide quick and easy tee offs
- Copper alloy
- H1820 and H1821 can be used with slotted palm lugs for easy disconnect facility

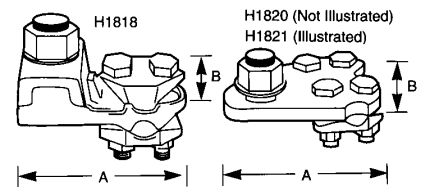

DESCRIPT.	CAT NO.	MAIN CABLE RANGE		TEE CABLE RANGE		DIMENSIONS	
		MIN	MAX	MIN	MAX	A	B
TG185240	H1818	185mm ²	240mm ²	70mm ²	95mm ²	81	33
TG5070	H1820	50mm ²	70mm ²	-	-	79	32
TG7095	H1821	70mm ²	95mm ²	-	-	87	70

'C' CONNECTORS



C-Connectors are manufactured in 'C' shaped copper section for connection of main and tap copper conductors.

- Reliability is ensured by passing tests specified by JIS C 2810
- Suitable for connecting copper conductors in both indoor and outdoor applications such as earth grid connections
- Tin plated • Other sizes available on request (366-700mm²)

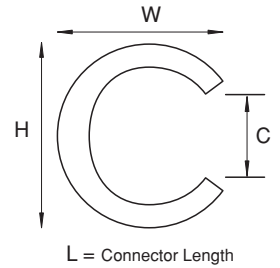
1

DESCRPT.	CAT NO.	CONDUCTOR RANGE mm ²	DIMENSIONS				Die Part No.	INSULATING COVER
			H	W	L	C		
CC10	T-011	7.5 to 11	9	6	12	4	#18C	-
CC16	T-016	11.5 to 16	12	8	13	5	#18C	-
CC20	T-020	14 to 20	13	10	13	5	38-T020	T-020C
CC25	T-026	21 to 26	15	11	16	6	38-T026	T-026C
CC35	T-044	27 to 44	19	14	20	8	38-T044	T-044C
CC50	T-060	45 to 60	21	15	22	10	38-T060	T-060C
CC70	T-076	61 to 76	24	17	22	11	38-T076	T-076C
CC95	T-098	77 to 98	28	19	25	14	38-T098	T-098C
CC120	T-122	99 to 122	30	21	26	13	38-T122	T-122C
CC150	T-154	123 to 154	34	24	28	17	38-T154	T-154C
CC185	T-190	155 to 190	37	25	35	17	38-T190	T-190C
CC240	T-240	191 to 240	40	28	40	19	38-T240	T-240C
CC300	T-288	241 to 288	45	31	45	22	38-T288	T-288C
CC400	T-365	289 to 365	48	34	50	24	38-T365	T-365C

		CONDUCTOR TAP mm ²																	
		2.5	4	6	10	16	20	25	35	50	70	95	120	150	185	240	300	400	
MAIN CONDUCTOR mm ²	6	11	11	16															
	10	16	16	16															
	16	20	20	26	26	44													
	20	26	26	26	44	44	44												
	25	44	44	44	44	44	60	60											
	35	44	44	44	60	60	60	60	76										
	50	60	60	60	60	76	76	76	98	122									
	70	76	76	76	98	98	98	98	122	122	154								
	95	98	122	122	122	122	122	122	154	154	190	190							
	120	154	154	154	154	154	154	154	190	190	190	240	240						
	150	154	154	190	190	190	190	190	190	240	240	288	288	365					
	185	190	190	240	240	240	240	240	240	240	288	288	365	365	450				
	240			288	288	288	288	288	288	365	365	365	365	450	450	560			
300			365	365	365	365	365	365	365	450	450	450	450	560	560	700			
400								450	450	560	560	560	560	700	700	700			
500								560	560	700	700	700	700	700					
630								700	700	700									

SOLID PALM COPPER LUGS



Utilux have introduced a range of small copper lugs to be used in heavy industry. The range of connectors (6sqmm to 35sqmm) compliments the existing larger size copper cast lugs. The lugs are fabricated from copper rod to maximise the strength. They are made without a seam in the palm, with an increased wall thickness and electro-tinned plated. The solid palm also eliminates the ingress of moisture which makes them suitable for outdoor use. Crimping has been rationalised so that only two (2) sets of dies are required to terminate the full range of lugs.

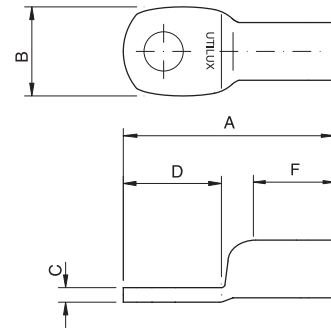

TYPICAL APPLICATIONS

- Overhead connections for electrical distribution systems
- Railway electrification systems where vibration is a concern
- Other sizes available on request

CAT NO.	CONDUCTOR AREA mm ²	BOLT SIZE	DIMENSIONS mm					CRIMPING DIE
			A	B	C	D	F	
CG6SDM6	6	M6	51	16	4.2	21	23	38-77CU
CG6SDM8		M8	51	16	4.2	21	23	
CG6SDM10		M10	51	16	4.2	21	23	
CG10SDM6	10	M6	51	16	4.2	21	23	
CG10SDM8		M8	51	16	4.2	21	23	
CG10SDM10		M10	51	16	4.2	21	23	
CG16SDM8	16	M8	70	21	6.0	27	30	38-104CU
CG16SDM10		M10	70	21	6.0	27	30	
CG16SDM12		M12	70	21	6.0	27	30	
CG25SDM10	25	M10	70	21	6.0	27	30	
CG25SDM12		M12	70	21	6.0	27	30	
CG35SDM10	35	M10	70	21	6.0	27	30	
CG35SDM12		M12	70	21	6.0	27	30	

CONTENTS



ALUMINIUM LUGS AND LINKS

SECTION 2

SECTION 2	ALUMINIUM LUGS AND LINKS	15
	UNILUG FOR ALUMINIUM CABLES	16
	UNILINK ALUMINIUM	17
	ELECTRICAL JOINTING COMPOUND	17
	3 & 4 CORE SECTOR LUG	18
	ROUND BARREL SECTOR	18
	3 & 4 CORE SECTOR LINK	19
	SECTOR TO ROUND LINK	19
	CCT CONDUCTOR	20
	ALUMINIUM ROTATING LUGS	21

UNILUG FOR ALUMINIUM CABLES



- 99.9% pure high conductivity aluminium
 - Forged from solid AL billets
- Solid palm, therefore eliminating the ingress of moisture
 - Pre-filled with joining compound
- Individually packed in sealed plastic bags

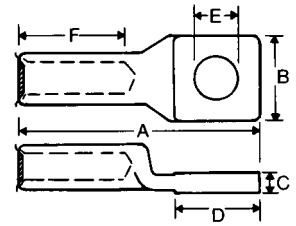

DESCRIPT.	CAT NO.	CONDUCTOR AREA mm ²	STRANDING METRIC	STUD SIZE E	DIMENSIONS mm						CRIMPING DIE
					A	B	C	D	F	I.D.	
AG6MB AG6M6	H15100 H15101	6	7/1.04	MB M6	54	18	5	22	32	3.5	38-90AL
AG10MB AG10M6	H15103 H15104	10	7/1.35	MB M6	65	22	5	22	32	4.5	
AG16MB AG16M10	H15106 H15109	16	7/1.70	MB M10	65	22	5	22	32	5.5	
AG25MB AG25M10	H15111 H15114	25	7/2.14 19/1.35	MB M10	65	22	5	22	32	7.0	
AG35MB AG35M10	H15116 H15119	35	19/1.53	MB M10	65	22	5	22	32	8.5	
AG50MB AG50M10	H15121 H15124	50	19/1.78	MB M10	73	26	8	28	32	9.5	38-132AL
AG70MB AG70M10 AG70M12	H15126 H15129 H15130	70	19/2.14	MB M10 M12	73	26	8	28	32	11.0	
AG95MB AG95M10 AG95M12	H15131 H15134 H15135	95	19/2.52 37/1.78	MB M10 M12	80	30	10	35	32	13.0	
AG120MB AG120M10 AG120M12	H15136 H15138 H15139	120	37/2.03	MB M10 M12	80	30	10	35	32	15.0	38-173AL 40-172AL
AG150MB AG150M10 AG150M12 AG150M16	H15141 H15142 H15143 H15144	150	37/2.25	MB M10 M12 M16	90	36	11	36	30	16.5	38-220AL 40-220AL
AG185MB AG185M12 AG185M16	H15146 H15147 H15148	185	37/2.52	MB M12 M16	90	36	11	36	30	18.5	
AG240MB AG240M12 AG240M16	H15151 H15153 H15154	240	61/2.25	MB M12 M16	115	46	12	50	37	21.0	38-284AL 40-283AL
AG300MB AG300M12 AG300M16	H15156 H15159 H15160	300	61/2.52	MB M12 M16	115	46	12	50	41	23.5	
AG400MB AG400M12 AG400M16	H15162 H15165 H15166	400	61/2.85	MB M12 MB	150	54	15	54	68	26.5	40-390AL
AG500MB AG500M12 AG500M16	H15168 H15171 H15172	500	61/3.20	MB M12 M16	150	54	15	54	68	29.5	
AG630MB AG630M16	H15174 H15176	630	127/2.52	MB M16	159	60	15	60	68	33.5	40-432AL

Stud size "MB" means blank palm.

800-1000mm² tube Aluminium Crimp Lugs made to approved minimum order quantities only.



UNILINK ALUMINIUM

- Solid barrier
- High conductivity Aluminium
- Prefilled with jointing compound
- Individually packed in sealed plastic bags

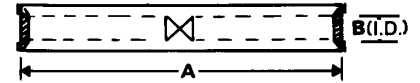

DESCRIPT.	CAT NO.	CONDUCTOR AREA (mm ²)	STRANDING METRIC	DIMENSIONS A (mm) B (mm)		CRIMPING DIE
AK6	H15200	6	7/1.04	70	3.5	38-90AL
AK10	H15201	10	7/1.35	70	4.5	
AK16	H15202	16	7/1.70	70	5.5	
AK25	H15203	25	7/2.14 - 19/1.35	70	7.0	
AK35	H15204	35	19/1.53	70	8.5	38-132AL
AK50	H15205	50	19/1.78	70	9.5	
AK70	H15206	70	19/2.14	70	11.0	38-173AL 40-172AL
AK95	H15207	95	19/2.52 - 37/1.78	124	13.0	
AK120	H15208	120	37/2.03	124	15.0	38-220AL 40-220AL
AK150	H15209	150	37/2.25	124	16.5	
AK185	H15210	185	37/2.52	124	18.5	38-284AL 40-283AL
AK240	H15211	240	61/2.25	124	21.0	
AK300	H15212	300	61/2.52	124	23.5	40-390AL
AK400	H15213	400	61/2.85	146	26.5	
AK500	H15214	500	61/3.20	146	29.5	40-432AL
AK630	H15215	630	127/2.52	146	33.5	
AK800	H15216	800	127/2.85	260	38.5	

Larger sizes available, subject to approved quantities.



ELECTRICAL JOINTING COMPOUND

- Recommended for Aluminium connections
- Zinc particles in H2397 penetrates oxide films that form on the Aluminium surface
 - Seals out air and moisture, therefore minimising oxidation or corrosion and maximising conductivity
 - High melt point grease

CAT NO.	NO.	APPLICATION	PART	COLOUR	TUBE SIZE
H2397	4C	Conductive compound with zinc particles	Zn	KD Grey	325g

3 & 4 CORE SECTOR LUG



- Clear markings on barrel to indicate correct crimping sequence
- Prefilled with jointing compound
- Supplied with flat washers
 - Suit 3 core 120° or 4 core 90° solid sector aluminium conductor
- 99.9% pure, high conductivity Aluminium
- Individually packed in sealed plastic bags

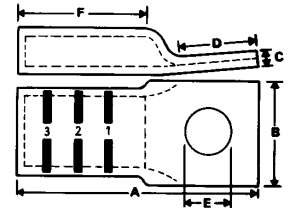

DESCRIPT.	CAT NO.	CONDUCTOR AREA mm ²	STUD SIZE E	DIMENSIONS mm					TOOL NO.	DIES NEST	DIES INDENT
				A	B	C	D	F			
3 CORE											
AGS120M12	H8610	120	M12	100	31	6.9	33.5	51	38A	12	16
AGS150M12	H8611	150	M12	103	35	7.3	33.5	51	38A	12	17
AGS185M12	H8613	185	M12	115	38	7.3	37.3	59	38A	12	18
AGS240M12	H8615	240	M12	123	42	8.7	37.3	63	38A	12	19
AGS240M16	H8616	240	M16	123	42	8.7	37.3	63	38A	12	19
4 CORE											
AGI120M12	H8889	120	M12	101.6	32	6.7	34.9	53.9	38A	14	16
AGI150M12	H8890	150	M12	110.3	35	7.1	34.9	59.5	38A	14	17
AGI185M12	H8891	185	M12	115.0	40	8.3	38.1	59.5	38A	14	18
AGI240M12	H8892	240	M12	127.8	46	11.7	44.4	62.6	38A	15	19

ROUND BARREL SECTOR

- 99.9% pure high conductivity aluminium
- Forged from solid AL billets
- Solid palm, therefore eliminating the ingress of moisture
 - Pre-filled with jointing compound
- Individually packed in sealed plastic bags
 - Hexcrimp with std Utilux dies

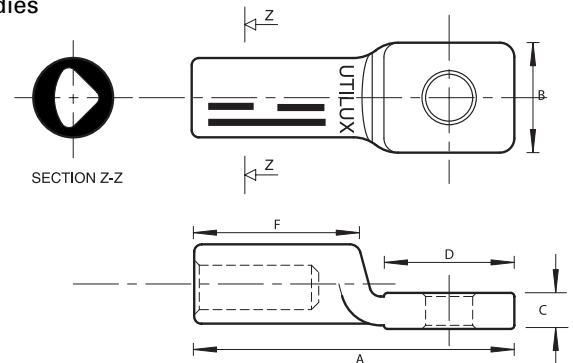

DESCRIPT.	CAT NO.	DIMENSIONS mm					CRIMPING DIE	
		A	B	C	D	F		
AG4H185M12	H50804	115	36	11	36	62	38-220AL	40-220AL
AG4H240M12	H50805	133	36	12	36	62	38-284AL	40-283AL

3 & 4 CORE SECTOR LINK



- Clear markings on barrel to indicate correct crimping sequence
 - Prefilled with jointing compound
- Suit 3 core 120° or 4 core 90° solid sector aluminium conductor
- 99.9% pure, high conductivity aluminium
- Individually packed in sealed plastic bags

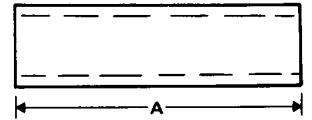

DESCRIPT.	CAT NO.	CONDUCTOR AREA mm ²	mm A	TOOL NO.	NEST	DIES INDENT
3 CORE						
AKS120	H8627	120	90	38A	12	16
AKS150	H8628	150	90	38A	12	17
AKS185	H8629	185	105	38A	12	18
AKS240	H8630	240	110	38A	12	19
4 CORE						
AKI120	H8949	120	88.9	38A	14	16
AKI150	H8950	150	104.8	38A	14	17
AKI185	H8951	185	104.8	38A	14	18
AKI240	H8952	240	114.3	38A	15	19

2

SECTOR TO ROUND LINK



- Clear markings on barrel to indicate correct crimping sequence
 - Prefilled with jointing compound
- Suit 3 core 120° or 4 core 90° solid sector aluminium conductor
- 99.9% pure, high conductivity aluminium
- Individually packed in sealed plastic bags

DESCRIPT. P/N	CONDUCTOR SECTOR mm ²	CONDUCTOR ROUND mm ²	OVERALL LENGTH	ROUND END HEXCRIMP DIE	SECTOR CRIMP NEST DIE	SECTOR CRIMP INDENT DIE
3 CORE						
AK3185240	185	240	150	38-284AL	#12 NEST	#18 INDENT
AK31240300	240	300	150	38-284AL	#15 NEST	#20 INDENT
4 CORE						
AK41240300	240	300	153	38-284AL	#15 NEST	#20 INDENT

CCT CONDUCTOR



The new aluminium lugs & links are designed for use with 7/2.75 (40mmsq) Aluminium CCT conductor.

The lug is primarily used on dropper cables for pole mounted substations. An aluminium link is also provided for in line connections.

The lug and link are manufactured from 99.9% pure high conductivity aluminium. They are forged to maximise conductivity and strength.

The solid palm also eliminates the ingress of moisture whilst the plating gives added protection for outdoor use.

The lug and link are pre-filled with jointing compound, ink stamped with catalogue number and crimping details and individually packed in sealed plastic bags.

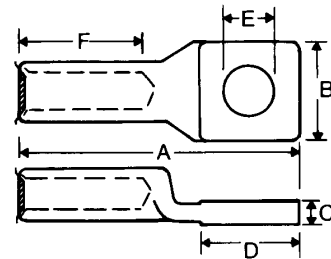

CAT NO.	CONDUCTOR SIZE	DIMENSIONS mm							CRIMPING DIE
		A	B	C	D	E	F		
LUG AG40M10ET	7/2.75 (40mmSQ)	73	26	8	28	M12	32	38-132AL	
LUG AG40M12ET	7/2.75 (40mmSQ)	70	26	8	28	M12	32	38-132AL	
LINK AK40ET	7/2.75 (40mmSQ)	70	N/A	N/A	N/A	N/A	N/A	38-132AL	



A NEW SOLUTION FOR CONNECTING UNDERGROUND ALUMINIUM CABLES



This new range of connectors for aluminium 4 core sector cable features a unique concept enabling the lug to be rotated to any desired position on the conductor, without the need to round the conductor first. The design embodies the tried and proven round barrel/hex compression die combination, giving superior connection reliability.

BENEFITS:

- The lug can be rotated to any desired position
- No need to twist conductor to correct orientation

- Minimum effort required to correctly orientate lug
- Reduces total connection time
- Suits solid and stranded conductor types
- Uses standard size hexagonal dies
- No need to round the sector cable first
- Bi-metal versions available
- No voids when crimped
- Takes two crimps on the barrel without overlapping
- Palm will fit into most receptacles found in URD system
- Supplied pre-packed with jointing compound, in sealed plastic bags
- The lug barrel has markings showing the length of insulation to be stripped
- Made from high conductivity, high strength, solid forged aluminium
- Tested to BS4579

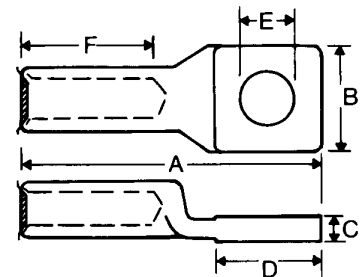

ALUMINIUM ROTATING LUGS

DESCRIPT.	CAT NO.	CONDUCTOR AREA mm ²	DIMENSIONS mm							STUD E	CRIMPING DIE
			A	F	OD	B	C	D			
AG4HR185MB	H15353	185	112	50	34	36	12	36	MB	38-284AL	
AG4HR185M12	H15354	185	112	50	34	36	12	36	M12		
AG4HR185M16	H15355	185	112	50	34	36	12	36	M16		
AG4HR240MB	H15356	240	112	50	34	36	12	50	MB	38-284AL	
AG4HR240M12	H15357	240	112	50	34	36	12	50	M12		
AG4HR240M16	H15358	240	112	50	34	36	12	50	M16		

CONTENTS

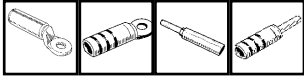

BI-METAL LUGS AND LINKS

SECTION 3

SECTION 3	BI-METAL LUGS AND LINKS23
	BI-METAL CRIMP LUG24
	BI-METAL CRIMP LINK25
	3 & 4 CORE SECTOR	
	BI-METAL LUG – (SOLID ONLY)26
	3 & 4 CORE SECTOR	
	BI-METAL LINK – (SOLID ONLY)27
	BI-METAL CRIMP STALK LUG28
	3 & 4 CORE SECTOR	
	BI-METAL STALK – (SOLID ONLY)28
	BI-METAL ROTATING LUGS29
	BI-METAL ROTATING LINK29
	BI-METAL LONG PALM LUGS30
	BI-METAL REVERSE LUGS30

CATALOGUE INDEX

INDEX

BI-METAL CRIMP LUG

- For aluminium to copper terminations • Friction welded
- Manufactured from high purity copper and aluminium rod
- Stepped barrel OD sizes across all bi-metal allows rationalisation of die inventory
- Pre-filled with jointing compound • Individually packed in sealed plastic bags
- Reverse bi-metal (aluminium palm, copper barrel)
- lugs are manufactured to approved order quantities
- Alternative sizes can be made to order for approved order quantities

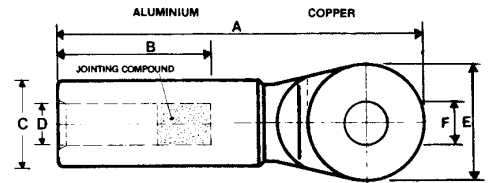

DESCRPT.	CAT NO.	CONDUCTOR AREA mm ²	STRANDING METRIC	DIMENSIONS mm					STUD SIZE F	PALM THICK	CRIMPING DIE
				A	B	C	D	E			
BG16MB BG16M10	H15304 H15305	16	7/1.70	75.0	32.0	12.0	5.5	22.0	MB M10	4.5	38-90AL
BG25MB BG25M10	H15306 H15307	25	19/1.35	75.0	32.0	12.0	7.0	22.0	MB M10	4.5	
BG35MB BG35M10 BG35M12	H15308 H15309 H15310	35	19/1.53	75.0	32.0	12.0	8.5	22.0	MB M10 M12	4.5	
BG50MB BG50M10 BG50M12	H15311 H15312 H15313	50	19/1.78	75.0	32.0	16.0	9.5	22.0	MB M10 M12	4.5	38-132AL
BG70MB BG70M10 BG70M12	H15314 H15315 H15316	70	19/2.14	75.0	32.0	16.0	11.0	22.0	MB M10 M12	4.5	
BG95MB BG95M10 BG95M12	H15317 H15318 H15319	95	37/1.78	115.0	60.0	21.5	13.0	32.0	MB M10 M12	6.0	38-173AL 40-172AL
BG120MB BG120M12 BG120M16	H15320 H15321 H15322	120	37/2.03	115.0	60.0	21.5	15.0	32.0	MB M12 M16	6.0	
BG150MB BG150M12 BG150M16	H15323 H15324 H15325	150	37/2.25	120.0	60.0	27.0	16.5	36.0	MB M12 M16	7.0	38-220AL 40-220AL
BG185MB BG185M12 BG185M16	H15326 H15327 H15328	185	37/2.52	120.0	60.0	27.0	18.5	36.0	MB M12 M16	7.0	
BG240MB BG240M12 BG240M16	H15329 H15330 H15331	240	61/2.25	130.0	60.0	35.0	21.0	42.0	MB M12 M16	7.0	38-284AL 40-283AL
BG300MB BG300M12	H15332 H15333	300	61/2.52	130.0	60.0	35.0	23.5	42.0	MB M12	7.0	
BG400MB	*H15334	400	61/2.85	160.0	70.0	47.0	26.5	50.0	MB	10.0	40-390AL
BG500MB	*H15335	500	61/3.20	160.0	70.0	47.0	29.5	50.0	MB	10.0	
BG630MB	*H15336	630	127/2.52	175.0	70.0	54.0	33.5	60.0	MB	10.0	40-432AL
BG800MB	*H15337	800	127/2.85	221.0	115.0	54.0	39.0	60.0	MB	10.0	

*Square palms

BI-METAL CRIMP LINK

Suitable for aluminium to copper in line terminations

- Friction welded
- Manufactured for high purity copper and aluminium rod
- Prefilled with joint compound
- Individually packed in sealed plastic bags

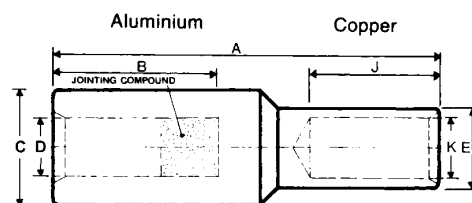

DESCRIPT.	CAT NO.	CONDUCTOR AREA mm ²	STRANDING METRIC	ALUMINIUM				CRIMPING DIE	COPPER			CRIMPING DIE
				DIMENSIONS mm					DIMENSIONS mm			
				A	B	C	D	E	J	K		
BK16/10	H15404	16/10	7/1.70-7/1.35	70.0	32.0	12.0	5.5	38-90AL	11.5	21.5	4.5	38-92CU
BK16/16	H15405	16/16	7/1.70-7/1.70									
BK25/16	H15406	25/16	19/1.35-7/1.70	70.0	32.0	12.0	7.0	38-90AL	11.5	21.5	5.5	
BK25/25	H15407	25/25	19/1.35-19/1.35									
BK35/25	H15408	35/25	19/1.53-19/1.35	70.0	32.0	12.0	8.5	38-90AL	11.5	21.5	7.0	
BK35/35	H15409	35/35	19/1.35-19/1.53									
BK50/35	H15410	50/35	19/1.78-19/1.53	70.0	32.0	16.0	9.5	38-132AL	11.5	21.5	8.5	
BK50/50	H15411	50/50	19/1.78-19/1.78									70.0
BK70/50	H15412	70/50	19/2.14-19/1.78	70.0	32.0	16.0	11.0	38-173AL	14.5	32.0	11.0	
BK70/70	H15413	70/70	19/2.14-19/2.14									110.0
BK95/70	H15414	95/70	37/1.78-19/2.14	120.0	60.0	21.5	15.0	38-173AL	20.5	40.0	13.0	
BK95/95	H15415	95/95	37/1.78-37/1.78									120.0
BK120/95	H15416	120/95	37/2.03-37/1.78	120.0	60.0	27.0	16.5	38-173AL	20.5	40.0	15.0	
BK120/120	H15417	120/120	37/2.03-37/2.03									120.0
BK150/120	H15418	150/120	37/2.25-37/2.03	120.0	60.0	27.0	18.5	38/40-220AL	24.5	40.0	16.5	
BK150/150	H15419	150/150	37/2.25-37/2.25									120.0
BK185/150	H15420	185/150	37/2.52-37/2.25	120.0	60.0	27.0	21.0	38-284AL	24.5	40.0	18.5	
BK185/185	H15421	185/185	37/2.52-37/2.52									122.0
BK240/185	H15422	240/185	61/2.25-37/2.52	125.0	60.0	35.0	23.5	38-284AL	32.0	40.0	21.0	
BK240/240	H15423	240/240	61/2.25-61/2.25									125.0
BK300/240	H15424	300/240	61/2.52-61/2.25	153.0	70.0	47.0	26.5	40-390AL	32.0	55.0	23.5	
BK300/300	H15425	300/300	61/2.52-61/2.52									155.0
BK400/300	H15426	400/300	61/2.85-61/2.52	155.0	70.0	47.0	29.5	40-390AL	38.5	58.0	26.5	
BK400/400	H15427	400/400	61/2.85-61/2.85									155.0
BK500/400	H15428	500/400	61/3.20-61/2.85	160.0	70.0	54.0	33.5	40-432AL	45	60.0	33.5	
BK500/500	H15429	500/500	61/3.20-61/3.20									160.0
BK630/500	H15430	630/500	127/2.52-61/3.20	160.0	70.0	54.0	33.5	40-432AL	45	60.0	33.5	
BK630/630	H15431	630/630	127/2.52-127/3.20									160.0

3 & 4 CORE SECTOR BI-METAL LUG - (solid only)



- Suitable for 3 or 4 core solid sector cable
- Clear markings on the barrel indicate the crimping sequence
 - Pre-filled with jointing compound
- Individually packed in sealed plastic bags
 - Friction welded
- For aluminium to copper termination and manufactured from high purity copper and aluminium rod

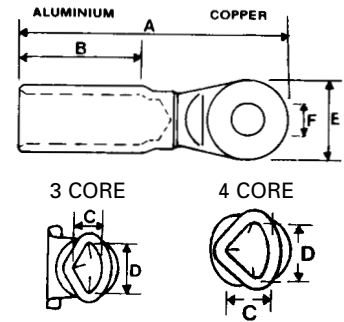

DESCRIPT.	CAT NO.	CONDUCTOR AREA mm ²	DIMENSIONS mm					STUD F	PALM THICK	38A DIES		
			A	B	C	D	E			NEST	INDENT	
3 CORE												
BGS120MB	H15610	120	111	49	10.6	18.1	32	6.0	MB	12	16	
BGS120M12	H15611											M12
BGS150MB	H15612	150	116	49	11.8	20.1	36	7.0	MB	12	17	
BGS150M12	H15613											M12
BGS185MB	H15614	185	126	57	13.2	22.5	36	7.0	MB	12	18	
BGS185M12	H15615											M12
BGS240MB	H15616	240	138	61	15.2	25.8	42	7.0	MB	12	19	
BGS240M12	H15619											M12
BGS240M16	H15617											M16
BGS300MB	H15618	300	147	61	19.4	27.2	42	7.0	MB	12	21	
4 CORE												
BGI120MB	H15660	120	111	49	12.1	17.1	32	6.0	MB	14	16	
BGI120M12	H15661											M10
BGI185MB	H15664	185	126	57	15.1	21.2	36	7.0	MB	14	18	
BGI185M12	H15665											M12
BGI240MB	H15666	240	136	61	17.5	24.6	42	7.0	MB	14	19	
BGI240M12	H15667											M16
BGI300MB	H15668	300	147	61	19.4	27.2	42	7.0	MB	15	21	
BGI300M16	H15669											M16

3 & 4 CORE SECTOR BI-METAL LINK - (solid only)



- Suitable for 3 or 4 core solid sector cable
- Clear markings on the barrel indicate the crimping sequence
 - Pre-filled with jointing compound
- Individually packed in sealed plastic bags
 - Friction welded
- For aluminium to copper termination
- Manufactured from high purity copper and aluminium rod

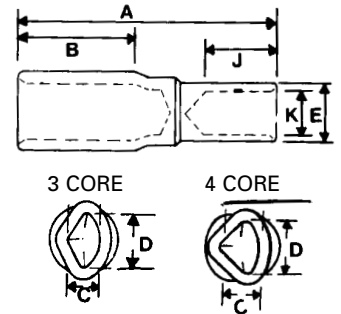

DESCRPT.	CAT. NO.	ALUMINIUM				DIMENSIONS							COPPER		CRIMPING DIE
		CONDUCTOR AREA mm ² AL	38 DIES NEST	INDENT	STRANDING METRIC	A	B	C	D	E	J	K	CONDUCTOR AREA mm ² CU		
3 CORE															
BKS120/70	H15710	120	12	16	19/2.14	106.0	49.0	10.6	18.1	14.5	32.0	11.0	70	38-115CU	
BKS120/120	H15711	120	12	16	37/2.03	116.0	49.0	10.6	18.1	20.5	40.0	15.0	120	38-165CU	
BKS150/95	H15712	150	12	17	37/1.78	116.0	49.0	11.8	20.1	20.5	40.0	13.0	95	38-165CU	
BKS150/150	H15713	150	12	17	37/2.25	116.0	49.0	11.8	20.1	24.5	40.0	16.5	150	38-200CU	
BKS185/120	H15714	185	12	18	37/2.03	126.0	57.0	13.2	22.5	20.5	40.0	15.0	120	38-165CU	
BKS185/185	H15715	185	12	18	37/2.52	126.0	57.0	13.2	22.5	24.5	40.0	18.5	185	38-200CU	
BKS240/150	H15716	240	12	19	37/2.25	131.0	61.0	15.2	25.8	24.5	40.0	16.5	150	38-200CU	
BKS240/240	H15717	240	12	19	61/2.25	134.0	61.0	15.2	25.8	32.0	40.0	21.0	240	38-260CU	
4 CORE															
BKI70/50	H15756	70	14	14	19/1.78	88	43	9.0	13.5	14.5	22	9.5	50	38-115CU	
BKI70/70	H15757	70	14	14	19/2.14	88	43	9.0	13.5	14.5	22	11.0	70	38-115CU	
BKI95/70	H15758	95	14	15	19/2.14	106	49	10.5	14.8	14.5	32	11.0	70	38-115CU	
BKI95/95	H15759	95	14	15	37/1.78	116	49	10.5	14.8	20.5	40	13.0	95	38-165CU	
BKI120/70	H15760	120	14	16	19/2.14	106	49	12.1	17.1	14.5	32	11.0	70	38-115CU	
BKI120/120	H15761	120	14	16	37/2.03	116	49	12.1	17.1	20.5	40	15.0	120	38-165CU	
BKI150/95	H15762	150	14	17	37/1.78	116	49	13.6	19.1	20.5	40	13.0	95	38-165CU	
BKI150/150	H15763	150	14	17	37/2.25	116	49	13.6	19.1	24.5	40	16.5	150	38-200CU	
BKI185/120	H15764	185	14	18	37/2.03	126	57	15.1	21.2	20.5	40	15.0	120	38-165CU	
BKI185/185	H15765	185	14	18	37/2.52	126	57	15.1	21.2	24.5	40	18.5	185	38-200CU	
BKI240/150	H15766	240	14	19	37/2.25	131	61	17.5	24.6	24.5	40	16.5	150	38-200CU	
BKI240/240	H15767	240	14	19	61/2.25	134	61	17.5	24.6	32.0	40	21.0	240	38-260CU	
BKI300/185	H15768	300	14	21	37/2.52	140	61	19.4	27.2	24.5	40	18.5	185	38-200CU	
BKI300/300	H15769	300	14	12	61/2.52	143	61	19.4	27.2	32.0	40	23.5	300	38-260CU	



BI-METAL CRIMP STALK LUG

- Suitable for aluminium to copper terminations
 - Friction welded
- Manufactured from high purity copper and aluminium
- Prefilled with jointing compound
- Individually packed in sealed plastic bags

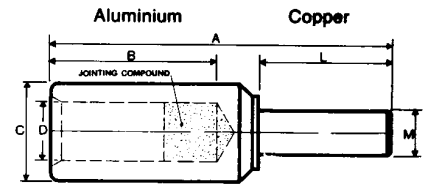

DESCRIPT.	CAT. NO.	CONDUCTOR AREA mm ²	STRANDING METRIC	A	B	C	D	L	M	CRIMPING DIE
BS16/12	H15502	16	7/1.70	70	32	12	5.5	30	12	38-90AL
BS25/12	H15503	25	19/1.35	70	32	12	7.0	30	12	
BS35/12	H15504	35	19/1.53	70	32	12	8.5	30	12	
BS50/12	H15505	50	19/1.78	70	32	16	9.5	30	12	38-132AL
BS70/12	H15506	70	19/2.14	70	32	16	11.0	30	12	
BS95/12	H15507	95	37/1.78	110	60	21.5	13.0	38	12	38-173AL 40-172AL
BS120/12	H15508	120	37/2.03	110	60	21.5	15.0	38	12	
BS120/14	H15509		14							
BS150/12	H15510	150	37/2.25	120	60	27	16.5	48	12	38-220AL 40-220AL
BS150/14	H15511								14	
BS185/16	H15512	185	37/2.25	120	60	27	18.5	48	16	38-284AL 40-283AL
BS185/18	H15513								18	
BS240/16	H15514	240	61/2.25	122	60	35	21.0	48	16	38-284AL 40-283AL
BS240/18	H15515								18	
BS300/16	H15516	300	61/2.52	122	60	35	23.5	48	16	40-390AL
BS300/18	H15517								18	
BS400/18	H15518	400	61/2.85	153	70	47	26.5	65	18	40-390AL
BS400/20	H15519								20	
BS500/18	H15520	500	61/3.20	153	70	47	29.5	65	18	40-432AL
BS500/20	H15521								20	
BS630/20	H15522	630	127/2.52	160	70	54	33.5	70	20	

Alternative stalk sizes can be manufactured to approved minimum order quantities



3 & 4 CORE SECTOR BI-METAL STALK - (solid only)

- Suitable for 3 or 4 core solid sector cable
- Clear markings on the barrel indicate the crimping sequence
 - Prefilled with jointing compound
- Individually packed in sealed plastic bags
 - Friction welded
- For aluminium to copper terminations
- Manufactured from high purity copper and aluminium rod

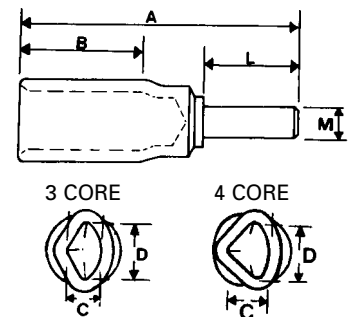

DESCRIPT.	CAT NO.	CONDUCTOR AREA mm ²	A	B	C	D	L	M	38A DIES	
									NEST	INDENT
3 CORE										
BSS240/16	H15816	240	134	61	15.2	25.8	48.0	16.0	12	19
4 CORE										
BSI70/12	H15856	70	88	43	9.0	12.5	30	12	14	14
BSI95/12	H15858	95	108	49	10.5	14.8	38	12	14	15
BSI120/12	H15860	120	118	49	12.1	17.1	48	12	14	16
BSI150/12	H15862	150	119	49	13.6	19.1	48	12	14	17
BSI185/16	H15864	185	129	57	15.1	21.2	48	16	14	18
BSI240/16	H15866	240	134	61	17.5	24.6	48	16	14	19
BSI300/16	H15868	300	143	61	19.4	27.2	48	16	14	21

ROTATING BI-METAL LUGS & LINK

This new range of connectors for aluminium 4 core sector cable features a unique concept enabling the lug to be rotated to any desired position on the conductor, without the need to round the conductor first. The design embodies the tried and proven round barrel/hex compression die combination, giving superior connection reliability.

BENEFITS:

- The lug can be rotated to any desired position
 - No voids when crimped
- No need to twist conductor to correct orientation
- Takes two crimps on the barrel without overlapping
- Minimum effort required to correctly orientate lug
- Palm will fit into most receptacles found in URD system
 - Reduces total connection time
- Supplied pre-packed with jointing compound, in sealed plastic bags
 - Suits solid and standard conductor types
- The lug barrel has markings showing the length of insulation to be stripped
 - Uses standard size hexagonal dies
- Made from high conductivity, high strength, solid forged aluminium
 - No need to round the sector cable first
 - Tested to BS4579

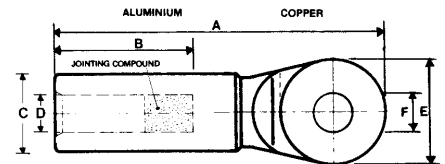

DESCRIPT.	CAT NO.	CONDUCTOR AREA mm ²	DIMENSIONSmm			PALM THICK	STUD F	CRIMPING DIE
			A	B	E			
BG4HR185MB	H15362	185	119	50	36	7.0	MB	38-284AL
BG4HR185M12	H15363	185	119	50	36	7.0	M12	38-284AL
BG4HR185M16	H15364	185	119	50	36	7.0	M16	38-284AL
BG4HR240MB	H15365	240	126	50	42	7.0	MB	38-284AL
BG4HR240M12	H15366	240	126	50	42	7.0	M12	38-284AL
BG4HR240M16	H15367	240	126	50	42	7.0	M16	38-284AL

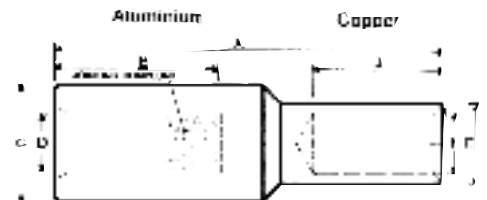

DESCRIPT.	CONDUCTOR AREA mm ²		ALUMINIUM		CRIMPING DIE	COPPER			CRIMPING DIE
			DIMENSIONS mm			DIMENSIONS mm			
	A	B	A	B		E	J	K	
BK4HR240150	240	150	110	50	38-284AL	24.5	40	16.5	38-200CU
	4 core sector								

BI-METAL LONG PALM LUGS

- For two bolt termination applications • Blank palm, 105mm long x 50mm wide
- Friction welded high purity aluminium and copper rod • Eliminates electrolytic corrosion
- Clearly marked with cable size, die recommendation and crimping position • Pre-filled with jointing compound
- Individually packed in plastic bags • Palms can be drilled to customers bolt hole specification

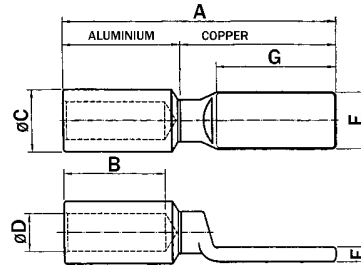

DESCRIPT.	CONDUCTOR AREA mm ²	DIMENSIONS mm							CRIMPING DIE
		A	B	C	D	E	F	G	
BG240LPMB	240	209	60	35	21	50	13	105	38-284AL
BG300LPMB	300	209	60	35	23.5	50	13	105	
BG400LPMB	400	221	70	47	26.5	50	13	105	
BG500LPMB	500	221	70	47	29.5	50	13	105	40-390AL
BG630LPMB	630	221	70	54	33.5	50	13	105	
BG800LPMB	800	266	105	54	39	50	13	105	40-432AL

BI-METAL REVERSE LUGS

- Used for connection of copper conductor to aluminium terminal • Blank aluminium palm and copper barrel
- Friction welded high purity aluminium and copper rod • Eliminates electrolytic corrosion
- Clearly marked with crimping position

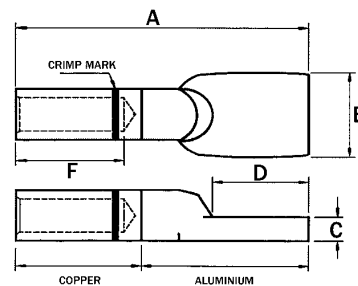

DESCRIPT.	CONDUCTOR AREA mm ²	DIMENSIONS mm					CRIMPING DIE
		A	B	C	D	F	
BGRV25MB	25	70	23	4.5	24	22	38-92CU
BGRV35MB	35	70	23	4.5	24	22	38-92CU
BGRV50MB	50	78	27	6.0	28	22	38-115CU
BGRV70MB	70	78	27	6.0	28	22	38-115CU
BGRV95MB	95	103	34	9.8	34	38	38-165CU
BGRV120MB	120	103	34	9.8	34	38	38-165CU

CONTENTS

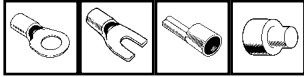

UNINSULATED & PREINSULATE TERMINALS

SECTION 4

SECTION 4	BI-METAL LUGS & LINKS NON-INSULATED PRE-INSULATED LUGS & LINKS . . .31
	UNINSULATED RING TERMINAL UTILUG32
	PRE-INSULATED RING TERMINAL UTILUG33
	RING TERMINAL SUPERGRIP UTILUG34
	UNINSULATED FORK UTILUG35
	SUPERGRIP FORK UTILUG35
	PRE-INSULATED FORK UTILUG36
	HIGH TEMPERATURE UTILUG RING TERMINAL36
	HEAVY DUTY INSULATED RING TERMINAL37
	BOOTLACE FERRULES37
	DUAL BOOTLACE FERRULES37
	UNINSULATED CRIMP PIN CONNECTOR38
	PRE-INSULATED PIN CONNECTOR38
	SUPERGRIP PIN CONNECTOR38
	PRE-INSULATED AND SUPERGRIP CRIMP LINK CABLE CONNECTOR39
	CLOSED END PRE-INSULATED CABLE CONNECTOR39
	HEAVY DUTY PRE-INSULATED
	CRIMP LINK CONNECTOR40
	2.8MM Q.C. RECEPTACLE40
	4.8MM Q.C. RECEPTACLES TO SUIT
	0.5MM TABS40
	6.3MM Q.C. RECEPTACLES TO SUIT
	0.8MM TABS41
	6.3MM Q.C. TABS41
	6.3MM ADAPTORS Q.C. PIGGY BACK41
	9.3MM Q.C. RECEPTACLES41
	LIP BLADE TERMINALS42
	BULLET TERMINAL42
	BULLET RECEPTACLE42
	LOOSE PIECE BRASS CONNECTORS43
	TK22 ELECTRICAL TERMINAL KIT44

UNINSULATED RING TERMINAL UTILUG



- Electro tinned to minimise corrosion
- Serrated barrel provides secure mechanical and electrical connection
- Also available in continuous strip form
- Suitable for small flexible cables

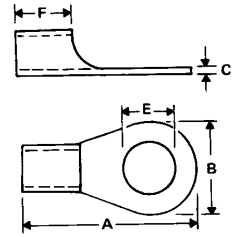

DESCRPT.	CAT NO.	TERMINAL SIZE	CONDUCTOR AREA mm ²	STUD SIZE	DIMENSIONS mm					TOOL NO.
					A	B	C	E	F	
UR1.5M1.6	H3110	NO.1 22-16AWG	0.5	M1.6	12.5	5.5	0.7	2.5	4.8	00 76A 16B 18 63-1
UR1.5M3S	H3111			M3	12.5	5.5	0.7	3.7	4.8	
UR1.5M3M	H3116			M3	14.4	6.6	0.7	3.7	4.8	
UR1.5M3L	H3112			M3	15.8	8.0	0.7	3.7	4.8	
UR1.5M4S	H3113			M4	14.4	6.6	0.7	4.3	4.8	
UR1.5M4L	H3114		M4	15.8	8.0	0.7	4.3	4.8		
UR1.5M5S	H3115		M5	15.8	8.0	0.7	5.3	4.8		
UR1.5M5L	H3117		M5	21.8	11.6	0.7	5.3	4.8		
UR1.5M6	H3118		M6	21.8	11.6	0.7	6.4	4.8		
UR1.5M8	H3119		M8	21.8	11.6	0.7	8.4	4.8		
UR1.5M10	H3140	M10	25.5	13.6	0.7	10.5	4.8			
UR2.5M3S	H3120	NO.2 16-14AWG	1.5	M3	14.4	6.6	0.8	3.7	4.8	00 76A 16B 18 63-1
UR2.5M3L	H3121			M3	16.8	8.5	0.8	3.7	4.8	
UR2.5M4S	H3122			M4	14.4	6.6	0.8	4.3	4.8	
UR2.5M4L	H3123			M4	16.8	8.5	0.8	4.3	4.8	
UR2.5M5S	H3125		M5	16.8	8.5	0.8	5.3	4.8		
UR2.5M5L	H3126		M5	16.8	9.5	0.8	5.3	4.8		
UR2.5M6	H3127		M6	21.8	12.0	0.8	6.4	4.8		
UR2.5M8	H3128		M8	21.8	12.0	0.8	8.4	4.8		
UR2.5M10	H3129	M10	25.5	13.6	0.8	10.5	4.8			
UR6M3	H3132	NO.3 12-10AWG	2.5	M3	15.7	7.2	1.0	3.7	6.0	00 76A 16B 18 63-1 124
UR6M4S	H3130			M4	15.7	7.2	1.0	4.3	6.0	
UR6M4L	H3131			M4	19.6	9.5	1.0	4.3	6.0	
UR6M5	H3133			M5	19.6	9.5	1.0	5.3	6.0	
UR6M6	H3134			M6	22.5	12.0	1.0	6.4	6.0	
UR6M8	H3137		M8	27.0	15.0	1.0	8.4	6.0		
UR6M10	H3138		M10	27.0	15.0	1.0	10.5	6.0		
UR6M12	H3139		M12	31.6	19.2	1.0	13.0	6.0		
UR6M16	H3161		M16	47.6	31.8	0.9	31.8	6.6		
UR6M18	H3162		M18	47.6	31.8	0.9	31.8	6.6		
UR8.5M6	H3183	NO.4 10-8AWG	6.0	M6	23.8	12.0	1.2	6.4	8.5	00 18 124
UR8.5M10	H3185A		TO	M10	29.8	15.0	1.2	10.5	8.5	
UR8.5M16	H3187A		8.5	M16	50.0	31.6	1.2	15.0	8.5	
UR20M12	H1851B	5AWG	20.0	M12	54.0	31.8	1.8	15.0	15.9	20
UR20M16	H1851	5AWG	20.0	M16	54.0	31.8	1.8	15.0	15.9	

PRE-INSULATED RING TERMINAL UTILUG

- Copper electro tinned to minimise corrosion
- PVC insulation for insulation support

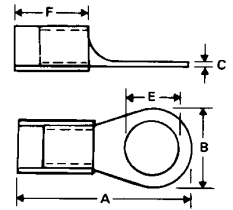

DESCRIPT.	CAT NO.	TERMINAL SIZE	CONDUCTOR AREA mm ²	STUD SIZE	A	DIMENSIONS mm				MAX. INSUL. DIA. mm	TOOL NO.
						B	C	E	F		
RRM1.6	H4110	NO.1 RED 22-16AWG	0.5 TO 1.5	M1.6	17.5	5.5	0.7	3.2	10.0	3.5	76A 11C 11B 63-4B 102 120
RRM3S	H4111			M3	17.5	5.5	0.7	3.7	10.0		
RRM3M	H4116			M3	19.4	6.6	0.7	3.7	10.0		
RRM3L	H4112			M3	20.8	8.0	0.7	3.7	10.0		
RRM4S	H4113			M4	19.4	6.6	0.7	4.3	10.0		
RRM4L	H4114			M4	20.8	8.0	0.7	4.3	10.0		
RRM5S	H4115			M5	20.8	8.0	0.7	5.3	10.0		
RRM5L	H4117			M5	26.8	11.6	0.7	5.3	10.0		
RRM6	H4118			M6	26.8	11.6	0.7	6.4	10.0		
RRM8	H4119			M8	26.8	11.6	0.7	8.4	10.0		
RRM10	H4140	M10	30.5	13.6	0.7	10.5	10.0				
BRM3S	H4120	NO.2 BLUE 16-14AWG	1.5 TO 2.5	M3	19.4	6.6	0.8	3.7	10.0	4.3	76A 12C 12B 63-4U 102 120
BRM3L	H4121			M3	21.8	8.5	0.8	3.7	10.0		
BRM4M	H4124			M4	17.8	6.6	0.8	3.7	10.0		
BRM4S	H4122			M4	19.4	6.6	0.8	4.3	10.0		
BRM4L	H4123			M4	21.8	8.5	0.8	4.3	10.0		
BRM5S	H4125			M5	21.8	8.5	0.8	5.3	10.0		
BRM5L	H4126			M5	21.8	9.5	0.8	5.3	10.0		
BRM6	H4127			M6	26.8	12.0	0.8	6.4	10.0		
BRM8	H4128			M8	26.8	12.0	0.8	8.4	10.0		
BRM10	H4129			M10	30.5	13.6	0.8	10.5	10.0		
YRM3	H4132	NO.3 YELLOW 12-10AWG	2.5 TO 6.0	M3	22.7	7.2	1.0	3.7	10.0	6.1	76A 13B 63-5U 102 120
YRM4S	H4130			M4	22.7	7.2	1.0	4.3	10.0		
YRM4L	H4131			M4	26.6	9.5	1.0	4.3	10.0		
YRM5	H4133			M5	26.6	9.5	1.0	5.3	10.0		
YRM6	H4134			M6	29.5	12.0	1.0	6.4	10.0		
YRM8	H4137			M8	34.0	15.0	1.0	8.4	10.0		
YRM10	H4138			M10	34.0	15.0	1.0	10.5	10.0		
YRM12	H4139			M12	38.6	19.2	1.0	13.0	10.0		
YRM18	H4162			M18	54.8	31.8	0.9	31.8	13.5		

RING TERMINAL SUPERGRIP UTILUG



- Fitted with a copper ferrule and pre-insulated for secure insulation support
- Copper electro tinned to minimise corrosion
- Serrated barrel provides secure mechanical and electrical connection

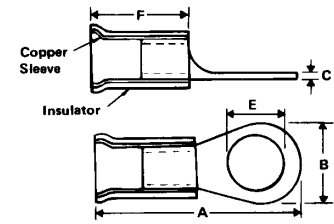
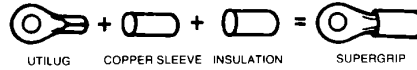

DESCRIPT.	CAT NO.	TERMINAL SIZE	CONDUCTOR AREA mm ²	STUD SIZE	DIMENSIONS mm					MAX. INSUL. DIA. mm	TOOL NO.		
					A	B	C	E	F				
MYRSGM4	H4202	YELLOW	0.2 TO	M4	19.0	6.6	0.5	6.6	8.0	2.4	78		
MYRSGM5	H4203	26-22AWG	0.5	M5	19.0	8.0	0.5	8.0	8.0				
RRSGM1.6	H4210	NO.1	0.5	M1.6	18.0	5.5	0.7	3.2	10.5	3.5	11C 11B 76B 63-4B 102 120		
RRSGM3S	H4211			M3	18.0	5.5	0.7	3.7	10.5				
RRSGM3M	H4216			M3	19.9	6.6	0.7	3.7	10.5				
RRSGM3L	H4212			M3	21.3	8.0	0.7	3.7	10.5				
RRSGM4S	H4213			M4	19.9	6.6	0.7	4.3	10.5				
RRSGM4L	H4214			RED	TO	M4	21.3	8.0	0.7			4.3	10.5
RRSGM5S	H4215			M5	21.3	8.0	0.7	5.3	10.5				
RRSGM5L	H4217			22-16AWG	1.5	M5	27.3	11.6	0.7			5.3	10.5
RRSGM6	H4218			M6	27.3	11.6	0.7	6.4	10.5				
RRSGM8	H4219			M8	27.3	11.6	0.7	8.4	10.5				
RRSGM10	H4240	M10	31.0	13.6	0.7	10.5	10.5						
BRS GM3S	H4220	NO.2	1.5	M3	19.9	6.6	0.8	3.7	10.5	4.3	12C 12B 76B 63-4U 102 120		
BRS GM3L	H4221			M3	22.3	8.5	0.8	3.7	10.5				
BRS GM4S	H4222			M4	19.9	6.6	0.8	4.3	10.5				
BRS GM4L	H4223			M4	22.3	8.5	0.8	4.3	10.5				
BRS GM5S	H4225			BLUE	TO	M5	22.3	8.5	0.8			5.3	10.5
BRS GM5L	H4226			M5	22.3	9.5	0.8	5.3	10.5				
BRS GM6	H4227			16-14AWG	2.5	M6	27.3	12.0	0.8			6.4	10.5
BRS GM8	H4228			M8	27.3	12.0	0.8	8.4	10.5				
BRS GM10	H4229	M10	31.0	13.6	0.8	10.5	10.5						
YRSGM3	H4232	NO.3	2.5	M3	23.2	7.2	1.0	3.7	13.5	6.1	13B 76B 63-5U 102 120		
YRSGM4S	H4230			M4	23.2	7.2	1.0	4.3	13.5				
YRSGM4L	H4231			M4	27.1	9.5	1.0	4.3	13.5				
YRSGM5	H4233			M5	27.1	9.5	1.0	5.3	13.5				
YRSGM6	H4234			YELLOW	TO	M6	30.0	12.0	1.0			6.4	13.5
YRSGM8	H4237	12-10AWG	6.0	M8	34.5	15.0	1.0	8.4	13.5				
YRSGM10	H4238			M10	34.5	15.0	1.0	10.5	13.5				
YRSGM12	H4239			M12	39.1	19.2	1.0	13.0	13.5				

UNINSULATED FORK UTILUG



- Electro tinned to minimise corrosion
- Square sides provide a non-turn capability
- Suits terminal blocks

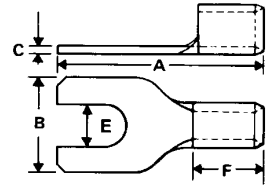

DESCRIPT.	CAT NO.	TERMINAL SIZE	CONDUCTOR AREA mm ²	STUD SIZE	DIMENSIONS mm					TOOL NO.
					A	B	C	E	F	
UF1.5M3	H4312	NO.1 12-16AWG	0.5	M3	16.0	6.4	0.7	3.7	4.8	00
UF1.5M4	H4314			M4	16.0	7.2	0.7	4.3	4.8	16
UF1.5M5S	H4315			M5	16.0	8.1	0.7	5.3	4.8	63-1
UF1.5M5L	H4317			M5	16.0	9.5	0.7	5.3	4.8	76B
UF2.5M3	H4321	NO.2 16-14AWG	1.5	M3	16.0	6.0	0.8	3.7	4.8	00
UF2.5M4	H4323			M4	16.0	7.2	0.8	4.3	4.8	18, 16
UF2.5M5L	H4326			M5	16.0	9.3	0.8	5.3	4.8	76B
UF6M3	H4332	NO.3 12-10AWG	2.5	M3	17.4	7.2	1.0	3.7	6.0	00
UF6M4	H4331			M4	18.5	9.0	1.0	4.3	6.0	16
UF6M5	H4333			M5	18.5	9.0	1.0	5.3	6.0	63-1
UF6M6	H4334			M6	24.5	12.0	1.0	6.4	6.0	18,76B, 124

4

SUPERGRIP FORK UTILUG



- Electro tinned to minimise corrosion
- Square sides provide a non-turn capability
- Suits terminal blocks

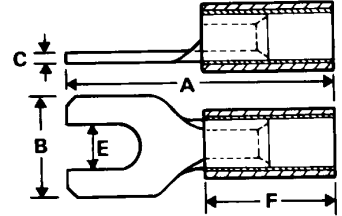

DESCRIPT.	CAT NO.	TERMINAL SIZE	CONDUCTOR AREA mm ²	STUD SIZE	DIMENSIONS mm					TOOL NO.
					A	B	C	E	F	
RFSGM3	H4512	NO.1 22-16AWG	0.5	M3	21.5	6.4	0.7	3.7	10.5	76B
RFSGM4	H4514			M4	21.5	7.2	0.7	4.3	10.5	11C or 11B
RFSGM5S	H4515			M5	21.5	8.1	0.7	5.3	10.5	63-4B
RFSGM5L	H4517	RED	1.5	M5	21.5	9.5	0.7	5.3	10.5	102, 120
BFSGM3	H4521	NO.2 16-14AWG	1.5	M3	21.5	5.7	0.8	3.2	10.5	76B
BFSGM4	H4523			M4	21.5	7.2	0.8	4.3	10.5	12C or 12B
BFSGM5S	H4525			M5	21.5	7.9	0.8	5.3	10.5	63-4U
BFSGM5L	H4526	BLUE	2.5	M5	21.5	9.3	0.8	5.3	10.5	102, 120
YFSGM3	H4532	NO.3 12-10AWG	2.5	M3	24.9	7.2	1.0	3.7	13.5	76B
YFSGM4	H4531			M4	26.0	9.0	1.0	4.3	13.5	13B
YFSGM5	H4533			M5	26.0	9.0	1.0	5.3	13.5	63-5U
YFSGM6	H4534	YELLOW	6.0	M6	32.0	12.0	1.0	6.4	13.5	102, 120

PRE-INSULATED FORK UTILUG



- Copper electro tinned to minimise corrosion
- Square sides provide a non-turn capability

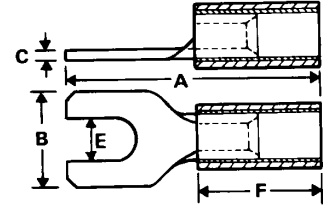

DESCRIPT.	CAT NO.	TERMINAL SIZE	CONDUCTOR AREA mm ²	STUD SIZE	DIMENSIONS mm					MAX. INSUL. DIA. mm	TOOL NO.
					A	B	C	E	F		
RFM3	H4412	NO.1	0.5	M3	21.0	6.4	0.7	3.7	10.0	3.5	9A
RFM4	H4414	RED	TO	M4	21.0	7.2	0.7	4.3	10.0		11C OR 11B
RFM5S	H4415	22-16AWG	1.5	M5	21.0	8.1	0.7	5.3	10.0		63-4B
RFM5L	H4417			M5	21.0	9.5	0.7	5.3	10.0		99, 102, 120
BFM3	H4421	NO.2	1.5	M3	21.0	6.0	0.8	3.7	10.0	4.3	9A
BFM4	H4423	BLUE	TO	M4	21.0	7.2	0.8	4.3	10.0		12C, 12B, 76B
BFM5S	H4425	16-14AWG	2.5	M5	21.0	7.9	0.8	5.3	10.0		63-4U
BFM5L	H4426			M5	21.0	9.3	0.8	5.3	10.0		99, 102, 120
YFM3	H4432	NO.3	2.5	M3	25.5	8.3	1.0	3.7	13.0	6.1	9A
YFM4	H4431	YELLOW	TO	M4	25.5	9.0	1.0	4.3	13.0		13B, 76
YFM5	H4433	12-10AWG	6.0	M5	25.5	9.0	1.0	5.3	13.0		63-4B
YFM6	H4434			M6	31.5	12.0	1.0	6.4	13.0		99, 102, 120



HIGH TEMPERATURE UTILUG RING TERMINAL

- Rated at 280°C
- Nickel plated

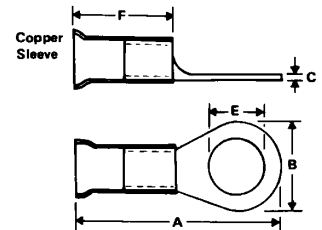

DESCRIPT.	CAT NO.	TERMINAL SIZE	CONDUCTOR AREA mm ²	STUD SIZE	DIMENSIONS mm					MAX. INSUL. DIA. mm	TOOL NO.
					A	B	C	E	F		
RHT1.5M5	H3215	NO.1 22-16AWG	0.5 TO 1.5	M5	19.2	7.9	0.7	7.9	9.0	3.6	76B, 16
RHT2.5M4	H3223	NO.2 16-14AWG	1.5 TO 2.5	M4	22.5	8.7	0.7	8.7	11.1	4.3	76B 16
RHT2.5M5	H3225			M5	22.5	8.7	0.7	8.7	11.1		
RHT2.5M6	H3227			M6	27.8	12.7	0.7	12.7	11.1		
RHT6M5	H3233	NO.3	2.5 TO	M5	24.4	9.5	0.9	9.5	12.7	6.1	16, 18, 76B, 124
RHT6M6	H3234	12-10AWG	6.0	M6	29.3	12.7	0.9	12.7	12.7		



HEAVY DUTY INSULATED RING TERMINAL

- Seamless drawn copper tube electro tinned,
- black nylon insulator • Palms radiused

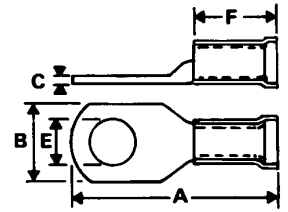

DESCRIPT.	CAT NO.	TERMINAL SIZE	CONDUCTOR AREA mm ²	STUD SIZE	A	DIMENSIONS mm				MAX. INSUL. DIA. mm	TOOL NO.
					B	C	E	F			
RHD0.5M5S	H2001S	0.5	1/0.80	M5	26.0	8.6	0.9	11.1	12.7	3.5	76B, 60, 28A
RHD0.5M5L	H2001L			M5	29.4	8.7	0.9	15.1	12.7		
RHD0.5M6	H2002	2.5	1/0.80	M6	30.0	10.3	0.8	15.1	12.7	4.3	76B, 60, 28A
RHD2.5M5	H2036			M5	26.2	9.0	1.0	11.9	12.7		
RHD2.5M6	H2037	4.0	1/0.80	M6	30.9	10.3	0.9	15.1	12.7	6.1	76B, 60, 28A, 124
RHD4M5S	H2003S			M5	28.9	8.7	1.5	11.1	14.0		
RHD4M5L	H2003L	6	7/1.04	M5	32.6	8.7	1.4	14.7	14.0	6.8	60, 124
RHD4M6	H2004			M6	32.0	10.0	1.2	15.1	14.0		
RHD6M6	H2005	10	7/1.35	M6	31.0	10.0	1.2	15.1	13.0	8.3	60, 124
RHD10M6	H2006			M6	31.8	11.9	1.8	15.1	13.0		

4

BOOTLACE FERRULES

CAT NO.	Nominal Conductor (mm ²)	DIMENSIONS					COLOUR	CRIMPING TOOL NO.
		L	F	D	W			
BLF05	0.5	12.0	6.0	1.3	2.6	White	#112 #125	
BLF07	0.75	12.3	6.0	1.5	2.8	Blue	#112 #125	
BLF1	1.0	12.3	6.0	1.7	3.3	Red	#112 #125	
BLF2	1.5	14.3	8.0	2.0	3.5	Black	#112 #125	
BLF3	2.5	15.4	8.0	2.6	4.0	Grey	#112 #125	
BLF4	4	16.4	9.0	3.2	4.5	Orange	#112 #125 #126	
BLF6	6	20.5	12.0	3.9	6.0	Green	#112 #121 #126	
BLF10	10	20.8	12.0	4.9	7.5	Brown	#112 #121 #126	
BLF16	16	22.2	12.0	6.2	8.7	Ivory	#121	
BLF25	25	28.0	16.0	7.9	11.0	Black	#121	
BLF35	35	30.0	16.0	8.7	12.5	Beige	#122	
BLF50	50	36.0	20.0	10.9	15.0	Olive	#122	
BLF70	70	37.0	20.0	14.3	16.0	Yellow	#38A	
BLF95	95	44.0	25.0	15.3	18.5	Red	#38A	
BLF120	120	47.6	27.0	17.5	20.3	Blue	#38A	

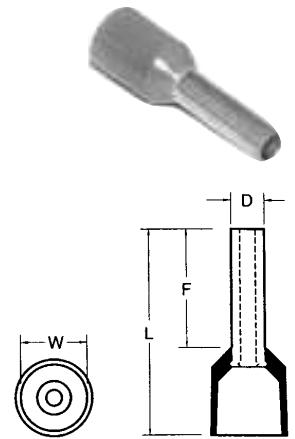

DUAL BOOTLACE FERRULES

CAT NO.	Nominal Conductor (mm ²)	DIMENSIONS					COLOUR	CRIMPING TOOL NO.
		L	F	D	W			
BLFT07	0.75	14.7	8.0	2.1	5.5	Grey	#112 #125	
BLFT1	1.0	15.1	8.0	2.3	5.5	Red	#112 #125	
BLFT2	1.5	15.5	8.0	2.6	6.4	Black	#112 #125	
BLFT3	2.5	18.5	10.0	3.3	8.0	Blue	#112 #125	
BLFT4	4	23.1	12.0	4.2	8.8	Grey	#112 #125	
BLFT6	6	26.1	14.0	5.3	9.5	Yellow	#112 #125	

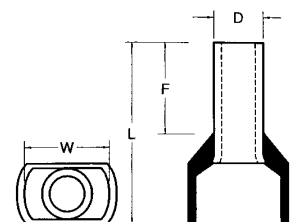

UNINSULATED CRIMP PIN CONNECTOR



- Electro tinned copper to minimise corrosion
- Sizes 1, 2, 3 circular pin • Sizes 4, 5 flat pin

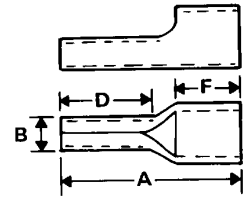

DESCRIPT.	CAT NO.	TERMINAL SIZE	CONDUCTOR AREA mm ²	DIMENSIONS mm				TOOL NO.
				A	B	D	F	
UP1.5	H2271	NO.1	0.5-1.5	15.9	1.6	9.5	5.2	76B, 00, 16B, 21
UP2.5	H2272	NO.2	1.5-2.5	17.4	2.0	10.3	5.5	76B, 00, 16B, 21
UP6	H2273	NO.3	2.5-6.0	20.6	2.8	11.9	6.6	76B, 00, 16B, 21

PRE-INSULATED PIN CONNECTOR



- Electro tinned copper to minimise corrosion
- PVC insulation • Circular pin

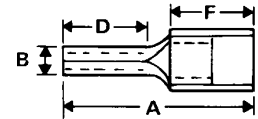

DESCRIPT.	CAT NO.	TERMINAL SIZE	CONDUCTOR AREA mm ²	DIMENSIONS mm				MAX. INSUL. DIA mm	TOOL NO.
				A	B	D	F		
RP	H2276	NO.1 Red	0.5-1.5	21.0	1.6	9.5	10.3	3.3	76B, 11C, 11B, 99, 102, 120
BP	H2278	NO.2 Blue	1.5-2.5	23.8	2.0	10.3	11.9	4.3	76B, 12C, 12B, 99, 102, 120
YP	H2280	NO.3 Yellow	2.5-6.0	27.5	2.8	11.9	13.5	6.1	76B, 13B, 99, 102, 120

SUPERGRIP PIN CONNECTOR

- Electro tinned copper to minimise corrosion • Circular pin
- Fitted with a copper ferrule and pre-insulated for secure insulation support

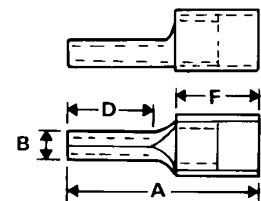
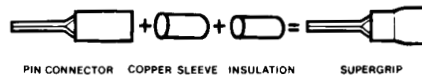

DESCRIPT.	CAT NO.	TERMINAL SIZE	CONDUCTOR AREA mm ²	DIMENSIONS mm				MAX. INSUL. DIA mm	TOOL NO.
				A	B	D	F		
MYPSG	H3556	NO.0 Yellow	0.2-0.5	18.3	1.2	10.0	8.3	2.2	78
RPSG	H2286	NO.1 Red	0.5-1.5	21.0	1.6	9.5	10.3	3.5	76B, 11C, 11B, 99, 102, 120
BPSG	H2287	NO.2 Blue	1.2-2.5	23.8	2.0	10.3	11.9	4.3	76B, 12C, 12B, 99, 102, 120
YPSG	H2288	NO.3 Yellow	2.5-6.0	27.5	2.8	11.9	13.5	6.1	76B, 13B, 99, 102, 120

PRE-INSULATED AND SUPERGRIP CRIMP LINK CABLE CONNECTOR

- Solid drawn copper tube • Electro tinned to minimise corrosion
- Centre dimple to ensure correct conductor traverse inside link • Vinyl insulation

STYLE 1. Parallel splice conductor area shown is total of two (or more) conductors to be connected parallel.

Ideal for inline joints between uneven sized conductor – vinyl insulation.

STYLE 2. Centre dimple to ensure correct conductor positions – vinyl insulation.

STYLE 3. Supergrip butt splice with translucent insulation (to ensure correct conductor insertion) and depressed centre to enable use in appropriate ratchet crimp tool without removal of stopper.



STYLE 1.



STYLE 2.

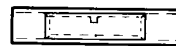

STYLE 3.



Translucent insulation Link Super Grip Ferrules

DESCRIPT.	CAT NO.	INSULATION	CONDUCTOR AREA mm ²	STYLE	DIMENSIONS A mm	MAX. INSUL. DIA. mm	TOOL NO.
RL	H2068	Red	0.5-1.5	1	15.9	3.2	76B, 11C, 11B, 63-4B, 102, 120
BL	H2069	Blue	1.5-2.5	1	7.9	4.0	76B, 12C, 12B, 63-4U, 102, 120
YL	H2070	Yellow	2.5-6.0	1	20.4	5.5	76B, 13B, 63-5U, 102, 120
RLD	H2071	Red	0.5-1.5	2	22.2	3.2	76B, 11C, 11B, 63-4B, 102, 120
BLD	H2072	Blue	1.5-2.5	2	25.4	4.0	76B, 12C, 12B, 63-4U, 102, 120
YLD	H2073	Yellow	2.5-6.0	2	27.0	5.5	76B, 13B, 63-5U, 102, 120
RLSG	H3910	Red	0.5-1.5	3	31.0	4.0	76B, 11C, 11B, 63-4B, 102, 120
BLSG	H3911	Blue	1.5-2.5	3	31.0	4.6	76B, 12C, 12B, 63-4U, 102, 120
YLSG	H3912	Yellow	2.5-6.0	3	41.0	6.2	76B, 13B, 63-5U, 102, 120

4



CLOSED END PRE-INSULATED CABLE CONNECTOR

- Electro tinned to minimise corrosion
- Nylon insulation to maximise dielectric strength

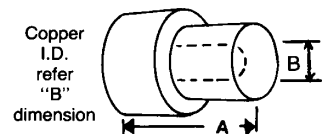

DESCRIPT.	CAT NO.	STRANDING METRIC	I.D. mm B	DIMENSIONS A mm	TOOL NO.
CEC1	H349	2X24/0.20	2.08	15.1	76B, 11A, 11B
CEC2	H2023	2X24/0.20	3.3	21	28A
CEC5	H2026	2X50/0.25	4.5	27	28A
CEC1.5	H2047	2X32/0.20	2.5	15.2	76B, 11C, 11B
CEC2.5	H2048	2X32/0.20	3.7	18	76B, 13B
CEC4	H2050	2X32/0.20	3.35	19.1	76B, 13B
CEC8	H2049	5X32/0.20	5.0	30	76B

HEAVY DUTY PRE-INSULATED CRIMP LINK CONNECTOR



- Seamless drawn copper tube
- Black nylon insulated
- Centre dimple to help locate the conductor
- Electro tinned to minimise corrosion

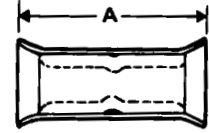

DESCRIPT.	CAT NO.	CONDUCTOR AREA mm ²	STRANDING METRIC	DIMENSIONS A mm	MAX. INSUL. DIA. mm	TOOL NO.
LHD2.5S	H2051	CE2X24/0.2	1/0.80-7/0.67	30.1	4.7	28, 76B
LHD2.5	H2067	CE2X24/0.2	7/0.67	30.1	4.7	28, 76B
LHD4	H2052	CE2X24/0.2	7/0.67-7/0.85	32.3	6.4	28, 76B
LHD6	H2053	CE2X24/0.2	7/1.04	29.0	8.3	28
LHD10	H2054	CE2X24/0.2	7/1.35	29.0	8.3	76B, 13B



2.8mm Q.C. RECEPTACLE

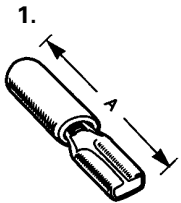

DESCRIPT.	CAT NO.	ILLUS. NO.	MATERIAL	THICKNESS	FINISH	LENGTH A mm	MAX. INSUL. DIA. mm	WIRE SIZE mm ²	NOTES
RQCSG2.8/0.8	H3558	1	Brass/PVC	0.25	ET	17.9	3.2	0.5-1.5	Red to suit 0.8 Tab
RQCSG2.8/0.5	H3564	1	Brass/PVC	0.25	ET	17.9	3.2	0.5-1.5	Red to suit 0.5 Tab

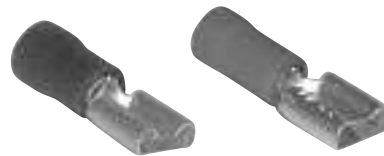

4.8mm Q.C. RECEPTACLES to suit 0.5mm tabs

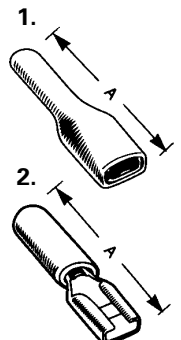

DESCRIPT.	CAT NO.	ILLUS. NO.	MATERIAL	THICKNESS	FINISH	LENGTH A mm	MAX. INSUL. DIA. mm	WIRE SIZE mm ²	NOTES
RQCSG4.8	H3559	1	Brass/PVC	0.40	ET	18.7	3.2	0.5-1.5	Red
RQCSG4.8F	H3563	2	Brass/PVC	0.35	ET	20.0	2.7	0.5-1.5	Red
BQCSG4.8	H3565	1	Brass/PVC	0.40	ET	18.7	4.0	1.5-2.5	Blue
BQCSG4.8F	H3566	2	Brass/PVC	0.35	ET	20.0	3.2	1.5-2.5	Blue

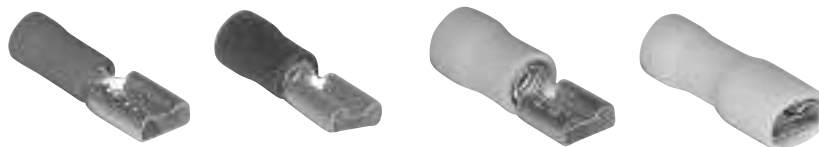

6.3mm Q.C. RECEPTACLES to suit 0.8mm tabs

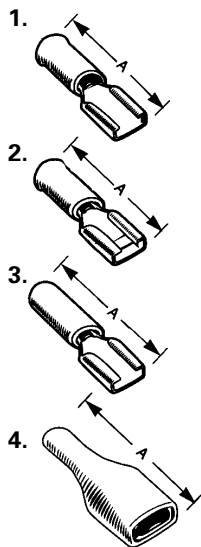

DESCRIPT.	CAT NO.	ILLUS. NO.	MATERIAL	THICKNESS	FINISH	LENGTH A mm	MAX. INSUL. DIA. mm	WIRE SIZE mm ²	NOTES
RQCSG6.3	H2594A	2	Brass/PVC	0.40	ET	20.5	3.5	0.5-1.5	Red
BQCSG6.3	H2595A	2	Brass/PVC	0.40	ET	20.5	4.3	1.5-2.5	Blue
YQCSG6.3	H2596A	2	Brass/PVC	0.40	ET	24.6	4.3	2.5-6.0	Yellow
RQCSG6.3L	H2594	1	Brass/PVC	0.40	ET	22.2	3.5	0.5-1.5	Red
BQCSG6.3L	H2595	1	Brass/PVC	0.40	ET	23.8	4.3	1.5-2.5	Blue
YQCSG6.3L	H2596	1	Brass/PVC	0.70	ET	25.4	6.0	2.5-6.0	Yellow
RQCSG6.3F	H3560	4	Brass/PVC	0.70	ET	22.0	2.7	0.5-1.5	Red
BQCSG6.3F	H3561	4	Brass/PVC	0.70	ET	22.0	3.2	1.5-2.5	Blue
YQCSG6.3F	H3562	4	Brass/PVC	0.70	ET	25.0	3.8	2.5-6.0	Yellow



6.3mm Q.C. TABS

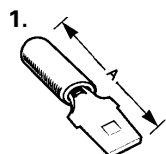

DESCRIPT.	CAT NO.	ILLUS. NO.	MATERIAL	THICKNESS	FINISH	LENGTH A mm	MAX. INSUL. DIA. mm	WIRE SIZE mm ²	NOTES
RTSG6.3	H2844	1	Brass/PVC	0.80	ET	23.2	3.5	0.5-1.5	Red
BTSG6.3	H2845	1	Brass/PVC	0.85	ET	24.8	4.3	1.5-2.5	Blue
YTSG6.3	H2846	1	Brass/PVC	0.80	ET	26.3	6.0	2.5-6.0	Yellow



6.3mm ADAPTORS Q.C. PIGGY BACK

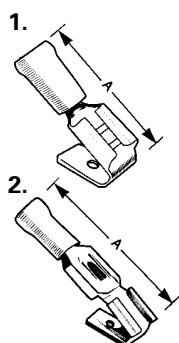

DESCRIPT.	CAT NO.	ILLUS. NO.	MATERIAL	THICKNESS	FINISH	LENGTH A mm	MAX. INSUL. DIA. mm	WIRE SIZE mm ²	NOTES
RPBSG6.3	H2847A	1	Brass/PVC	0.80	ET	22.2	3.5	0.5-1.5	Red
BPBSG6.3	H2848A	1	Brass/PVC	0.85	ET	22.2	4.3	1.5-2.5	Blue
YPBSG6.3	H2849	2	Brass/PVC	0.80	ET	33.4	6.0	2.5-6.0	Yellow



9.3mm Q.C. RECEPTACLES

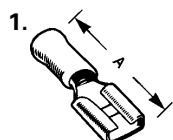

DESCRIPT.	CAT NO.	ILLUS. NO.	MATERIAL	THICKNESS	FINISH	LENGTH A mm	MAX. INSUL. DIA. mm	WIRE SIZE mm ²	NOTES
YQC9.3	H2853A	1	Brass/PVC	-	ET	29.2	6.2	2.5-6.0	Yellow

LIP BLADE TERMINALS

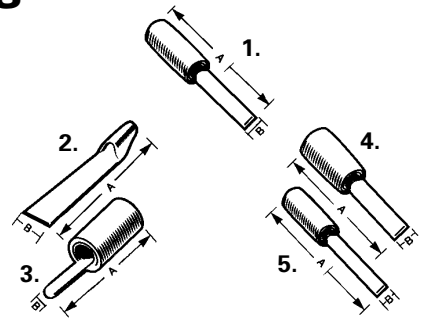

DESCRIPT.	CAT NO.	ILLUS. NO.	MATERIAL	THICKNESS	FINISH	LENGTH A mm	WIDTH B mm	MAX. INSUL. DIA. mm	WIRE SIZE mm ²	NOTES
RLB	H2736	1	Copper	0.7	ET	24.8	2.9	3.5	0.5-1.5	Red
BLB	H2737	1	Copper	0.7	ET	26.8	3.0	3.7	1.5-2.5	Blue
RLBSG	H2736A	1	Copper	0.8	ET	27.7	3.0	3.5	0.5-1.5	Red
BLBSG	H2737A	1	Copper	0.8	ET	27.7	3.0	4.1	1.5-2.5	Blue
YLSBG	H2738A	1	Copper	1.0	ET	30.7	3.0	4.1	1.5-2.5	Yellow
RLLBSG	H3916A	3	Copper	0.7	ET	17.2	3.0	3.5	0.25-1.5	Lipless Miniature Blade
BLLBSG	H3917A	3	Copper	0.7	ET	18.0	2.7	4.3	0.6-3.0	Lipless Miniature Blade
YLLBSG	H3918A	3	Copper	0.9	ET	22.4	2.7	6.3	2.5-6.0	Lipless Miniature Blade
RLLBSGL	H4107A	4	Copper	0.8	ET	28.5	2.0	3.5	0.5-1.5	Lipless Long Blade
BLLBSGL	H4108A	4	Copper	0.8	ET	28.5	2.0	4.3	1.5-2.5	Lipless Long Blade
RLBW	H4107	4	Copper	0.8	ET	25.8	4.6	3.5	0.5-1.5	Red
BLBW	H4108	4	Copper	0.8	ET	25.8	4.6	4.3	1.5-2.5	Blue
YLBW	H4109	4	Copper	0.8	ET	30.3	4.6	6.3	2.5-6.0	Yellow
RLBSGW	H4207	5	Copper	0.8	ET	26.4	4.6	3.5	0.5-1.5	Red Supergrip
BLBSGW	H4208	5	Copper	0.8	ET	26.4	4.6	4.3	1.5-2.5	Blue Supergrip
YLSBGW	H4209	5	Copper	0.8	ET	30.8	4.6	6.3	2.5-6.0	Yellow Supergrip



BULLET TERMINAL

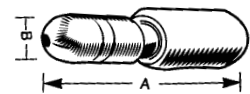

DESCRIPT.	CAT NO.	MATERIAL	FINISH	LENGTH A mm	LENGTH B mm	MAX. INSUL. DIA. mm	WIRE SIZE mm ²	NOTES
RBSG	H3919	Brass/PVC	ET	20.2	4.0	3.5	0.5-1.5	Mates with H3922
BBSG	H3920	Brass/PVC	ET	20.7	5.0	4.3	1.5-2.5	Mates with H3923



BULLET RECEPTACLE

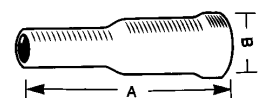

DESCRIPT.	CAT NO.	MATERIAL	FINISH	LENGTH A mm	LENGTH B mm	MAX. INSUL. DIA. mm	WIRE SIZE mm ²	NOTES
RBRSG	H3922	Brass/PVC	ET	24.0	4.0	2.7	0.5-1.5	Mates with H3919
BBSG	H3923	Brass/PVC	ET	25.0	5.0	3.2	1.5-2.5	Mates with H3920



LOOSE PIECE BRASS CONNECTORS

DESCRIPT.	MATERIAL	THICKNESS	LENGTH A mm	MAX. INSUL. DIA. mm	WIRE SIZE mm ²	HAND TOOLS	NOTES
BULLET RECEPTACLES							
H2743	Brass	0.45	17	3.3	0.7-2.1	#17, #61	mates with H2782
BULLET TERMINALS							
H2782	Brass	0.45	17	3.3	0.75-1.5	#17, #61	mates with H2743
6.3mm Q.C. RECEPTACLES							
H1972	Brass	0.45	19.8	2.8	0.7-2.1	#17, #61, #95	
H2833B	Nick/Silv	0.4	19.6	3.9	1.0-1.5	#17, #61, #95	Piggy Back
LANCED TAB							
H2832	Brass			3	0.7-2.1		
6.3mm Q.C. RECEPTACLES CRIMP TYPE							
H1192	Brass	0.08/.04	19.8	3.7	0.7-2.1	#17, #61, #95	
H1192B	Nick/Silv	0.8/0.4	19.8	3.7	0.7-2.1	#17, #61, #95	
LANCED Q.C. FOR LANCED CONNECTORS							
H3555	Brass	0.3	19.8	3.9	0.6-1.5	#17	
4.8mm Q.C. RECEPTACLES							
H1143	Brass	0.3	15.4	3.3	0.4-1.5	#61, #94	high temp
H2590B	Nick/Silv	0.4	15.4	3.3	0.4-1.5	#61, #94	high temp
FLAG TYPE TO SUIT 0.5mm TAB							
H1145	Brass	0.4	12.6	3.3	0.4-1.5	#147	
FLAG TYPE							
H1191B	Nick/Silv	0.45	15.1	3.3	0.7-2.1	#14	Housing H2818, H2819
4.8mm FLAG TYPE TO SUIT 0.5mm TAB							
H1145B	Nick/Silv	0.4	12.6	3.3	0.4-1.0	#147	
EYE TERMINAL TO SUIT 5mm STUD							
H430	Brass	0.55	21.4	3.9	0.5-2.5	#17, #61	hole, slot, screw 5.3
H430B	Brass	0.55	21.4	3.9	0.5-2.5	#17, #61	hole, slot, screw 5.3

TK22 ELECTRICAL TERMINAL KIT

- 1405 mixed supergrip terminals for 240V/415V applications
- Quality ratchet crimping tool (#102) • Tough metal carry case.



CONTENTS:

CAT. NO.	DESCRIPTION	QTY
H2594A	6.3mm QC Receptacle Red	50
H2595	6.3mm QC Receptacle Blue	100
H2596A	6.3mm QC Receptacle Yellow	50
H2844	6.3mm QC Tab Red	50
H2845	6.3mm QC Tab Blue	100
H2848	6.3mm QC Piggy Back Adaptor	50
H3560	6.3mm QC Receptacle Red	50
H3561	6.3mm QC Receptacle Blue	50
H3562	6.3mm QC Receptacle Yellow	40
H3563	4.8mm QC Receptacle Red	50
H3910	Window Crimp Link Red	50
H3911	Window Crimp Link Blue	50
H3912	Window Crimp Link Yellow	25
H4213	4.3mm Supergrip Ring Terminal Red	100
H4215	5.3mm Supergrip Ring Terminal Red	100
H4218	6.4mm Supergrip Ring Terminal Red	80
H4223	4.3mm Supergrip Ring Terminal Blue	100
H4225	5.3mm Supergrip Ring Terminal Blue	70
H4234	6.4mm Supergrip Ring Terminal Yellow	40
H4523	4.3mm Supergrip Fork Terminal Blue	100
H4514	4.0mm Spade Connector	100
#102	Crimping Tool	1

CONTENTS

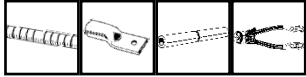

OVERHEAD SLEEVES AND LUGS

SECTION 5

SECTION 5	OVERHEAD CONDUCTOR SLEEVES & LUGS45
	NON TENSION SLEEVES46
	FULL TENSION SLEEVES – TYPE A46
	FULL TENSION SLEEVES – TYPE R47
	JUMPER SPLICE SLEEVE47
	TERMINAL LUGS – TYPE AL48
	TERMINAL LUGS – TYPE SL48
	ELECTRICAL JOINTING COMPOUND48
	CONNECTORS FOR STRANDED COPPER CONDUCTORS – IMPERIAL & METRIC49
	#TY SERIES CRIMPING TOOL50
	#TR SERIES CRIMPING TOOL50
	#38A HYDRAULIC CRIMPING TOOL50

NON TENSION SLEEVES

- Tubular aluminium alloy
- Pre-packed with jointing compound
 - Individually packed in sealed plastic bags
- Suitable for overhead and underground joints in industrial and commercial installation
- **Suitable for AAC, AAAC and ACSR conductors**
 - Use hexagonal or indent type of crimps
 - Centre barrier included

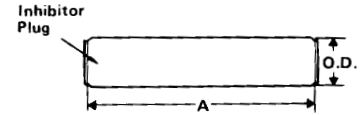

CAT NO.	CONDUCTOR RANGE O.D. mm	LENGTH A mm	NOMINAL O.D.	UC6 VERSA
NT36	6-8	59	16.5	2
NT44	8-10	70	20.6	2
NT50	10-12	84	20.6	3
NT58	12-13.5	111	22.2	3
NT61	13-14.5	111	25.4	3
NT68	14-16	146	25.4	4
NT80	16.5-19.5	146	30.1	5
NT94	20-23.5	155	35	-
NT114	24.5-26.25	185	50	-

Refer Appendix A (Section 10/Page 109) for full list of cables and applicable product and crimp dies.

FULL TENSION SLEEVES - TYPE A

- Tubular aluminium alloy
- Pre-packed with jointing compound
 - Individually packed in sealed plastic bags
- Use hexagonal or indent type of crimps
 - Designed for full tension splices of overhead transmission lines
- **Suits all aluminium conductors (AAC)**
 - Centre barrier included

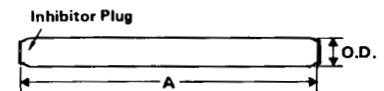

CAT NO.	CONDUCTOR RANGE O.D. mm	LENGTH A mm	NOMINAL O.D.
FT36A	6-8	165	16.5
FT44A	8-10	165	20.6
FT50A	10-12	203	20.6
FT58A	12-13.5	203	22.2
FT61A	13-14.5	241	25.4
FT68A	14-16	279	25.4
FT80A	16.5-19.5	318	30.1
FT94A	20-21.75	387	35
FT114A	24.5-26.25	710	50

Refer Appendix A (Section 10/Page 109) for full list of cables and applicable product and crimp dies.

FULL TENSION SLEEVES – TYPE R

- Designed for full tension splices of overhead transmission lines
- **Suit conventional or smooth body conductors, ACSR, all aluminium and all aluminium alloy conductors**
 - Centre barrier included
 - Remove excess grease from steel core of ACSR cables
 - Do not use solvent
 - Conductor range O.D. measurements nominated have been determined on the basis of high ratio aluminium/steel conductor configuration
 - For high ratio steel/aluminium conductors refer to Utilux for recommendation

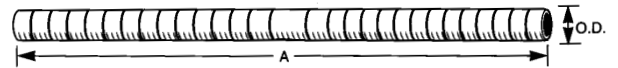

CAT NO.	CONDUCTOR RANGE O.D. mm	LENGTH A mm	NOMINAL O.D.
FT36R	6-8	344	16.5
FT44R	8-10	379	20.6
FT50R	10-12	470	20.6
FT61R	13-14.5	505	25.4
FT68R	14-16	530	25.4

Refer Appendix A (Section 10/Page 109) for full list of cables and applicable product and crimp dies.

5

JUMPER SPLICE SLEEVE

- Tubular aluminium alloy fittings
- Pre-packed with jointing compound
- Individually packed in sealed plastic bags
- Suitable for overhead non-tension jumpers in commercial and industrial installations
- **Suitable for AAC, AAAC, ACSR and copper conductor**
 - Use hexagonal or ident type of crimps
 - Centre barrier included

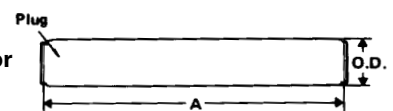

CAT NO.	CONDUCTOR RANGE O.D. mm	CRIMPS PER END		LENGTH A mm	NOMINAL O.D.
		SERIES 5	SERIES 6		
+JS36R	6-8	4	2	127	16.5
JS44R	8-10	4	2	165	20.6
JS50R	10-12	6	3	165	20.6
+JS58R	12-13.5	8	4	205	22.2
+JS61R	13-14.5	–	4	205	25.4
JS68R	14-16	–	4	205	25.4
JS80R	16.5-19.5	–	4	205	30.1
JS94R	20-23.5	–	–	205	35

Refer Appendix A (Section 10/Page 109) for full list of cables and applicable product and crimp dies.

† Made to approved order quantities only.



TERMINAL LUGS – TYPE AL

- Extruded aluminium tube
- Pre-filled with jointing compound
- Individually packed in plastic bags
- Designed for compression by hexagonal or indent type tools
- Available also with blank palms

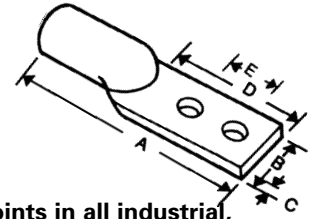

- ACSR, AAAC and AAC conventional and smooth body
- Suitable for non tension joints in all industrial, overhead transmission application
- Two hole connection ensure stability

CAT NO.	CONDUCTOR RANGE O.D.	IMP. STUD SIZE	DIMENSIONS mm				HOLE CTS.E
			A	B	C	D	
AL36	6-8	0.5	129	25	6	82.5	44.5
AL44	8-10	0.5	136.5	27.3	8.8	82.5	44.5
AL50	10-12	0.5	136.5	27.8	7.9	82.5	44.5
AL58	12-13.5	0.5	146.0	31.7	7.5	82.5	44.5
AL61	13-14.5	0.5	149.0	34.9	9.9	82.5	44.5
AL68	14-16	0.5	176.0	34.9	9.9	82.5	44.5
AL80	16.5-19.5	0.5	169.9	41.3	9.9	82.5	44.5
AL94	20-23.5	0.5	176.0	34.9	9.9	82.5	44.5

Refer Appendix A (Section 10/Page 109) for full list of cables and applicable product and crimp dies.



TERMINAL LUGS – TYPE SL

- Extruded aluminium tube
- Pre-filled with jointing compound
- Individually packed in plastic bags
- Designed for compression by hexagonal or indent type tools
- Available also with blank palms

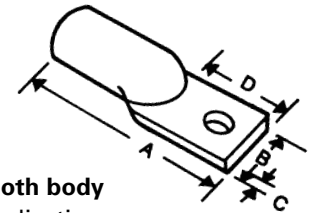

- Recommended conductor ACSR, AAAC or AAC – conventional and smooth body
- Suitable for non tension joints in all industrial, overhead transmission applications

CAT NO.	CONDUCTOR RANGE O.D.	IMP. STUD SIZE	DIMENSIONS mm			
			A	B	C	D
SL36	6-8	0.5	81.0	22.2	7.4	38.1
SL44	8-10	0.375	90.0	27.0	9.0	38.1
SL50	10-12	0.5	92.1	27.8	7.9	38.1
SL58	12-13.5	0.5	101.6	31.8	7.5	38.1
SL61	13-14.5	0.5	104.8	34.9	9.9	38.1
SL68	14-16	0.5	131.5	34.9	8.4	38.1
SL80	16.5-19.5	0.5	125.4	41.3	9.9	38.1

Refer Appendix A (Section 10/Page 109) for full list of cables and applicable product and crimp dies.
Made to minimum order only



ELECTRICAL JOINTING COMPOUND

- Recommended whenever aluminium is part of a connection
- H2397 with zinc particles suspended in a no melt grease penetrates the oxide film on aluminium surfaces and provides low initial contact resistance
 - The compound in the joint seals out air and moisture preventing oxidation or corrosion and ensures high conductivity

CAT NO.	NO.	APPLICATION	PART	COLOUR	TUBE SIZE
H2397	4C	Conductive compound with zinc particles	Zn	KD Grey	325g

CONNECTORS FOR STRANDED COPPER CONDUCTORS - IMPERIAL & METRIC

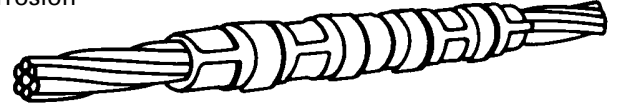

- Connector Material – copper, metal sprayed internally • Superior tensile strength
• Considerable reduction in mass of finished joint
• Elimination of corrosion

IMPERIAL

CAT NO.	STRANDING IMPERIAL	CONNECTOR DIMENSIONS		CRIMP GROOVE SIZE mm	REC. TOOL TYPE	CRIMPS PER CONNECTOR
		O.D. mm	LENGTH mm			
TDCS1	7/.044	6.35	38	6.35	#TY	4
TDCS2	7/.048	6.35	38	6.35	#TY	4
TECS1	7/.052	7.94	64	7.94	#TY	8
TECS2	7/.064	7.94	64	7.94	#TY	8
TFCS1	7/.080	9.52	76	9.52	#TR	8
TFCS2	19/.052	9.52	76	9.52	#TR	8
TFCS3	7/.083	9.52	76	9.52	#TR	8
TFCS4	7/.092	9.52	76	9.52	#TR	8
TGCS1	7/.097	12.70	89	12.70	#TR	10
TGCS2	7/.104	12.70	89	12.70	#TR	10
TGCS3	19/.064	12.70	89	12.70	#TR	10
THCS1	7/.136	15.88	127	15.88	#TR	14
THCS2	19/.083	15.88	127	15.88	#TR	14
TJCS1	19/.101	22.22	203	19.25	38-193CU	8
TJCS2	37/.072	22.22	203	19.25	38-193CU	8
TKCS1	19/.116	25.40	229	22.00	38-220CU	10
TKCS2	37/.083	25.40	254	22.00	38-220CU	12
TKCS3	37/.093	25.40	254	22.00	38-220CU	12
TMCS1	37/.103	28.57	305	24.74	38-247CU	14

METRIC

CAT NO.	STRANDING METRIC	CONNECTOR DIMENSIONS		CRIMP GROOVE SIZE mm	REC. TOOL TYPE	CRIMPS PER CONNECTOR
		O.D. mm	LENGTH mm			
TDCSM1	7/1.00	6.35	38	6.35	#TY	4
TDCSM2	7/1.04	6.35	38	6.35	#TY	4
TDCSM3	7/1.25	6.35	38	6.35	#TY	4
TECSM1	7/1.35	7.94	64	7.94	#TY	8
TECSM2	7/1.70	7.94	64	7.94	#TY	8
TECSM3	7/1.75	7.94	76	7.94	#T7	8
TFCSM1	7/2.14	9.52	76	9.52	#TR	8
TFCSM2	19/1.35	9.52	76	9.52	#TR	8
TGCSM1	7/2.75	12.70	89	12.70	#TR	10
TGCSM2	19/1.53	12.70	89	12.70	#TR	10
TGCSM3	19/1.70	8.50	89	12.70	#TR	10
THCSM1	7/3.50	15.88	127	15.88	#TR	14
THCSM2	19/1.78	15.88	127	15.88	#TR	14
THCSM3	19/2.14	15.88	127	15.88	#TR	14
TJCSM2	19/2.70	22.22	203	-	38-193CU	8

#TY SERIES CRIMPING TOOL

LENGTH 381mm • WEIGHT 1.16kg

Available in various crimp groove size combinations. The complete range is adjustable and robust. All models are supplied complete with adjusting key and GO-No Go gauge to ensure a perfect crimp every time.



CAT NO.	CRIMP GROOVE SIZES mm
#TY476556	4.76 and 5.56
#TY476635	4.76 and 6.35
#TY556635	5.56 and 6.35
#TY635794	6.35 and 7.94

#TR SERIES CRIMPING TOOL

LENGTH 534mm • WEIGHT 2.7kg

This Crimping Tool is available in various crimp groove size combinations. The complete range is adjustable and robust. All models are supplied complete with adjusting key and Go-No Go gauge to ensure a perfect crimp every time.



CAT NO.	CRIMP GROOVE SIZES mm
#TR9521270	9.52 and 12.70
#TR794952	7.94 and 9.52
#TR1588	15.88 (single groove)

#38A HYDRAULIC CRIMPING TOOL

LENGTH 580mm • WEIGHT 5.8g

Designed to accept hexagonal, circular and indent dies for applying compression connectors. The compression head will rotate through 180° arc. The body and handles of the tool are neoprene covered to provide mechanical protection.



SLEEVE	DIE NO.
#TD	38-44CU
#TE	38-63CU
#TF	38-77CU
#TG	38-104CU
#TH	38-130CU
#TJ	38-193CU
#TK	38-220CU
#TM	38-247CU

CONTENTS

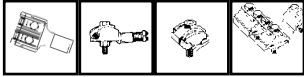

BOLTED OVERHEAD CONNECTORS

SECTION 6

SECTION 6	BOLTED OVERHEAD CONNECTORS51
	GENERAL PURPOSE	
	OVERHEAD LINE TAP CONNECTOR52
	DISCONNECT TEE CLAMP52
	SERVICE CONNECTOR53
	LINE STIRRUP CLAMP53
	ELECTRICAL JOINTING COMPOUND53
	PARALLEL GROOVE CONNECTORS54
	BI-METAL PG CLAMPS –	
	DOUBLE & TRIPLE BOLT54
	ALUMINIUM PG CLAMPS – DOUBLE BOLT55
	COPPER PG CLAMPS – SINGLE BOLT55
	COPPER PG CLAMPS – DOUBLE BOLT55
	SPLIT BOLT CONNECTORS56

GENERAL PURPOSE OVERHEAD LINE TAP CONNECTOR

- General purpose for bare overhead conductors applications where tap is required to carry full line current
 - Combined bolted and compression connection technology
 - Special aluminium alloy body for strength and ductility
 - Integral belleville washers • Stainless Steel fasteners
- Captive nut • Contact Surfaces pre-coated with Utilux No.3G jointing compound

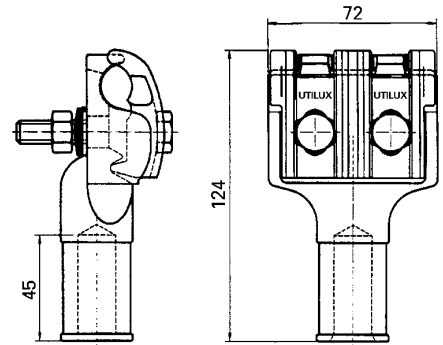

CAT NO.	DESCRIPTION	LINE CONDUCTOR RANGE (COND. OD)	Ø I.D. (XXY)
LTGSXXY	Line Tap Connector	6-19mm	Bore dimension Ø ID eg. for a bore of 17.5mm, xxy = 175

DISCONNECT TEE CLAMP

- All aluminium • Accepts Aluminium single hole crimp lugs

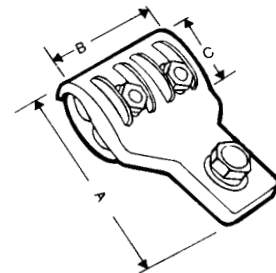

CAT NO.	CONDUCTOR RANGE O.D.	DIMENSIONS mm			BOLT DIA.	SET SCREW
		A	B	C		
TCDA19	7-19	120.0	75.0	42.0	M10 x 50	M12 X 40

Made to minimum order only

SERVICE CONNECTOR

- Cast high strength aluminium alloy connector identified with Catalogue No. and cable range
- Available in two configurations

TYPE 1. Tinned split bolt clamp compression crimped into connector body for direct service connection

TYPE 2. Two connectors joined by a customer nominated length of tinned 7/.104 (imperial) copper conductor (Standard is 254mm) • Available with stainless steel hardware on application

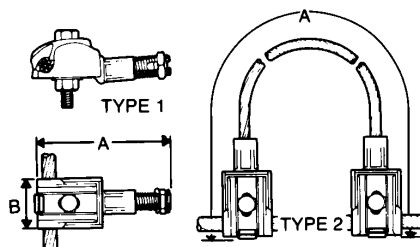

BT SERIES	CAT NO.		CONDUCTOR RANGE O.D.		DIMENSIONS mm		BOLT DIA
	BT-PP SERIES		MAIN	TAP	A	B	
*BT2-1	BT2-1PP		15	6	111.1	40.5	M10 X 50
BT2-2	BT2-2PP		15	-	412.8	40.5	M10 X 50

*Accepts 6mm OD cable from 1 to 3 times
BT-PP series contain grease

LINE STIRRUP CLAMP

- Cast high strength aluminium alloy, heat treated
 - Individually packed in plastic bags and identified with Catalogue No. and cable range
 - Tinned stranded copper stirrup is compression crimped into the connector body
 - Incorporates anodised aluminium nuts and bolts
 - Bolts are located in retaining channels to prevent slip during installation
 - Features the combination of a parallel groove clamp and a line stirrup clamp, enabling copper taps to be made at bridging locations.
- Application – connection of copper conductors to aluminium mains
- LS-PP Series pre-packed with jointing compound
 - LS-PPSS Series pre-packed with jointing compound and with Stainless Steel hardware

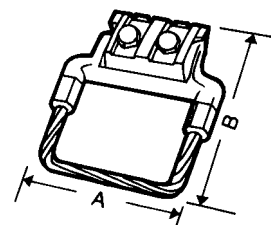
6

LS SERIES	CAT NO.		CONDUCTOR RANGE O.D. MAIN AL OR ACSR	DIMENSIONS mm		BOLT DIA
	LS-PP SERIES	LS-PPSS SERIES		A	B	
LS01	LS01PP	LS01PPSS	6-19	76.2	146.1	M10 x 50
LS02	LS02PP	LS02PPSS	6-19	120.7	146.1	M10 x 50



ELECTRICAL JOINTING COMPOUND

- Seals out air and moisture, therefore minimising oxidation or corrosion and maximising conductivity
- High melt point grease

CAT NO.	NO.	APPLICATION	PART	COLOUR	TUBE SIZE
H2398	1	For bolted palm connections	No Grit	Light Brown (honey colour)	250g

PARALLEL GROOVE CONNECTORS

- Cast high strength aluminium alloy, heat treated
- Individually packed in plastic bags and identified with Catalogue No. and cable range
- Anodised aluminium nuts and bolts of sufficient length to allow installation without disassembling connector
 - Bolts are located in retaining channels to prevent slip during installation
 - Suitable for the following conductors: ACSR, AAC – conventional or smooth body
- Designed specifically for overhead power line applications
 - PG-PP Series pre-packed with jointing compound
 - Stainless steel, electro-tinned or galvanised bolts available for approved minimum order quantities

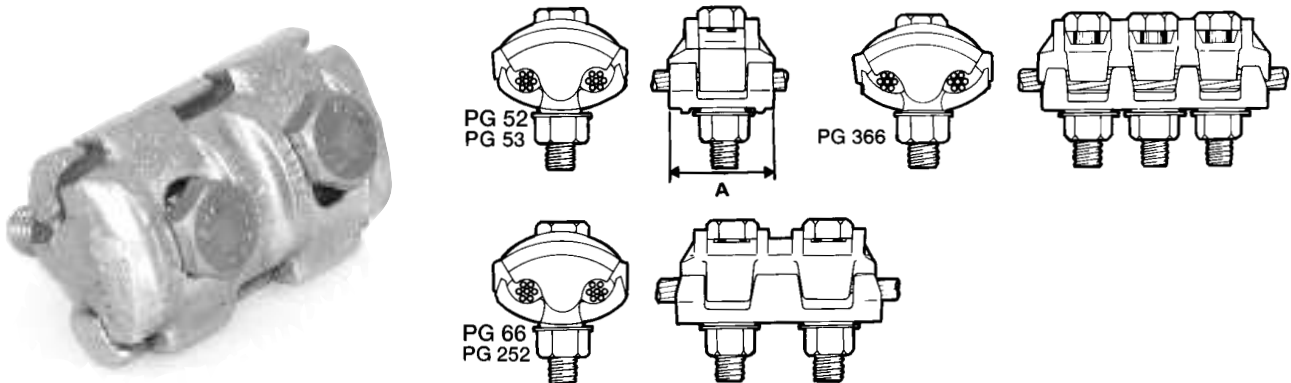

PG SERIES	CAT NO. PG-PP SERIES	NO. BOLTS	CONDUCTOR O.D.		LENGTH A mm	BOLT
			MAIN (MAX O.D.)	TAP (MIN O.D.)		
PG52	PG52PP	1	12	3	37	M10 x 50
PG53	PG53PP	1	19	9	55	M12 x 65
PG66	PG66PP	2	19	9	92	M12 x 65
PG252	PG252PP	2	12	3	72	M10 x 50
PG366	PG366PP	3	19	9	111	M12 x 65

BI-METAL PG CLAMPS - DOUBLE & TRIPLE BOLT

- For aluminium main conductors and copper tap-off conductors
- Pressure pad, hex. head screws and nuts
- Clamp body and pressure pad is made of high strength aluminium alloy with compressed bi-metallic sheet for copper tap-off
- Screws: DIN 933 – Steel, grade 8.8 hot-dip galvanised
- Nuts: DIN 934 – Steel, grade 8, hot-dip galvanised



CAT NO.	CONDUCTOR CROSS SECTION		CONDUCTOR RANGE O.D.		LENGTH A mm	BOLT
	ALUMINIUM mm ²	COPPER mm ²	ALUMINIUM mm ²	COPPER mm ²		
WG3909	16-70	6-50	5.1 to 11.7	2.7 to 9.0	40	2 x M8 x 40
WG3911	12-150	90-95	6.3 to 15.7	4.1 to 12.5	49	2 x M8 x 45
WG3913	35-185	35-185	7.5 to 17.5	7.5 to 17.5	65	2 x M10 x 60
WG3915	95-240	70-185	12.5 to 21.0	10.5 to 17.6	105	3 x M10 x 60

ALUMINIUM PG CLAMPS – DOUBLE BOLT



- Suitable for aluminium conductors
- Pressure pad, 2 hex, head screws and nuts
- Materials: • Clamp body and pressure pad – high strength aluminium alloy heat treated
- Screws: DIN 933 – steel, grade 8.8 hot-dip galvanised
- Nuts: DIN 934 – Steel grade 8, hot-dip galvanised

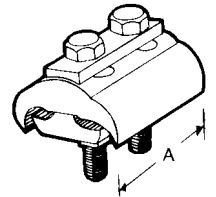

CAT NO.	CROSS SECTION mm ²	CONDUCTOR RANGE O.D.	LENGTH A mm	BOLTS
WG3587	16-35	5.1 to 7.5	41	2 x M7 x 30
WG3588	16-50	5.1 to 9.0	45	2 x M8 x 40
WG3589	16-70	5.1 to 10.5	49	2 x M8 x 45
WG3590	16-95	5.1 to 12.5	55	2 x M8 x 45
WG3591	16-120	5.1 to 14.0	55	2 x M8 x 50
WG3932	25-150	6.3 to 15.7	61	2 x M10 x 50
WG3593	38-185	7.5 to 17.5	65	2 x M10 x 60
WG3594	70-240	10.5 to 20.2	70	2 x M10 x 70



COPPER PG CLAMPS – SINGLE BOLT

- Suitable for copper conductors
- Pressure pad, 1 hex, head screw and nut
- Materials: • Clamp body and pressure pad – electrolytic copper, E-Cu F30
- Screws: DIN 933 – bronze, having a minimum tensile strength of 60 kp/mm²
- Nuts: DIN 934 – copper, having a minimum tensile strength of 60 kp/mm²

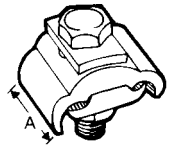

CAT NO.	CROSS SECTION mm ²	CONDUCTOR RANGE O.D.	LENGTH A mm	BOLTS
WG3005	2.5-16	1.8 to 5.1	16	M5 x 20
WG3006	4-25	2.3 to 6.3	18	M6 x 25
WG3007	6-35	2.7 to 7.5	20	M7 x 30
WG3008	6-50	2.7 to 9.0	22	M8 x 35

6

COPPER PG CLAMPS – DOUBLE BOLT

- Suitable for copper conductors
- Pressure pad, 2 hex, head screws and nuts
- Materials: • Clamp body and pressure pad – electrolytic copper, E-Cu F30
- Screws: DIN 933 – bronze, having a minimum tensile strength of 60 kp/mm²
- Nuts: DIN 934 – copper, having a minimum tensile strength of 60 kp/mm²

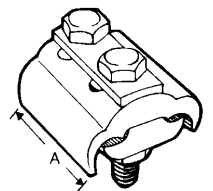

CAT NO.	CROSS SECTION mm ²	CONDUCTOR RANGE O.D.	LENGTH A mm	BOLTS
WG3025	2.5-16	1.8 to 5.1	24	M5 x 25
WG3026	4-25	2.3 to 6.3	30	M7 x 25
WG3027	6-35	2.7 to 7.5	32	M7 x 30
WG3028	6-50	2.7 to 9.0	35	M8 x 40
WG3029	6-70	2.7 to 10.5	38	M8 x 40
WG3030	16-95	5.1 to 12.5	40	M8 x 40
WG3032	16-150	1.5 to 15.7	50	M10 x 50

SPLIT BOLT CONNECTORS

- For tapping or joining aerial hard drawn or insulated copper conductors
 - Made from hard grade, high conductivity brass
- Captive saddle applies distributed pressure to conductors to ESAA specifications



	CAT NO.		ESSA TYPE	MAX CONDUCTOR SIZE		SLOT WIDTH mm
	NATURAL BRASS	ELECTRO TINNED		AREA mm ²	OVERALL DIA.	
SB22		SB22ET	A	16	5.10	5.3
SB24		SB24ET	B	35	7.65	8.3
SB25		SB25ET	C	70	10.70	10.9
SB26		SB26ET	D	95	12.90	12.9
SB28		SB28ET	E	185	18.50	18.5



CONTENTS

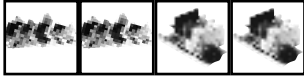

TERMINAL BLOCKS

SECTION 7

SECTION 7	TERMINAL BLOCKS57
	STANDARD RANGE RAIL MOUNTED	
	TERMINAL BLOCKS58
	STANDARD RANGE RAIL MOUNTED	
	TERMINAL BLOCKS59
	STUD TYPE RAIL MOUNTED	
	TERMINAL BLOCKS60
	FIXED SCREW TERMINAL	
	BLOCKS & ACCESSORIES61
	QUICK CONNECT TERMINAL BLOCKS62
	TERMINAL CONFIGURATIONS	
	& ORDERING GUIDE62

CATALOGUE INDEX

INDEX





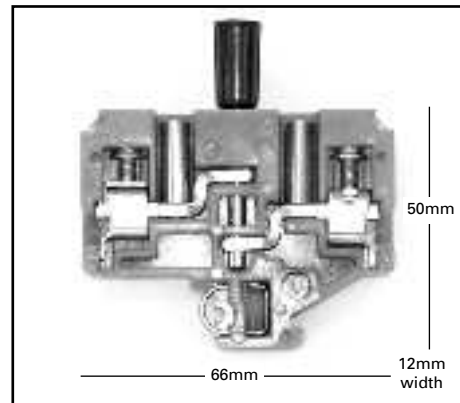

STANDARD RANGE RAIL MOUNTED TERMINAL BLOCKS

- Manufactured in melamine • Standard colour orange
- Higher current ratings may be obtained at lower ambients

	CAT. NO.	RATED AT 600V AC	CONDUCTOR SIZE mm ²
	H2608	25 amps	0.5-10

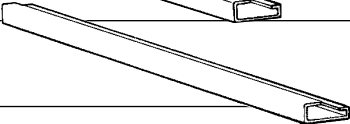
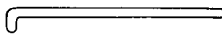

CATALOGUE NO. H2608 Metering Block

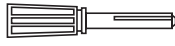
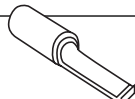
ACCESSORIES		CAT. NO.
Standard End Plate (melamine)		H2609
Partition		H3865
End Clamp (Nylon)		H2232
460mm Mounting Rail		H2233
1 metre Mounting Rail		H2233A
1 metre Locking Pin		H2234A
*Bridging Link <small>*Bridging Link H2633 supplied in either 2 holes or 10 holes. Specify Cat. No. H2633-2 or H2633-10,</small>		H2633
Disconnect Plug		H2650
Lip Blade Terminal		H4207, H4208, H4209

STANDARD RANGE RAIL MOUNTED TERMINAL BLOCKS

- Manufactured in melamine
- Standard colour orange
- Higher current ratings may be obtained at lower ambients







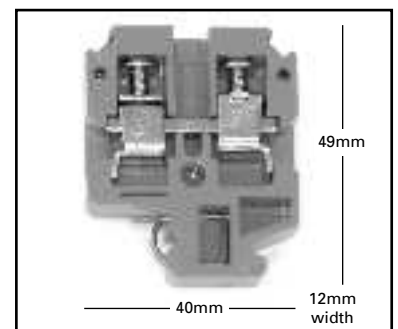
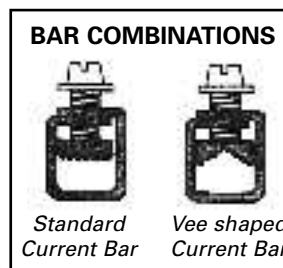

CAT. NO.	RATED AT 600V AC	CONDUCTOR SIZE mm ²
H2238	48 amps	0.5-10
H2238V	65amps	2.5-12

Note: Bar Combinations H2238, H2643 are available with a "vee" shaped current bar to accommodate a larger conductor. When ordering use Cat No. plus suffix "V" eg. H2238V, H2643V

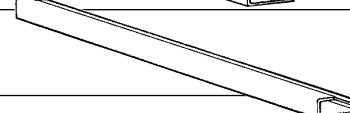
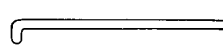
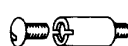

CATALOGUE NO. H2238, H2238V Vee shaped current bar

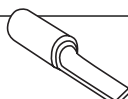





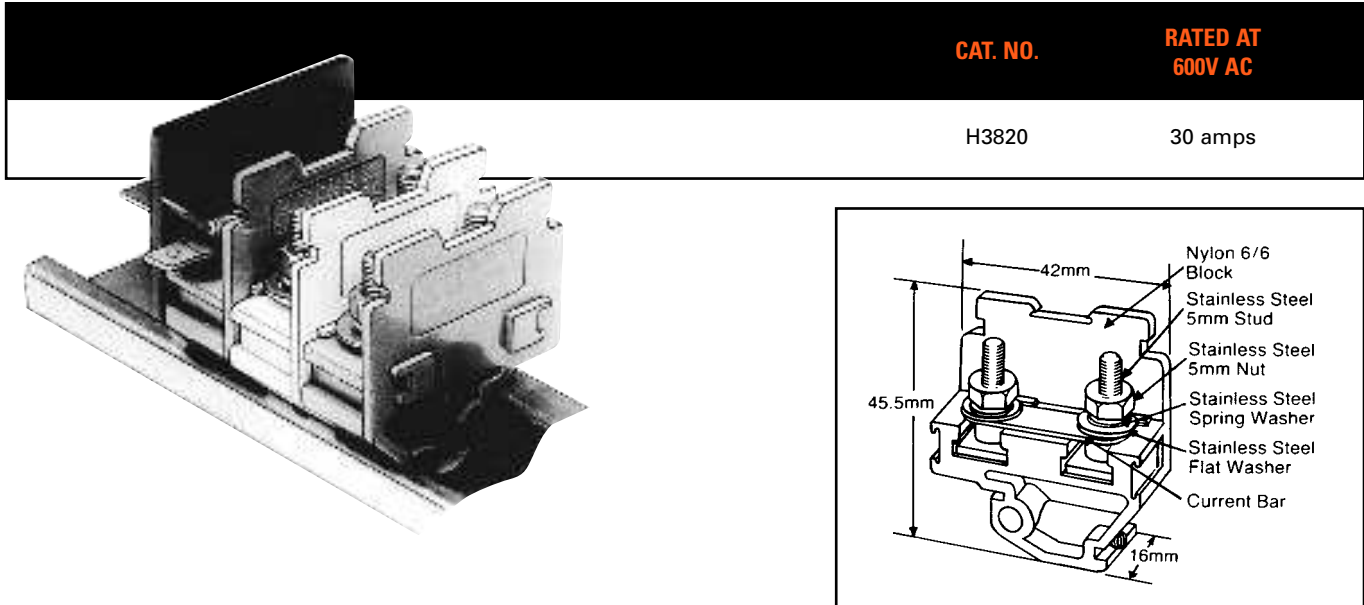

ACCESSORIES		CAT. NO.
Standard End Plate (melamine)		H2239
Partition		H3863
End Clamp (Nylon)		H2232
460mm Mounting Rail		H2233
1 metre Mounting Rail		H2233A
1 metre Locking Pin		H2234A
Link support and screw		H2236M
Bridging Link		H2631
Lip Blade Terminal		H4207, H4208, H4209

STUD TYPE RAIL MOUNTED TERMINAL BLOCKS

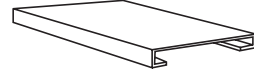
• A more permanent connection free from loose connections caused by vibration • Being a fixed stud, eye or slotted terminals can be used on wiring to ensure a more positive connection • Voltage – 500V max. conductor 7/1.70mm copper

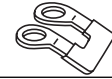

CATALOGUE NO. H3820, Nylon 6/6 120°C, Hardware: Stainless Steel

ACCESSORIES		CAT. NO.
End Plate		H3821
Partition		H3865
Cover (standard length 2m)		H3822
Marker Strip		H3823
Bridging Link		H3824P
1 metre Locking Pin		H2234A
460mm Mounting Rail		H2233
1 metre Mounting Rail		H2233A
Nylon End Clamp		H2232

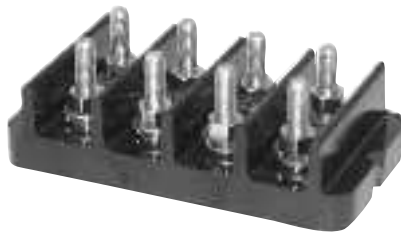
FIXED SCREW TERMINAL BLOCKS & ACCESSORIES

H2502 4 WAY (120 L X 45 W)



 H2501 6 WAY (120 L X 45 W)
 H2511 4 WAY (86 L X 45 W)
 H2512 5 WAY (104 L X 45 W)

TERMINAL BLOCK	TYPE	COMPLETE WITH	AMP RATING AT 600V AC	LINKS	CLEAR POLY. COVERS	COVER SECURING NUT
H2501N	6 way	Stainless Steel 5mm studs, nuts, spring & flat washers, H2501M slotted link	80	H2501M slotted	H2516 H2517	H2508 H2508
H2501EN	6 way	Stainless Steel 5mm studs, nuts, spring & flat washers, H2501L solid link	80	H2501L solid	H2516 H2517	H2508 H2508
H2502	4 way	Stainless Steel OBA studs, nuts, spring washers, H2502L solid link	80	H2502L solid	H2516 H2517	H2509 H2509
H2502E	4 way	Stainless Steel OBA studs, nuts, spring washers, H2502M slotted link	80	H2502M slotted	H2516 H2517	H2509 H2509
H2511N	4 way	Stainless Steel 5mm studs, nuts, spring washers, H2501L solid link	80	H2501L solid	-	-
H2512N	5 way	Stainless Steel 6mm studs, nuts, spring washers, H2501L solid link	80	H2501L solid	-	-

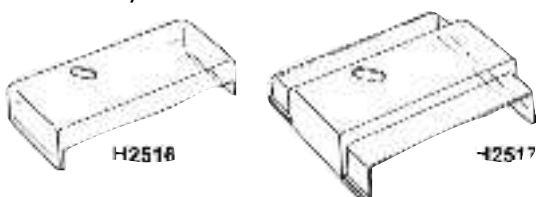
Clear Polycarbonate Covers

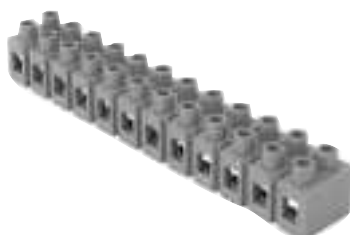

12 WAY TERMINAL STRIP

- Melamine body
- Phosphor bronze wire protector to prevent clamping screw from pinching the conductor
- Clamping contact is vibration proof
- May be cut to desired length

 H2519
 LENGTH 133mm

QUICK CONNECT TERMINAL BLOCKS

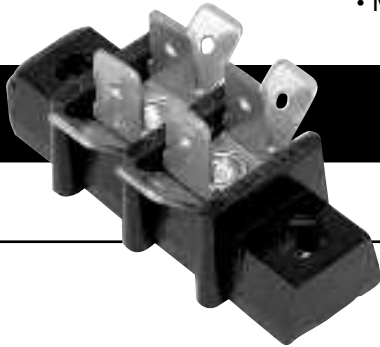
- Available in 1 to 17 stations (including mounting holes) • QC male outlets to clients specifications
- Mounting holes 4.8mm dia, hole centres are 11.1mm apart • Economical, convenient, safe and simple
 - Special blocks can be made to suit individual requirements
 - Used by all leading Domestic Appliance Manufacturers
 - Manufactured to Australian standards



CAT. NO.

RATED AT
240V AC

TB SERIES

20 amps

TERMINAL CONFIGURATIONS & ORDERING GUIDE

- All parts rated 20 amps screwed connections • Active (A), Neutral (N), Earth (E), engraving available
- Plating is an optional extra • All tabs suit 6.3mm receptacles • Specify terminal style required by using table shown

tyco
Electronics

CUSTOMER.....
.....
.....

"NOT TO SCALE"

															15
															14
															13
															12
															11
															10
															9
															8
															7
															6
															5
															4
															3

ORDERING PROCEDURE

1. SELECT THE ROW SHOWING THE NUMBER OF HOLES YOU REQUIRE ON THE MOULDINGS.
2. WRITE INTO EACH SQUARE THE TAB TYPE OR FIXING HOLE REQUIRED. e.g. A. C. X etc.
3. A TYPICAL 4 WAY 6 HOLE BLOCK WOULD LOOK LIKE THIS.

		•		•	
X	A	H	J	N	X
		A	N •	E	

4. MARK • INDICATES POSITION OF SCREW
5. PLEASE MARK SCREW TERMINAL A. N. E OR P (active, neutral, earth or phase) IN SQUARE IF REQUIRED.
6. OTHER TAB VARIATIONS AVAILABLE ON APPLICATION.

PART NO. _____

Z	
B	
C	
D	
E	
CZ	
F	
G	
H	
U	
I	
J	
K	
N	
Bridge	
X	Fixing Hole

CONTENTS

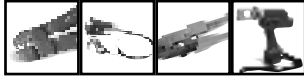

APPLICATION TOOLING

SECTION 8

SECTION 8	APPLICATION TOOLING	.63
	ERGONOMIC DESIGN HAND CRIMP TOOLS	.64
	ECONOMY RANGE CRIMP TOOLS	.66
	PROFESSIONAL RANGE CRIMP TOOLS	.68
	HEAVY DUTY HAND OPERATED	
	HYDRAULIC CRIMP TOOLS	.70
	HEAVY DUTY BATTERY OPERATED	
	HYDRAULIC CRIMP TOOLS	.72
	ACCESSORIES FOR BATTERY	
	POWERED TOOLS	.74
	HEAVY DUTY HYDRAULIC CRIMPING HEADS	.75
	HEAVY DUTY HYDRAULIC CRIMPING HEADS	.76
	HEAVY DUTY HYDRAULIC CRIMPING HEADS	.77
	HYDRAULIC PUMPS AND CONTROLLERS	.78
	CABLE CUTTERS	.80
	BATTERY OPERATED CABLE CUTTERS	.81
	HYDRAULIC CABLE CUTTERS	.82
	DATA PRODUCTS TOOLS	.84
	CABLE STRIPPERS	.85
	CRIMPING DIES	.86
	12 TONNE DIES	.87
	HEXAGONAL CRIMP DIES – COPPER	.87
	HEXAGONAL CRIMP DIES – ALUMINIUM	.87
	INDENT CRIMP DIES – SECTOR ALUMINIUM	.87
	HEXAGONAL CRIMP DIES – HALF HEX (FOR FLEXIBLE CABLES)	.88
	HEXAGONAL CRIMP DIES –	
	C CONNECTORS	.88
	HEXAGONAL CRIMP DIES – STEEL CORES OF ACSR CONDUCTOR	.88
	HEXAGONAL CRIMP DIES –	
	INSULATED ABC CONNECTORS	.88
	DIES FOR 5 TONNE TOOL	.89
	DIES FOR 18 TONNE TOOL	.89
	DIES FOR 40 TONNE TOOL	.89
	DIES FOR 40 TONNE TOOL	.90
	HEXAGONAL CRIMP DIES - HALF HEX (FOR FLEXIBLE CABLES)	.90
	#TY SERIES CRIMPING TOOL	.90
	#TR SERIES CRIMPING TOOL	.90

ERGONOMIC DESIGN HAND CRIMP TOOLS

The world's first truly user friendly crimp tool range, with careful 'ergonomical' consideration given to the shape, weight and balance whilst maintaining optimum mechanical advantage. Designed to minimise RSI and associated workplace injuries, these award winning tools provide precise and dependable crimps, without undue discomfort and strain to the user.

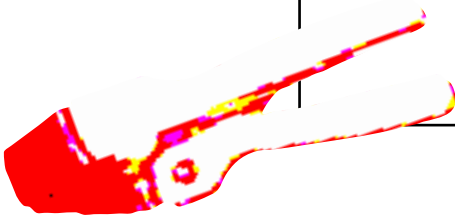

CAT NO.	DESCRIPTION
#120	Ergonomic design ratchet crimp tool for red, blue and yellow preinsulated terminals. RANGE..... Red, blue and yellow, 0.75 to 6.0mm ² CRIMP TYPE..... Oval LENGTH..... 255mm WEIGHT 550g

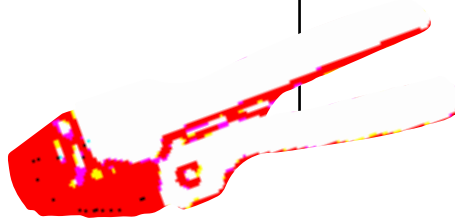

CAT NO.	DESCRIPTION
#121	Ergonomic design ratchet crimp tool for boot lace terminals. Terminals load from the side. RANGE..... 10 to 25mm ² CRIMP TYPE D shape LENGTH..... 255mm WEIGHT 550g

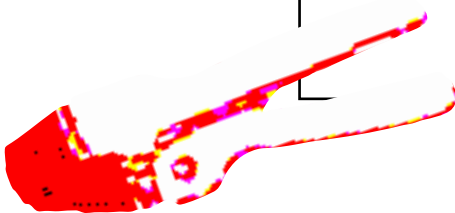

CAT NO.	DESCRIPTION
#122	Ergonomic design ratchet crimp tool for boot lace terminals. Terminals load from the side. RANGE..... 35 to 50mm ² CRIMP TYPE D shape LENGTH..... 255mm WEIGHT 550g

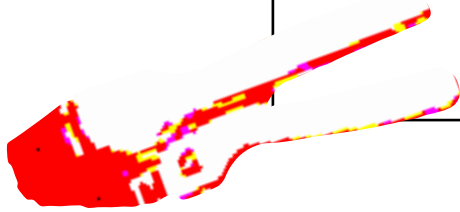

CAT NO.	DESCRIPTION
#124	Ergonomic design ratchet crimp tool for uninsulated terminals. RANGE..... 4 to 10mm ² CRIMP TYPE..... Indent LENGTH..... 255mm WEIGHT 550g



CAT NO.	DESCRIPTION
#125	Ergonomic design ratchet crimp tool for boot lace terminals. Terminals load from the front of the tool. RANGE..... 0.5 to 6.0mm ² CRIMP TYPE..... D shape LENGTH..... 255mm WEIGHT 550g



CAT NO.	DESCRIPTION
#126	Ergonomic design ratchet crimp tool for boot lace terminals. Terminals load from the side. RANGE..... 4 to 10mm ² CRIMP TYPE..... D shape LENGTH..... 255mm WEIGHT 550g

ALTERNATE AND REPLACEMENT JAWS AVAILABLE UPON REQUEST



ECONOMY RANGE CRIMP TOOLS

A range of high quality, but economically priced hand crimp tools ideal for the occasional professional user or serious hobbyist. These easy to use precision engineered tools produce a first class job and offer the user great value for money.



CAT NO.	DESCRIPTION
#76B	<p>Non ratchet pliers for pre-insulated and uninsulated terminals. Includes wire cutting and stripping positions.</p> <p>RANGE..... 0.5mm² to 4.0mm²</p> <p>CRIMP TYPE..... Pre-insulated – Oval; Uninsulated – Indent</p> <p>LENGTH..... 203mm</p> <p>WEIGHT 250g</p>



CAT NO.	DESCRIPTION
#61	<p>Non ratchet pliers for open barrel, roll in crimp type terminals such as H1972. Features a built in wire stripper and cutter.</p> <p>RANGE..... 0.75mm² to 2.1mm²</p> <p>CRIMP TYPE..... Roll-in for open barrel terminals</p> <p>LENGTH..... 210mm</p> <p>WEIGHT 230g</p>



CAT NO.	DESCRIPTION
#147A	<p>Non ratchet pliers for micro and flag QC open barrel terminals. Features a built in wire stripper and cutter.</p> <p>CRIMP TYPE..... Roll-in for open barrel terminals</p> <p>LENGTH..... 210mm</p> <p>WEIGHT 230g</p>



CAT NO.	DESCRIPTION
#00	<p>General purpose pliers for uninsulated copper lugs and links. Simple and robust. A must for every tradesman.</p> <p>RANGE..... 0.5mm² to 10.0mm²</p> <p>CRIMP TYPE..... Indent</p> <p>LENGTH..... 254mm</p> <p>WEIGHT 450g</p>



CAT NO.	DESCRIPTION
#102	<p>Ratchet type tool for pre-insulated and supergrip terminals. The ratchet ensures a complete crimp every time. A must have tool for every tradesman.</p> <p>RANGE..... Red, Blue and Yellow pre-insulated (0.5 to 5.5mm²)</p> <p>CRIMP TYPE..... Oval on conductor/Diamond on insulation</p> <p>LENGTH..... 230mm</p> <p>WEIGHT 550g</p>

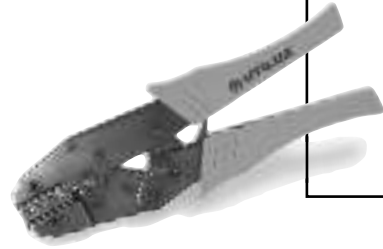

CAT NO.	DESCRIPTION
#102M	Ratchet type tool for miniature yellow type pre-insulated terminals (eg. H4200) RANGE..... 0.2mm ² to 0.5mm ² CRIMP TYPE..... Oval LENGTH..... 230mm WEIGHT 230g



CAT NO.	DESCRIPTION
#102U	Ratchet type tool for uninsulated terminals. The ratchet ensures a complete crimp every time. A must have tool for every tradesman. RANGE..... 0.5 to 8.0mm ² CRIMP TYPE..... Indent LENGTH..... 230mm WEIGHT 550g



CAT NO.	DESCRIPTION
#112	Ratchet type tool for boot lace terminals. The ratchet ensures a complete crimp every time. A must have tool for every tradesman. RANGE..... 0.5mm ² to 10mm ² CRIMP TYPE..... U LENGTH..... 230mm WEIGHT 550g

JAW NO.	CABLE (mm ²)
1	0.5 to 0.75
2	1.0
3	1.5
4	2.5
5	4 to 6
6	10

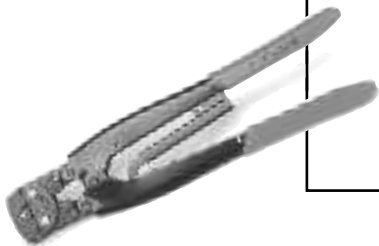

CAT NO.	DESCRIPTION
#11C	Ratchet type tool for RED (0.5 to 1.5mm ²) pre-insulated terminals only, with terminal locator. Ideal for OEM and production applications. Red handles match terminal colour, and identify which terminals can be crimped. CRIMP TYPE..... Oval on conductor/Diamond on insulation LENGTH..... 265mm WEIGHT 540g



CAT NO.	DESCRIPTION
#12C	Ratchet type tool for BLUE (1.5 to 2.5mm ²) pre-insulated terminals only, with terminal locator. Ideal for OEM and production applications. Blue handles match terminal colour, and identify which terminals can be crimped. CRIMP TYPE..... Oval on conductor/Diamond on insulation LENGTH..... 265mm WEIGHT 540g

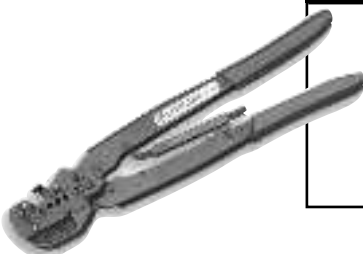

CAT NO.	DESCRIPTION
#13B	Ratchet type tool for YELLOW (2.5 to 6.0mm ²) pre-insulated terminals only, with terminal locator. Ideal for OEM and production applications. Yellow handles match terminal colour, and identifies which terminals can be crimped. CRIMP TYPE..... Oval on conductor/Diamond on insulation LENGTH..... 330mm WEIGHT 970g

PROFESSIONAL RANGE CRIMP TOOLS

Built to last, these tools are ideal for the professional or specialist. The precision crafted mechanisms and uncompromised material quality of these tools will ensure years of trouble free operation, and results you can depend on.

CAT NO.	DESCRIPTION
#63	Bench mounted air operated crimp tool with interchangeable crimp jaws for a range of applications. Includes foot operated controller and pneumatic hoses. Five interchangeable crimp jaws. RANGE..... Up to 6mm ² terminals CRIMP TYPE Depends on jaws selected INPUT..... 490kPa air OUTPUT..... 1.3 tons WEIGHT 2kg
Interchangeable Jaws for #63 bench mounted crimper	#4BJAWS/1..... For RED pre-insulated terminals #4UJAWS/1 For BLUE pre-insulated terminals #5UJAWS/1 For YELLOW pre-insulated terminals #1JAWS/1 For uninsulated lugs and links 1.5 to 6.0mm ² #7JAWS/1 For closed end connectors 0.5 to 6.0mm ² Custom made jaws available on request.

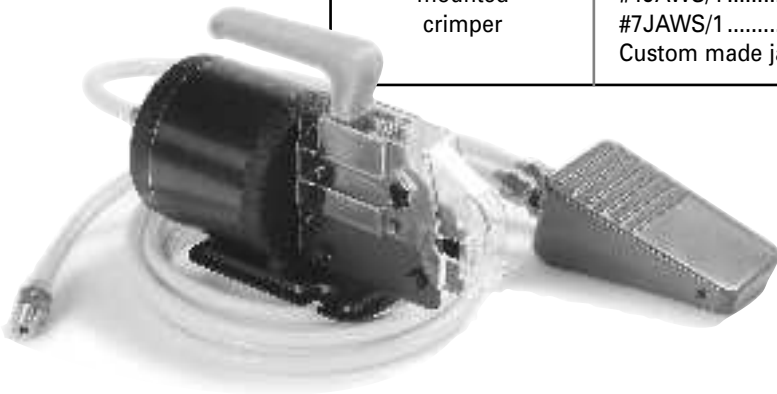

CAT NO.	DESCRIPTION
#16B	Ratchet type tool for uninsulated copper lugs (CG series). The long handles require less crimping effort. RANGE..... 0.5 to 10mm ² CRIMP TYPE Indent LENGTH..... 250mm WEIGHT 700g



CAT NO.	DESCRIPTION
#18	Ratchet type tool for uninsulated copper lugs (CG series). The long handles require less crimping effort. RANGE..... 5 to 16mm ² CRIMP TYPE Indent LENGTH..... 330mm WEIGHT 700g

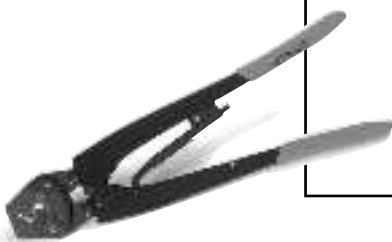

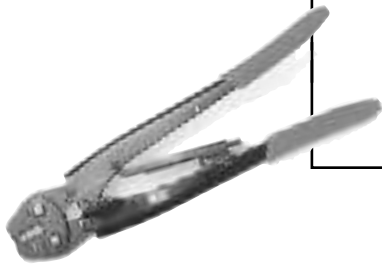

CAT NO.	DESCRIPTION
#28A	Ratchet type tool for Utilux closed end connectors. RANGE..... 2.5 - 10mm ² CRIMP TYPE..... Oval LENGTH..... 320mm WEIGHT 600g

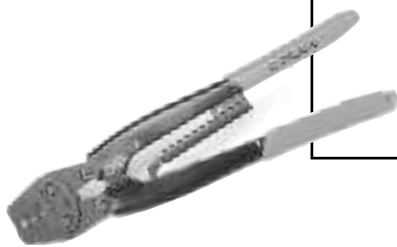

CAT NO.	DESCRIPTION
#17	Ratchet type tool for crimping open barrel type terminals RANGE..... 0.7 to 2.1mm ² CRIMP TYPE..... Roll in LENGTH..... 280mm WEIGHT 600g

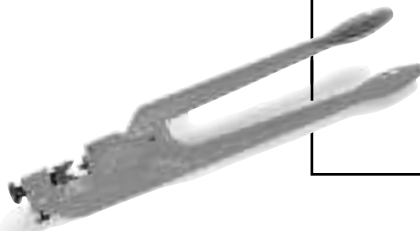

CAT NO.	DESCRIPTION
#20	Mechanical crimper for copper lugs and links. Dial adjustable crimp depth with cable size indicator. RANGE..... 16 to 95mm ² CRIMP TYPE..... Indent, depth adjustable LENGTH..... 560mm WEIGHT 3.2kg

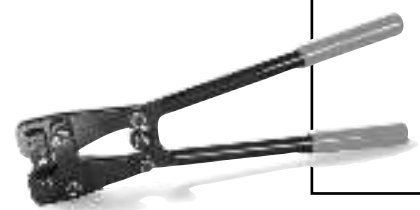

CAT NO.	DESCRIPTION
#21	Hand operated, mechanical lever tool for copper lugs and links. Features built in, selectable crimp die set for a range of lug and link sizes. RANGE..... 6mm ² to 50mm ² CRIMP TYPE..... Hexagonal LENGTH..... 410mm WEIGHT 1.4kg

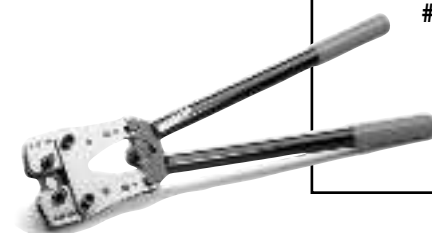

CAT NO.	DESCRIPTION
#22	Hand operated, mechanical lever tool for copper lugs and links. Features built in, selectable crimp die set for a range of lug and link sizes. RANGE..... 6mm ² to 120mm ² CRIMP TYPE..... Hexagonal LENGTH..... 670mm WEIGHT 3.9kg

HEAVY DUTY HAND OPERATED HYDRAULIC CRIMP TOOLS

The precision engineered hydraulic components used in these tools set the standard which others strive to achieve, and the user benefits from faster crimp times, less handle effort, easier maintenance, longer tool life and more dependable results.

The two stage pumping mechanism in selected products means the ram advances quickly up to the connector, then slows as the hydraulic effort is translated into crimping force. Automatic by-pass valves, provide positive feedback to the user when the tool has reached its rated output, and the crimp is complete.

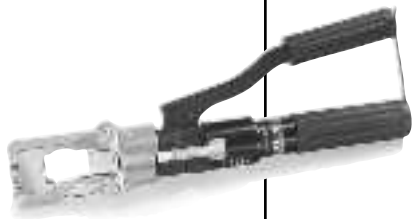

CAT NO.	DESCRIPTION
#111	<p>Compact hydraulic tool featuring 'flip top' head ideal for LVABC work and smaller copper and aluminium connectors. Versatile multi-sized dies means only a few die sets are required to cover a broad range of conductor sizes. (Die sets sold separately).</p> <p>FEATURES..... Automatic by-pass valve, Spring assisted head latch, Trigger operated die retractor, Adjustable ram stroke.</p> <p>RANGE..... 6mm² – 150mm² (LVABC) 6mm² – 120mm² (Cu and Al)</p> <p>OUTPUT..... 5.2 tonne</p> <p>RAM STROKE..... 10 to 15mm</p> <p>DIE SET '111' type dies</p> <p>LENGTH..... 370mm</p> <p>WEIGHT 2 kg (tool only with die set loaded)</p> <p>PACKAGING Metal carry case, with die compartment.</p>

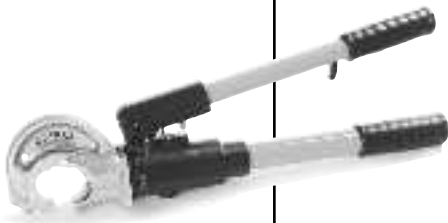

CAT NO.	DESCRIPTION
#38A	<p>Robust and built to last, this hydraulic tool sets the standard for other 12t hydraulic tools. Precision engineered hydraulic components for maximum reliability and ease of use and maintenance. (Die sets sold separately).</p> <p>FEATURES..... Two stage rapid advance pumping action Automatic pressure bypass, Replaceable bypass valve, 180 deg swivel head, Fibreglass handles.</p> <p>RANGE..... Up to 300mm²</p> <p>OUTPUT..... 11.3 tonnes</p> <p>RAM STROKE..... 25mm</p> <p>DIE SET '38' type dies</p> <p>LENGTH..... 585mm</p> <p>WEIGHT 6.0kg (tool only with die set loaded)</p> <p>PACKAGING Heavy duty plastic carry case, with die compartment.</p>

[View Parts List](#)

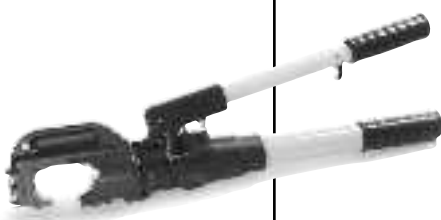

CAT NO.	DESCRIPTION
#98	<p>Like the #38A this tool is built to last, and features an extra wide 'throat' opening, allowing removal of the tool over cables up to 38mm in overall diameter. Ideal for straight through cable joints. (Die sets sold separately).</p> <p>FEATURES..... Two stage rapid advance pumping action Automatic pressure bypass, Replaceable bypass valve, 180 deg swivel head, Fibreglass handles.</p> <p>RANGE..... Up to 300mm²</p> <p>OUTPUT..... 12 tonnes</p> <p>RAM STROKE..... 38mm</p> <p>DIE SET '38' type dies</p> <p>LENGTH..... 640mm</p> <p>WEIGHT 7.7kg (tool only with die set loaded)</p> <p>PACKAGING Heavy duty plastic carry case, with die compartment.</p>

[View Parts List](#)



CAT NO.	DESCRIPTION
#41A	Complete hydraulic crimping tool kit. Refer individual components for detailed specifications. KIT INCLUDES..... #P80 – 10.000 psi hand operated hydraulic pump #41AH – 12t hydraulic crimp head #HYH2M – 2m hydraulic hose with couplings Timber carry box WEIGHT 29kg (complete) BOX DIM. 740mm(L) x 270mm(W) x 290mm(H)

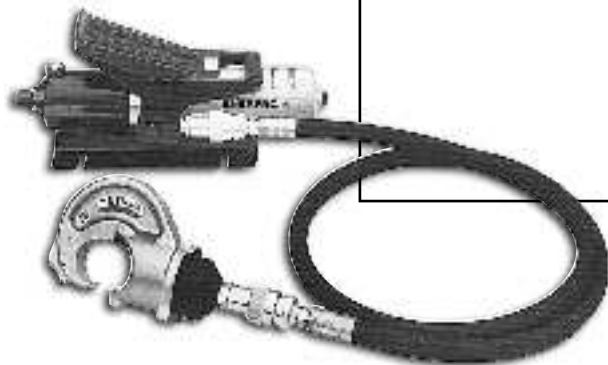

CAT NO.	DESCRIPTION
#42A	Complete air/hydraulic crimping tool kit. Requires 400-700kPa compressed air supply. Refer individual components for detailed specifications. KIT INCLUDES..... #PA133 – Air operated hydraulic pump #41AH – 12t hydraulic crimp head #HYH2M – 2m hydraulic hose with couplings Timber carry box WEIGHT 24kg (complete) BOX DIM. 740mm(L) x 270mm(W) x 290mm(H)

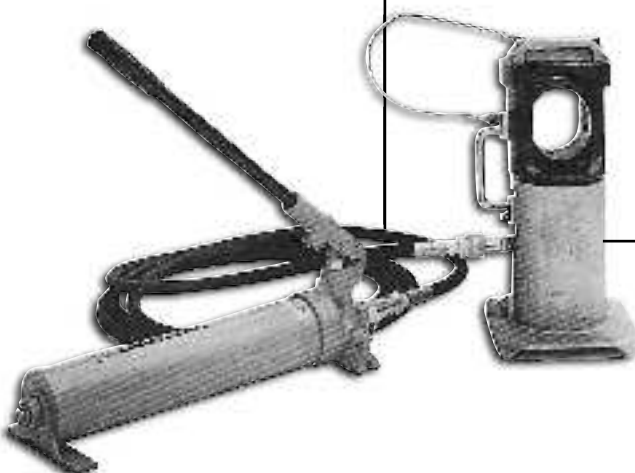

CAT NO.	DESCRIPTION
#40B	The tool kit for large line and cable work. A complete package of precision engineered components for the most demanding applications. Refer individual components for detailed specifications. KIT INCLUDES..... #40BH – 60 tonne compression head #P80 – 10,000psi hand pump #HYH2M, – 2m hydraulic hose with couplings Aluminium compression head stand Timber carry box WEIGHT 51kg (complete) BOX DIM..... 740mm(L) x 270mm(W) x 290mm(H)



CAT NO.	DESCRIPTION
#38ROBO	<p>Self contained heavy duty tool, requiring no external hoses or attachments. (Die sets sold separately).</p> <p>INCLUDES 2 x BP70R batteries 1 x CH3FC battery charger Shoulder strap</p> <p>RANGE..... Up to 300mm²</p> <p>FEATURES Large handle opening for gloved work, LED battery charge indicator, Rapid ram advance, Rocker switch for ram advance/retract, 350 deg swivel head</p> <p>OUTPUT..... 11.3 tonnes</p> <p>RAM STROKE..... 25mm</p> <p>DIE SET '38' type dies</p> <p>LENGTH..... 435mm(L) x 275mm(H) x 90mm(W)</p> <p>WEIGHT 7.5kg (tool only with die set loaded)</p> <p>PACKAGING Plastic carry case contains all components</p>

[View Parts List](#)



CAT NO.	DESCRIPTION
#98ROBO	<p>Self contained heavy duty tool, requiring no external hoses or attachments. (Die sets sold separately). This tool has the widest jaw opening in its class (42mm) making removal from large cables easy.</p> <p>INCLUDES 2 x BP70R batteries 1 x CH3FC battery charger Shoulder strap</p> <p>FEATURES Extra wide jaw opening (42mm) Rapid ram advance Large handle opening for gloved work, 350 deg swivel head LED battery indicator Rocker switch for ram advance/retract,</p> <p>OUTPUT..... 11.3 tonnes</p> <p>RAM STROKE..... 42mm</p> <p>DIE SET '38' type dies</p> <p>LENGTH..... 480mm</p> <p>WEIGHT 8.5kg (tool only with die set loaded)</p> <p>PACKAGING Plastic carry case contains all components</p>

[View Parts List](#)

ACCESSORIES FOR BATTERY POWERED TOOLS



CAT NO.	DESCRIPTION
BP70E	Rechargeable battery pack for all Utilux battery operated tools. CAPACITY 1.9 ampere hour CHARGE TIME..... 95min with CH3FC & CH-70DC, 25 min with CH35EMC OUTPUT VOLTAGE.. 14.4VDC SIZE..... 100mm(L) x 137mm(H) x 70mm(W) WEIGHT 800g



CAT NO.	DESCRIPTION
BP70EI	Intelligent rechargeable battery pack with LED indicator, for all Utilux battery operated tools. Indicator shows charge and battery life status. CAPACITY 1.9 ampere hour CHARGE TIME..... 1 hr with CH3FC & CH-70DC, 25 min with CH35EMC OUTPUT VOLTAGE.. 14.4VDC SIZE..... 100mm(L) x 137mm(H) x 70mm(W) WEIGHT 820g



CAT NO.	DESCRIPTION
BP250R	Extra heavy duty rechargeable battery pack for all Utilux battery operated tools. Includes waist strap. CAPACITY 4.0 ampere hour CHARGE TIME..... 3 hr with CH3FC, 45 min with CH3FR SIZE..... 228mm(L) x 159mm(H) x 40mm(W) WEIGHT 2.5kg



CAT NO.	DESCRIPTION
CH3FC	Mains powered standard battery charger for all Utilux battery packs. 1hr charge time for BP70R and BP70I battery packs. Includes LED charge indicator. SIZE..... 212mm(L) x 95mm(H) x 105mm(W) WEIGHT 1.9kg



CAT NO.	DESCRIPTION
CH3FR	Mains powered standard battery QUICK charger for all Utilux battery packs. 15mins charge time for BP70R and BP70I battery packs. Includes 4 function LED indicator. SIZE..... 212mm(L) x 95mm(H) x 115mm(W) WEIGHT 770g



CAT NO.	DESCRIPTION
CH-70DC	12V/24V powered battery charger for all Utilux battery packs. 1 hr charge time for BP70R and BP70I battery packs. Includes LED charge indicator, and vehicle cigarette lighter plug. SIZE..... 200mm(L) x 95mm(H) x 115mm(W) WEIGHT 700g

HEAVY DUTY HYDRAULIC CRIMPING HEADS

A versatile alternative to the self contained hand operated crimpers, these hydraulic crimping heads will attach to a range of hand operated or electric pumps. Designed and manufactured to the same exacting standards as the other hydraulic tools in the Utilux range.

All crimp heads are complete with a coupling to suit Utilux hydraulic hoses. Couplings can be changed to suit other equipment on request.



CAT NO.	DESCRIPTION
#111H	<p>Spring assisted latch 'H' frame head ideal for LVABC work. Connects to a range of 10,000 psi pumps. Includes coupling.</p> <p>FEATURES Spring assisted head latch, Adjustable ram stroke, Spring assisted ram retraction</p> <p>RANGE..... 6mm² – 150mm² (LVABC), 6mm² – 120mm² (Cu and Al)</p> <p>INPUT REQUIRED ... 10,000 psi, single acting pump</p> <p>OIL VOL. REQ'D 18cc</p> <p>OUTPUT..... 5.2 tonnes</p> <p>RAM STROKE..... 10 to 15mm</p> <p>DIE SET '111' type dies</p> <p>LENGTH..... 250mm</p> <p>WEIGHT 1.6kg (tool only with die set loaded)</p> <p>PACKAGING Metal carry case, with die compartment</p>



CAT NO.	DESCRIPTION
#41AH	<p>'C' frame general purpose compression head. Includes coupling.</p> <p>FEATURES Robust construction, Spring assisted ram retraction</p> <p>RANGE..... Up to 300mm²</p> <p>INPUT REQUIRED ... 10,000 psi, single acting pump</p> <p>OIL VOL. REQ'D 42cc</p> <p>OUTPUT..... 11.3 tonnes</p> <p>RAM STROKE..... 25mm</p> <p>DIE SET '38' type dies</p> <p>LENGTH..... 285mm</p> <p>WEIGHT 3.6kg (tool only with die set loaded)</p> <p>PACKAGING Metal carry case, with die compartment</p>

[View Parts List](#)



CAT NO.	DESCRIPTION
#98H	<p>'C' frame extra wide (38mm) compression head. Includes coupling.</p> <p>FEATURES Robust construction, Spring assisted ram retraction</p> <p>RANGE..... Up to 300mm²</p> <p>INPUT REQUIRED ... 10,000 psi, single acting pump</p> <p>OIL VOL. REQ'D 72cc</p> <p>OUTPUT..... 12 tonnes</p> <p>RAM STROKE..... 38mm</p> <p>DIE SET '38' type dies</p> <p>LENGTH..... 315mm</p> <p>WEIGHT 5.0kg (tool only with die set loaded)</p> <p>PACKAGING Metal carry case, with die compartment</p>

[View Parts List](#)

HEAVY DUTY HYDRAULIC CRIMPING HEADS

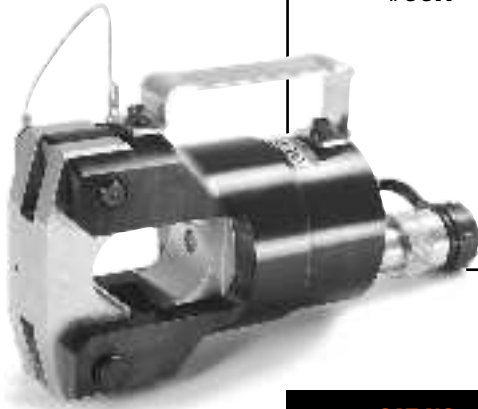

CAT NO.	DESCRIPTION
#66H	'U' frame increased capacity compression head. Includes coupling. FEATURES Robust construction, Spring assisted ram retraction, Carry handle RANGE..... Up to 500mm ² INPUT REQUIRED ... 10,000psi, single acting pump OUTPUT..... 22 tonnes DIE SET '66' and '38' type dies WEIGHT 7.8kg (tool only with die set loaded)



CAT NO.	DESCRIPTION
#50AH	'U' frame increased capacity compression head for up to 630mm ² connectors. Includes coupling. FEATURES Robust construction, Spring assisted ram retraction, Removable top die for easy application to cable, Light weight, Can use '38' type dies with #50ADH adaptor RANGE..... Up to 630mm ² INPUT REQUIRED ... 10,000psi, single acting pump OUTPUT..... 18 tonnes DIE SET '50' type dies, #50ADH '38' die adaptor LENGTH..... 240mm WEIGHT 5.9kg



CAT NO.	DESCRIPTION
#40BH	'U' frame high capacity compression head. Includes coupling and alloy stand. FEATURES Robust construction, Spring assisted ram retraction, Carry handle, Removable die cap RANGE..... Up to 1000mm ² INPUT REQUIRED ... 10,000psi, single acting pump OIL VOL. REQ'D 703cc OUTPUT..... 55 tonnes RAM STROKE..... 38.5mm DIE SET '40' type dies, '38' type dies using #40DH die holder SIZE..... 146mm(dia) x 446mm(H), in stand WEIGHT 22kg (tool only with die set loaded) PACKAGING Metal carry case

[View Parts List](#)

HEAVY DUTY HYDRAULIC CRIMPING HEADS



CAT NO.	DESCRIPTION
#67H	<p>'U' frame 100t capacity compression head. Suitable for transmission line work. Includes couplings.</p> <p>FEATURES..... Robust construction, Carry handle, Removable die cap</p> <p>RANGE..... Consult</p> <p>INPUT REQUIRED ... 10,000psi, double acting pump</p> <p>OIL VOL. REQ'D 314cc</p> <p>OUTPUT..... 100 tonnes</p> <p>RAM STROKE..... 22mm</p> <p>DIE SET..... Made to order '100' type dies</p> <p>SIZE..... 195mm(dia) x 360mm(H)</p> <p>WEIGHT 32kg</p>

[View Parts List](#)



CAT NO.	DESCRIPTION
#70H	<p>'U' frame 200t capacity compression head. Suitable for transmission line work. Includes couplings.</p> <p>FEATURES..... Robust construction, Carry handles, Removable die cap</p> <p>RANGE..... Consult</p> <p>INPUT REQUIRED ... 10,000psi, double acting pump</p> <p>OIL VOL. REQ'D 1,134cc</p> <p>OUTPUT..... 200 tonnes</p> <p>RAM STROKE..... 40mm</p> <p>DIE SET..... Made to order '200' type dies</p> <p>SIZE..... 270mm(dia) x 415mm(H)</p> <p>WEIGHT 84kg</p>

HYDRAULIC PUMPS AND CONTROLLERS

A range of quality hydraulic pumps and controllers to suit Utilux crimping heads and hydraulic hoses. Each pump has been selected to offer the optimum in performance and price for crimping applications. Pumps for special applications or requiring features not listed can be manufactured to order.



CAT NO.	DESCRIPTION
#PA133	<p>Complete air/hydraulic crimping tool kit. Requires 400-700kPa compressed air supply. Refer individual components for detailed specifications.</p> <p>FEATURES Rugged construction Swivel coupling 3 position treadle - advance, hold, release Base mounting slots</p> <p>WEIGHT 5.4kg (complete)</p> <p>SIZE..... 370mm(L) x 140mm(W) x 145mm(H)</p>



CAT NO.	DESCRIPTION
#P80	<p>Hand operated single acting hydraulic pump. Suitable for use with Model 111H40BH, 41AH Press Head and NO. 66 crimping head.</p> <p>FEATURES 2 speed mechanism for faster pumping, Built in oil pressure relief valve, Large oil capacity, Operating pressure 70,000kPa (10,000psi)</p> <p>OIL CAPACITY 2491cc</p> <p>OIL PORT 3/8" NPTF</p> <p>OUTPUT..... 10,000psi</p> <p>HANDLE EFFORT 63.5kg (max)</p> <p>SIZE..... 578mm(L) x 95.3mm(W) x 175mm(H)</p> <p>WEIGHT 12.7kg</p>



CAT NO.	DESCRIPTION
#PUJ1200E	<p>Mains (240V) powered portable single acting hydraulic pump. Suitable for use with a wide range of crimping heads and cylinders requiring 10,000psi supply and large oil volumes.</p> <p>FEATURES Robust construction, 2 stage pump 3m remote hand operated pendant controller</p> <p>OIL CAPACITY 2000cc</p> <p>OIL PORT 3/8" NPTF</p> <p>MOTOR 0.38kW</p> <p>OUTPUT..... 10,000psi</p> <p>SIZE..... 240mm(L) x 240mm(W) x 360mm(H)</p> <p>WEIGHT 10kg</p>

CABLE CUTTERS

A range of simple but robust cable cutters for a variety of applications.



CAT NO.	DESCRIPTION
#110	<p>Small single hand operated parrot beak style cutter, ideal for general applications. Precision blades make this tool ideal for cutting flexible copper cables.</p> <p>LENGTH..... 240mm WEIGHT 460g</p>



CAT NO.	DESCRIPTION
#108	<p>Gear driven large capacity ratchet cable cutter, with rapid blade advance. robust forged construction cuts up to 400mm² single core copper cable. Not suitable for steel.</p> <p>FEATURES Rubber handle grips, Single hand operation, Emergency release mechanism, Blade reversing lever</p> <p>LENGTH..... 260mm WEIGHT 1.1kg</p>

[View Parts List](#)

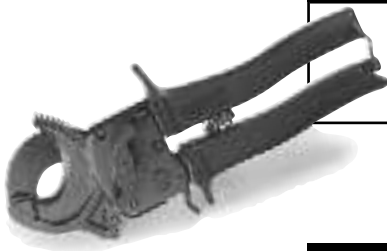

CAT NO.	DESCRIPTION
#109	<p>Smaller version of #108 cutter, for cables up to 300mm².</p> <p>LENGTH..... 230mm WEIGHT 520g</p>



CAT NO.	DESCRIPTION
#140	<p>Parrot beak style cable cutter for copper and aluminium conductors up to 240mm². Replacement blades available.</p> <p>LENGTH..... 610mm WEIGHT 1.8g</p>



CAT NO.	DESCRIPTION
#141	<p>Parrot beak style cable cutter for copper and aluminium conductors up to 500mm². Replacement blades available.</p> <p>LENGTH..... 805mm WEIGHT 2.8g</p>

BATTERY OPERATED CABLE CUTTERS

A range of simple but robust cable cutters for a variety of applications.

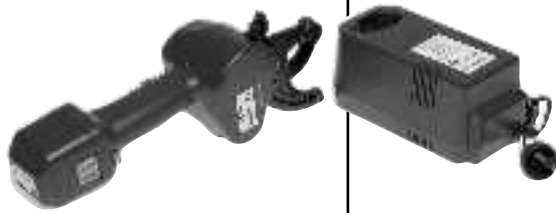

CAT NO.	DESCRIPTION
#REC-50U	<p>Portable gear driven cable cutter ideal for many applications. Specially designed to cut the toughest copper and aluminium cables in a limited amount of space.</p> <p>INCLUDES Cutter unit 1 x BP70R battery unit 1 x CH3FC battery charger</p> <p>FEATURES..... Eliminates possible RSI, Rocker switch control (fwd and reverse), Cuts clean with minimal distortion, Built in overload protection, Up to 100 cuts from single battery charge</p> <p>RANGE..... Up to 50mm OD non-ferrous cables SIZE..... 105mm(L) x 375mm(H) x 115mm(W) WEIGHT 2.0kg PACKAGING Metal carry case</p>

[View Parts List](#)



CAT NO.	DESCRIPTION
#S20AROBO	<p>Battery powered hydraulic cutter (refer #CCS20A for application and cutting range).</p> <p>INCLUDES Cutter unit 1 x BP70R battery unit 1 x CH3FC battery charger, Shoulder strap</p> <p>FEATURES..... Eliminates possible RSI, Flip top latched head Head rotates through 350 deg, Built in overload protection,</p> <p>RAM STROKE 20mm OUTPUT..... 6 tonnes SIZE..... 280mm(L) x 240mm(H) x 75mm(W) WEIGHT 3.2kg PACKAGING Durable plastic carry case</p>



CAT NO.	DESCRIPTION
#S440ROBO	<p>Battery powered hydraulic cutter (design for ACSR Cables.).</p> <p>INCLUDES Cutter unit 1 x BP70EI battery unit 1 x CH35EMC battery charger, Shoulder strap</p> <p>FEATURES..... Eliminates possible RSI, Flip top latched head Head rotates through 350 deg, Built in overload protection,</p> <p>RAM STROKE 40mm OUTPUT..... 7 tonnes SIZE..... 440mm(L) x 260mm(H) x 78mm(W) WEIGHT 6.0kg PACKAGING Durable plastic carry case</p>

HYDRAULIC CABLE CUTTERS

Quality hydraulic cable cutters for the most demanding power cable cutting jobs.

The hydraulic cutters in this range are also suitable for cutting such things as guy wires, steel bar, earth rods and steel reinforced overhead conductor. Consult the application selection chart for details.

Spare and replacement blades are available.

THESE TOOLS ARE NOT SUITABLE FOR CUTTING HIGH TENSILE STEEL OR PIANO WIRE.

SPECIFICATION CHART

Cat No.	Style	Oil Vol Required (cc)	Output (tonnes)	Pumping Stages	Head Rotation (deg)	Length (mm)	Weight (kg)
#CCS20A	Hand Operated	-	4	1	180	390	2.8
#CCSP20A	Head only	18	4	-	-	240	2.1
#CCS32	Hand Operated	-	20	1	180	675	9.3
#CCSP32	Head only	135	20	-	-	300	10.0
#CCS40A	Hand Operated	-	6	2	180	580	5.7
#CCSP40A	Head only	48	8	-	-	340	4.0
#CCS55	Hand Operated	-	12	1	180	610	7.9
#CCSP55	Head only	120	12	-	-	415	9.0
#CCS75	Hand Operated	-	2.5	1	360	645	6.3
#CCS85	Hand Operated	-	3	2	180	690	8.7
#CCSP85	Head Only	65	3	-	-	460	7.2
#CCSP100	Head only	140	7.5	-	-	590	13.2

HYDRAULIC CABLE CUTTERS • APPLICATION SELECTION CHART

Cutting Capacity – Maximum diameter (mm)

NOTE: These tools are not suitable for cutting high tensile steel or piano wire

Cat No.	Cu strands	Al strands	CCP (Telephone) Cable	3/4 Core solid sector aluminium	Wire rope 6 x 7	Wire rope 6 x 12	Wire rope 6 x 19	Soft steel bar	Reinforcing rod	ACSR	Guy wire 1 x 7	Guy wire 1 x 19
#CCS20A	20	20	-	-	16	20	20	16	13	21	15	16
#CCSP20A	20	20	-	-	16	20	20	16	13	21	15	16
#CCS32	32	32	-	30	32	32	32	25	25	32	32	32
#CCSP32	32	32	-	30	32	32	32	25	25	32	32	32
#CCS40A	41	41	-	35	22	25	25	20	16	38	15	20
#CCSP40A	41	41	-	35	22	25	25	20	16	38	15	20
#CCS55	55	55	-	50	25	30	30	22	19	50	15	20
#CCSP55	55	55	-	50	25	30	30	22	19	50	15	20
#CCS75	23	29	75	-	-	-	-	-	-	-	-	-
#CCS85	28	38	85	-	-	-	-	-	-	-	-	-
#CCSP85	28	38	85	-	-	-	-	-	-	-	-	-
#CCSP100	42	46	100	-	-	-	-	-	-	-	-	-

[View Parts List](#)



#CCS20A



#CCSP20A



#CCS32



#CCSP32

[View Parts List](#)

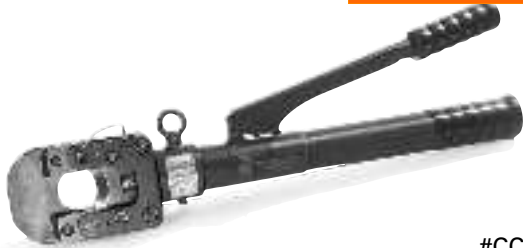

#CCS40A



#CCSP40A

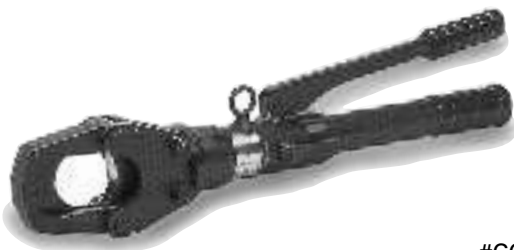

#CCS55



#CCSP55

[View Parts List](#)



#CCS75

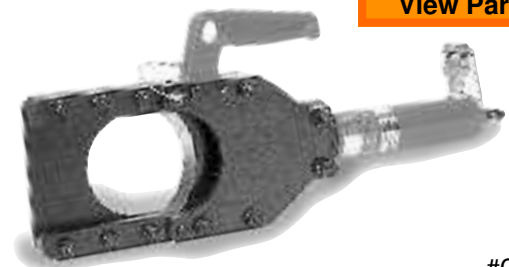

#CCSP100

[View Parts List](#)



#CCS85

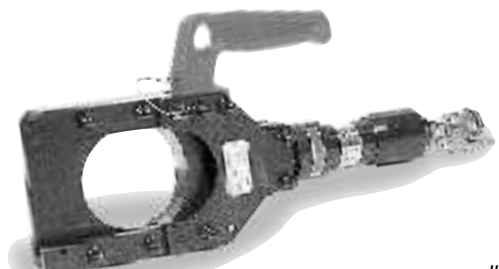

#CCSP85

CABLE STRIPPERS

Safe and easy to use, this innovative range of tools is the ideal solution to a variety of cable stripping applications.

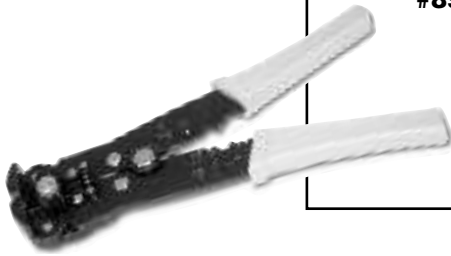

CAT NO.	DESCRIPTION
#89	<p>This easy to use handtool has been developed for stripping insulation from electrical cable. Benefits include alloy steel jaws for stripping wire from 10-26 AWG. Crimps terminals neat and tight. Specially designed light pressure handles. Wire cutter incorporated.</p> <p>RANGE..... 0.13-6mm² LENGTH..... 210mm WEIGHT 300g</p>



CAT NO.	DESCRIPTION
#153	<p>Self adjusting strip and cut tool, with sophisticated 'closed loop' cam mechanism which reduces hand effort and minimises operator fatigue.</p> <p>FEATURES..... Laminated stripping blade avoids damage to fine conductors, Direct driven cutter for powerful but controlled cutting, Fully automatic, no adjustments required for different cable sizes, Repeatable strip lengths, No exposed cutting blades, Smooth profile handles</p> <p>RANGE..... 0.08 to 6.0mm² (stripping) 6.0mm² (max) stranded, 4.0mm² (max) solid</p> <p>SIZE..... 205mm(L) x 19mm(W) x 105mm(H) WEIGHT 200g</p>



CAT NO.	DESCRIPTION
#151	<p>Self adjusting wire stripper and cutter specially designed for flexible cables.</p> <p>FEATURES..... Compact design, pocket sized, Unique design ensures no damage to conductors, Precise rotary action, Integral guillotine wire cutter Safe, no exposed blades, Strips inner & outer insulation</p> <p>RANGE..... Up to 9mm dia cables (stripping) Flexible cables up to 1.5mm² (cutting)</p> <p>SIZE..... 90mm(L) x 18mm(W) x 38mm(H) WEIGHT 35g</p>



CAT NO.	DESCRIPTION
#154	<p>Rotary action power cable stripper for all insulation types (PVC, PE, rubber etc). Two sizes available, 29mm and 40mm.</p> <p>FEATURES..... Triple Action Strip, Easy to achieve 'window' strips, Unique blade profile for difficult insulation such as rubber, Replaceable blades</p> <p>RANGE..... - 4.5mm - 19 to 40mm diameter</p> <p>LENGTH..... - 138mm, 153mm (max) WEIGHT - 100g</p> <p>TRIPLE ACTION SPIRAL CUT</p>

CRIMPING DIES

Utilux crimping dies for aluminium and copper connectors are precision engineered from EN26 high tensile steel, oil hardened to 50-52 Rockwell C, ensuring long life and minimal die wear. Each hexagon die set is engraved with "Utilux" on one of the die faces, and the die part number on the other, leaving an indent on the crimp for easy inspection and verification.

THE RANGE OF DIES INCLUDES:

- Hexagonal die sets for precision crimping of copper and aluminium connectors
 - Nest and indent die sets for special aluminium applications
 - Special 'steel' dies for crimping steel sleeves

The selection of the die type required depends on the connector to be crimped, and the tool to be used.
Special size dies made to order.

'38' SERIES DIE SETS

Suitable for all '12 tonne' hydraulic crimp tools in the Utilux range, as well as the #66H tool.

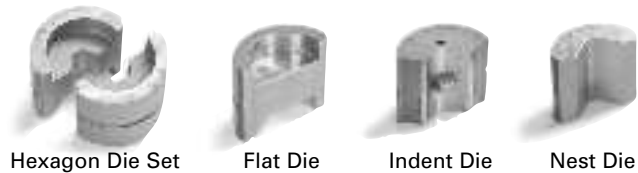

Hexagon Die Set

Flat Die

Indent Die

Nest Die

'40' SERIES DIE SETS

Suitable for the #40B tool, the #40BH tool and their variants.



Hexagon Die Set

'50' SERIES DIE SETS

Suitable for the #50AH tool only



Hexagon Die Set

'66' SERIES DIE SETS

Suitable for the #66H tool only



'111' SERIES DIE SETS

Suitable for the #111, #111H and #111ROBO tools



Mult-faced Hexagon Die Set

'67' AND '70' SERIES DIE SETS

Specially manufactured to order for the #67H and #70H compression heads

DIE HOLDERS

Special die holders are available that allow the use of '38' series dies in the #40B and #50A tools.

#40DH for use the #40B and #40BH tools

#50ADH for use the the #50AH tool



12 TONNE DIES

HEXAGONAL CRIMP DIES – Copper



COPPER CONDUCTOR SIZE (mm ²)	PRECISION	BUDGET	COPPER DIE A/F (mm)
6	38-44CU	CDC6	4.4
10	38-57CU	CDC10	5.7
16	38-63CU	CDC16	6.3
20	38-70CU	CDC20	7.0
25	38-77CU	CDC25	7.7
35	38-92CU	CDC35	9.2
50	38-104CU	CDC50	10.4
70	38-115CU	CDC70	11.5
95	38-142CU	CDC95	14.2
120	38-165CU	CDC120	16.5
150	38-183CU	CDC150	18.3
185	38-200CU	CDC185	20.0
240	38-231CU	CDC240	23.1
300	38-260CU	CDC300	26.0

HEXAGONAL CRIMP DIES – Aluminium



ALUMINIUM CONDUCTOR SIZE (mm ²)	PRECISION	BUDGET	ALUMINIUM DIE A/F (mm)
6 - 35	38-90AL	CDA6/35	9.0
50 - 70	38-132AL	CDA50/70	13.2
95 - 120	38-173AL	CDA95/120	17.3
150 - 185	38-220AL	CDA150/185	22.0
240 - 300	38-284AL	CDA240/300	28.4

INDENT CRIMP DIES – Sector Aluminium



ALUMINIUM CONDUCTOR SIZE (mm ²)	3 CORE		4 CORE	
	NEST DIE	INDENTOR	NEST DIE	INDENTOR
70	#12NEST	#14INDENT	#14NEST	#14INDENT
95	#12NEST	#15INDENT	#14NEST	#15INDENT
120	#12NEST	#16INDENT	#14NEST	#16INDENT
150	#12NEST	#17INDENT	#15NEST	#17INDENT
185	#12NEST	#18INDENT	#15NEST	#18INDENT
240	#12NEST	#19INDENT	#15NEST	#19INDENT
300	#12NEST	#20INDENT	#15NEST	#20INDENT

12 TONNE DIES

HEXAGONAL CRIMP DIES – Half Hex (for flexible cables)



MULTI STRANDED CABLE (mm ²)	DIE SET	HEX DIE	FLAT DIE
16	38-98HHEX17	38-98CU	38-FLAT17
25	38-122HHEX17	38-122CU	38-FLAT17
35	38-130HHEX17	38-130CU	38-FLAT17
50	38-153HHEX17	38-153CU	38-FLAT17
70	38-183HHEX14	38-183CU	38-FLAT14
95	38-220HHEX14	38-220CU	38-FLAT14
120	38-245HHEX14	38-245CU	38-FLAT14

Note: Flat dies are available individually

HEXAGONAL CRIMP DIES – C Connectors

CABLE RANGE (mm ²)	DIE SET	CABLES RANGE (mm ²)	DIE SET
14 - 20	38-T020	99 - 122	38-T122
21 - 26	38-T026	123 - 154	38-T154
27 - 44	38-T044	155 - 190	38-T190
45 - 60	38-T060	191 - 240	38-T240
61 - 76	38-T076	241 - 288	38-T288
77 - 98	38-T098	289 - 365	38-T365

HEXAGONAL CRIMP DIES – Steel cores of ACSR Conductor



DIE SET	DIE A/F (mm)	DIE SET	DIE A/F (mm)
38-74ST13	7.4	38-95ST	9.5
38-76ST	7.6	38-95ST13	9.5
38-80ST	8.0	38-130ST7	13.0

HEXAGONAL CRIMP DIES – Insulated ABC Connectors



ABC CABLE	DIE SET	DIE A/F (mm)
6 - 35	38-140AL9	9.5
25 - 95	38-173AL9	17.3
95 - 150	38-215AL9	21.5

DIES FOR 5 TONNE TOOL



CONDUCTOR	SIZE (mm ²)	HEX DIE	A/F (mm ²)
Copper	10	111-5763CU	5.7
	16		6.3
	25	111-7792CU	7.7
	35		9.2
	50	111-	10.4
	70		11.5
	95	111-	14.2
120	16.5		
Aluminium	6, 10, 16, 25, 35	111-ALSPEC	9.0
	50, 70		13.2
	95, 120		17.3
ABC	MFPB Sleeves	111-	14.0
	25 - 95		17.3
	95 - 150	111-215AL	21.5

DIES FOR 18 TONNE TOOL



CONDUCTOR	SIZE (mm ²)	HEX DIE	A/F (mm ²)
Copper	400	50A-281CU	28
	500	50A-310CU	31
	630	50A-370CU	37
Aluminium	400	50A-390AL	39
	500		

DIES FOR 60 TONNE TOOL



CONDUCTOR	SIZE (mm ²)	HEX DIE	A/F (mm ²)
Copper	70	40-130CU	13.0
	95	40-142CU	14.2
	120	40-165CU	16.5
	150	40-185CU	18.5
	185	40-200CU	20.0
	240	40-231CU	23.1
	300	40-260CU	26.0
	400	40-281CU	28.1
	500	40-310CU	31.0
	630	40-370CU	37.0
	800	40-432CU	43.2
	1000	40-480CU	48.0
Aluminium	95, 120	40-172AL	17.2
	150, 185	40-220AL	22.0
	240, 300	40-283AL	28.3
	400, 500	40-390AL	39.0
	630	40-432AL	43.2

DIES FOR 60 TONNE TOOL

HEXAGONAL CRIMP DIES – Steel Cores of ACSR Conductor

DIE SET	DIE A/F (mm)	DIE SET	DIE A/F (mm)
40-068ST	6.8	40-170ST	17.0
40-95ST	9.5	40-190ST	19.0
40-95ST19	9.5	40-200ST19	20.0
40-140ST19	14.0	40-250ST	25.0
40-160ST	16.0	40-260ST	26.0

#TY SERIES CRIMPING TOOL

LENGTH 381mm • WEIGHT 1.16kg

Available in various crimp groove size combinations. The complete range is adjustable and robust. All models are supplied complete with adjusting key and GO-No Go gauge to ensure a perfect crimp every time.



CAT NO.	CRIMP GROOVE SIZES mm
#TY476556	4.76 and 5.56
#TY476635	4.76 and 6.35
#TY556635	5.56 and 6.35
#TY635794	6.35 and 7.94
#TY556794	5.56 and 7.94

#TR SERIES CRIMPING TOOL

LENGTH 534mm • WEIGHT 2.7kg

This Crimping Tool is available in various crimp groove size combinations. The complete range is adjustable and robust. All models are supplied complete with adjusting key and Go-No Go gauge to ensure a perfect crimp every time.



CAT NO.	CRIMP GROOVE SIZES mm
#TR9521270	9.52 and 12.70
#TR794952	7.94 and 9.52
#TR1588	15.88 (single groove)

CONTENTS



CABLE MANAGEMENT

SECTION 9

SECTION 9	CABLE MANAGEMENT AND ASSOCIATED PRODUCTS	.91
	PIN CLIPS H335B SERIES	.92
	COPPER EARTH RODS	.92
	EARTH CLIPS	.92
	EARTHING STRAPS	.92
	CABLE HOLDERS	.93
	CONDUIT BENDERS	.94
	BATTERY BOOSTER, ALLIGATOR AND TEST CLIPS	.95
	BATTERY BOOSTER CLIPS	.95
	ALLIGATOR CLIPS	.95
	TEST CLIPS	.95
	ALLIGATOR AND TEST CLIP INSULATORS	.95
	STAINLESS STEEL BAND CLAMP & BUCKLES	.96
	SHEATHED BAND CLAMP	.96
	#46 BAND CLAMP TOOL	.96
	NYLON BAND CLAMP	.97
	#117 NYLON BAND FITTING TOOL	.97
	UTI-TIES	.98
	UTI-TIE INSTALLATION TOOL #101	.99
	UTI-TIE INSTALLATION TOOL #TGO9	.99
	UTI-TIE INSTALLATION TOOL #69	.99
	STAINLESS STEEL CABLE TIE TENSIONER #116	.91
	NYLON HOSE	.100



PIN CLIPS

- Manufactured from soft brass, natural finish
- No sharp edges
- Has 12.6mm hardened nail fixed in the pin clip and recessed
- Strips of six for convenient application
- Pin clips are clearly branded and marked with the size number for identification
- H335D brass electro tinned with brass electro tinned pin for use in equatorial areas and marine applications

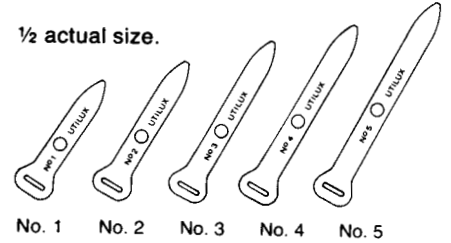

PLAIN	CAT. NO.		MATERIAL	SIZE	LENGTH mm
		PLATED			
H335B#1	H335D#1		Brass with hardened nail	1	38
H335B#2	H335D#2		Brass with hardened nail	2	44
H335B#3	H335D#3		Brass with hardened nail	3	51
H335B#4	H335D#4		Brass with hardened nail	4	57
H335B#5		-	Brass with hardened nail	5	64



COPPER EARTH RODS

CAT. NO.	DESCRIPTION	ROD NOMINAL DIA mm	LENGTH m
CUP1314WC	Domestic – pointed, with clip	13	1.4
CUP1318WC	Domestic – pointed, with clip	13	1.8



EARTH CLIPS

CAT. NO.	MATERIAL	TO SUIT EARTHROD DIA. SIZE mm
H303A#1	Brass	13
H303A#2	Brass	16
H303A#3	Brass	19
H303A#4	Brass	25

EARTHING STRAPS



CAT. NO.	MATERIAL	LENGTH mm
H803A	Brass	101

CABLE HOLDERS

FUNCTION: For securing electrical cable from a diameter of 30mm up to 100mm, to a power pole or beam.

DESIGN FEATURES: The design of the cable holder allows for a variety of sizes of cable, due to the variable adjustment and locking points.

The unique design features of the cable holder are the:

- Dual support legs which allow for dual fixing to a pole
- Optional fixing methods, either using a bolt or bandclamp strapping

MATERIAL: The clamp body is made from mild steel, which has been blanked and formed, then hot-dip galvanised.

- The strap is made from 304 grade stainless steel.
- The pin is zinc diecast.

MARKETS: The clamp has applications in power authorities, mining, railways, building and construction.

ADDITIONAL INFORMATION: A variation to this product is a vertical version, where the fixing points run parallel to the stainless steel strap.

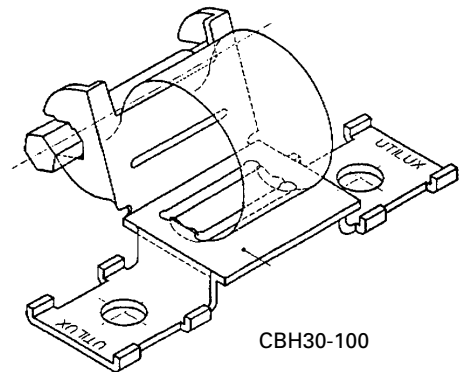

CBH30-100



CBH30-100V

CAT NO.	CABLE	DESCRIPTION
CBH30-100	30-100mm dia	Pole mounted clamp - Horizontal
CBH30-100V	30-100mm dia	Pole mounted clamp - Vertical

CONDUIT BENDERS

The range of Utilux conduit benders are designed for controlled bending of steel conduit and copper pipe without crushing or local deformation occurring.

There are two sizes of bender available, 16mm – 20mm and 25mm. Each bender is made up from two parts, a high strength aluminium head and a galvanised steel handle.



PART NO.	CONDUIT SIZE	DESCRIPTION
AC2071	16-20mm	Head
AC2071H	16-20mm	Handle
AC2081	25mm	Head
AC2071H	25mm	Handle



BATTERY BOOSTER, ALLIGATOR AND TEST CLIPS

BATTERY BOOSTER CLIPS



- All battery clips supplied in equal quantities of positive and negative
 - All clips supplied with handles
 - H811 has a copper shunt between handles
- All clips supplied with copper cable lug, screw and nut

CAT NO.	MATERIAL	MAX. AMPS	JAW OPENING mm
H811	2mm Copper Bronze	200	38
H812	2mm Steel Zinc plated	100	38

ALLIGATOR CLIPS



Utilux Battery Charging Clips have a high standard zinc chromate finish suitable for constant potential or series charging

- All clips feature pan head screw to ensure perfect contact

CAT NO.	DESCRIPTION
H141	Nickel Plated brass 5 amp clip
H2790	Nickel Plated brass 5 amp clip with barrel

TEST CLIPS



CAT NO.	DESCRIPTION
H143	25 amp zinc plated steel test clip
H144	50 amp zinc plated steel test clip
H145	10 amp zinc plated steel test clip
H170	15 amp zinc plated steel test clip

ALLIGATOR AND TEST CLIP INSULATORS



INSULATOR FOR	PACKET OF 6 RED & 6 BLACK	PACKET OF 12 RED	PACKET OF 12 BLACK
H170	H2082		
H143		H2083RD	H2083BK
H144	H2084	H2084RD	H2084BK
H2790	H2796	H2796RD	H2796BK

STAINLESS STEEL BAND CLAMP & BUCKLES

- Versatile • Durable • Ease of handling • Low cost
- BAND AND BUCKLES: • stainless steel minimising corrosion • width: 10, 12, 16, 19mm
- supplied in dispensers of 30m • available in matt finish

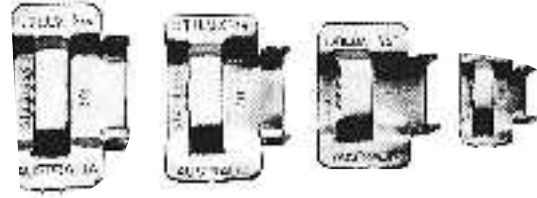

BAND CLAMP – MATT CAT. NO.	WIDTH mm	BUCKLES	TOOLING
H3013M-30	9.5	H3001	#46
H3016M-30	12	H3004	
H3019M-30	16	H3007	
H3022M-30	19	H3010	



SHEATHED BAND CLAMP

- 316 grade stainless steel band clamp
- Coated with halogen free, fire retardant, low smoke compound
 - High strength corrosion resistant strapping
- Ideal for applications where safe evacuation, due to a fire could become hazardous

CAT. NO.	WIDTH mm	THICKNESS mm	COATING mm	BUCKLE	TOOLING
H82400-20	12.7	0.95	0.4	H82401	#115

#46 BAND CLAMP TOOL

- Manufactured from high tensile steel
- Machine threaded tension screw
 - One tool for all band widths



NYLON BAND CLAMP

- Flexible banding system for securing objects of any size
- Made from Nylon 6.6, impervious to atmospheric corrosion and resistant to most solvents and chemicals
 - Cut to any length – reduces inventory and ensures you always have the correct size at hand
- Moulds to the contours of the product for secure grip
 - Temperature range of -40°C to +150°C
 - Available in customer specific colours (min quantity applies)
- Merchandise pack of band & buckles available for 4mm & 7mm
 - Bulk packs of band & buckles available (min quantity applies)



SIZE	TENSILE STRENGTH	BAND		RELEASABLE BUCKLES		PERMANENT BUCKLES	
		P/N	PACK SIZE	P/N	PACK SIZE	P/N	PACK SIZE
4	250Nts	NBC4	25m	-	-	PB4	200
7	500Nts	NBC7	20m	RB7	50, 200	PB7	100
10	1750Nts	NBC10	15m, 80m	RB10	40, 200	-	-

#117 NYLON BAND FITTING TOOL

- Single handed operation
 - Can be used whilst wearing gloves
 - Designed for use at any angle
 - Designed for band teeth to strip if excessive pressure applies
- LENGTH: 270mm • WEIGHT: 500gms



UTI-TIES

- Durable
- Available in natural finish or weather resistant black
- Smooth edges to avoid cuts
- Tapered tip for ease of use
- Self locking system resists slippage

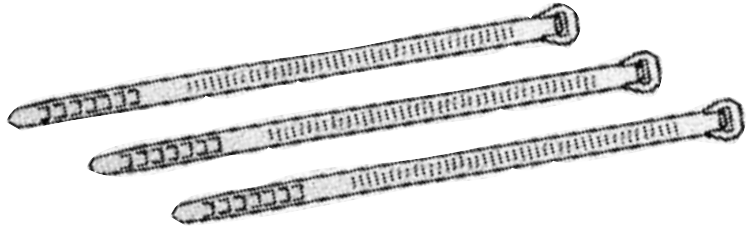

STANDARD NYLON TIES

NATURAL DESCRIPT.	CAT NO.	WEATHER RESISTANT DESCRIPT.	CAT NO.	LENGTH (mm)	WIDTH (mm)	MAX BUNDLE DIA (mm)	TENSILE STRENGTH (KG)	PACK QTY
CT802	H31800	CT802W	H31820	80	2.5	12	8	100/1000
CT1002	H31801	CT1002W	H31821	102	2.5	16	8	100/1000
CT1503	H31802	CT1503W	H31822	150	3.6	32	13	100/1000
CT2004	H31803	CT2004W	H31823	200	4.8	44	22	100/1000
CT3004	H31804	CT3004W	H31824	300	4.8	76	22	100/1000
CT3704	H31806	CT3704W	H31826	370	4.8	102	22	100/1000

HEAVY DUTY NYLON TIES

NATURAL DESCRIPT.	WEATHER RESISTANT DESCRIPT.	LENGTH (mm)	WIDTH (mm)	MAX BUNDLE DIA (mm)	TENSILE STRENGTH (KG)	PACK QTY
CT3807	CT3807W	380	7.6	102	54	100/1000
	CT5507W	550	7.6	160	54	100/1000

EXTRA HEAVY DUTY NYLON TIES

DESCRIPT.	LENGTH (mm)	WIDTH (mm)	MAX BUNDLE DIA (mm)	TENSILE STRENGTH (KG)	PACK QTY
CT55012W	550	12.7	160	110	100

STAINLESS STEEL CABLE TIES

DESCRIPT.	LENGTH (mm)	WIDTH (mm)	MAX BUNDLE DIA (mm)	TENSILE STRENGTH (KG)	PACK QTY
CT2004SS	200	4.6	50	44	10/100
CT3604SS	360	4.6	100	44	10/100
CT5204SS	520	4.6	150	44	10/100
CT6804SS	680	4.6	200	44	10/100

STAINLESS STEEL CABLE TIES – HEAVY DUTY

DESCRIPT.	LENGTH (mm)	WIDTH (mm)	MAX BUNDLE DIA (mm)	TENSILE STRENGTH (KG)	PACK QTY
CT2008SS	200	8	50	111	50
CT3608SS	360	8	100	111	50

CABLE TIE MOUNTS - 4 WAY

DESCRIPT.	LENGTH (mm)	WIDTH (mm)	HEIGHT	PACK QTY
TM19194	19	19	4	100
TM28284	28	28	4	100

UTI-TIE INSTALLATION TOOL #101

DESCRIPTION

FEATURES Budget, Light weight
 RANGE Suitable for 2 to 5mm wide Uti-Ties
 SIZE 175mm
 WEIGHT 60g

UTI-TIE INSTALLATION TOOL #TG9

DESCRIPTION

FEATURES Heavy duty steel, manual cut off
 RANGE Suitable for 2.5 to 10mm wide Uti Ties
 SIZE 190mm
 WEIGHT 320g

UTI-TIE INSTALLATION TOOL #69

DESCRIPTION

FEATURES Robust, Tension adjusting dial, auto cut off
 RANGE Suitable for 2 to 4.8mm wide Uti-Ties
 SIZE 165mm
 WEIGHT 210g

STAINLESS STEEL CABLE TIE TENSIONER #116

DESCRIPTION

FEATURES Manual cut off
 RANGE Suitable for all stainless steel ties
 SIZE 210mm
 WEIGHT 570g

NYLON HOSE CLIPS



DESCRIPTION

- World acclaimed hose fastening system
- One piece, durable Nylon 66 moulding
- High integrity clamping by double row of interlocking teeth
- Fast easy fitting and release
- High resistance to corrosion and solvent attack
- 200psi clamp force with only 3 teeth engaged

PART NO.	HOSE DIAMETER			BAND WIDTH	REF NO.
	MIN	MAX	OPTIMUM		
HCN7	5.6	6.8	6.5	4.2	A
HCN8	6.5	8.1	7.9	4.5	AA
HCN9	7.9	9.6	9.2	4.4	B
HCN10	9.2	10.8	10.3	4.5	BB
HCN12	10.2	12.3	11.8	5.8	C
HCN13	11.1	13.4	12.9	6.1	CC
HCN14	12.0	14.5	13.8	6.1	D
HCN15	13.1	15.7	15.1	7.2	E
HCN17	15.0	17.8	17.1	7.1	F
HCN19	16.9	19.9	19.1	6.9	G
HCN21	18.1	21.4	20.6	7.1	H
HCN23	20.3	23.7	23.0	6.4	J
HCN25	22.2	25.8	24.9	7.0	K
HCN28	24.5	28.4	27.6	7.1	L
HCN30	26.5	30.4	29.5	7.4	M
HCN32	28.8	33.0	32.2	9.0	N
HCN35	32.0	35.6	34.8	9.1	P
HCN38	34.3	38.7	37.9	8.9	Q

Complete range of Clips to suit hose diameters from 5.6mm to 171mm. Refer to Tyco Sales Department for full listing.



CONTENTS

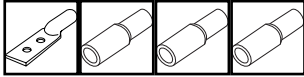

TECHNICAL DATA

SECTION 10

SECTION 10 UTILUX EXPRESS REFERENCE

TABLES TOOL SELECTION CHARTS101
UTILUX EXPRESS ORDER FORMS102
CONVERSION TABLES FOR NON-METRIC CABLE SIZES108
USEFUL REFERENCE TABLES109
COMPRESSION TERMINATION THEORY119
BASIC COMPRESSION TERMINATION PRACTICES119
TERMINATION RECOMMENDATIONS119
FLEXIBLE CABLE CRIMPING120
METRIC DESCRIPTION122
ERGONOMIC DESIGN –123



1. Tick a box to identify the standard blank which is closest to your required design.
2. Complete the Conductor Details section inserting your requirements.
3. Enter your required dimensions staying within the guidelines in the standards table.
4. Complete customer contact and authorisation details.
5. Fax to Utilux Express.

COPPER LUGS

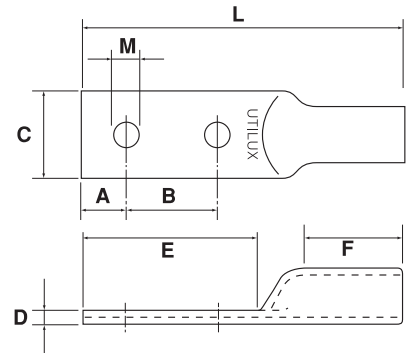
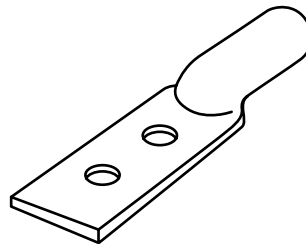

I. STANDARDS & GUIDELINES

All dimensions in mm

	Catalogue No.	Conductor Range mm ²	A Min	B Max	C Ref	D Ref	E Max	F Max	L Max	M Max
<input type="checkbox"/>	CGX25/I	25	8.0	54	16.7	1.9	70	40	115	M10
<input type="checkbox"/>	CGX35/I	35	8.0	74	18.2	2.7	90	45	140	M12
<input type="checkbox"/>	CGX50/I	50	11.0	78	20.6	2.8	100	50	159	M12
<input type="checkbox"/>	CGX70/I	70	11.0	78	21.0	3.2	100	50	161	M12
<input type="checkbox"/>	CGX 95/I	95	12.0	76	25.0	4.0	100	50	163	M12
<input type="checkbox"/>	CGX120/I	120	15.0	70	30.0	4.8	100	50	165	M20
<input type="checkbox"/>	CGX150/I	150	18.0	64	34.0	5.4	100	50	166	M20
<input type="checkbox"/>	CGX185/I	185	18.0	64	37.0	5.2	100	55	173	M20
<input type="checkbox"/>	CGX240/I	240	23.0	64	42.0	7.1	110	60	191	M20
<input type="checkbox"/>	CGX300/I	300	23.0	64	46.0	7.9	110	60	192	M20
<input type="checkbox"/>	CGX400/I	400	23.0	64	49.6	7.9	110	70	207	M20
<input type="checkbox"/>	CGX500/I	500	23.0	64	54.8	8.2	110	70	213	M20
<input type="checkbox"/>	CGX630/I	630	25.0	50	63.5	11.5	100	70	205	M20

2. CONDUCTOR DETAILS

3. REQUIRED SPECIFICATIONS

Stranding: _____

Area: _____ mm²

Type: Flexible

Solid

Stranded

Compacted

Dimensions: A: _____ mm B: _____ mm² E: _____ mm

F: _____ mm L: _____ mm Stud M: _____ mm

Qty: _____

Comments _____

4. CUSTOMER DETAILS

Company _____

Email Contact _____

Telephone _____

Facsimile _____

Order No. _____ Date _____

Date Required _____

Approved By _____

Approval Signature _____

5. Print & Fax this to UTILUX EXPRESS - (02) 4353 2470 [Print Order](#)

Specially manufactured products cannot be returned for credit.



COPPER LINKS

1. Tick a box to identify the standard blank which is closest to your required design.
2. Complete the Conductor Details section inserting your requirements.
3. Enter your required dimensions staying within the guidelines in the standards table.
4. Complete customer contact and authorisation details.
5. Fax to Utilux Express.

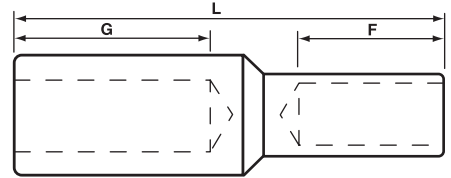
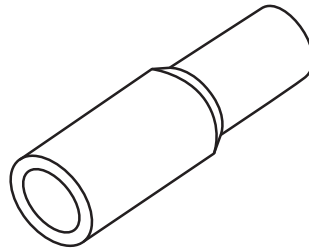

I. STANDARDS & GUIDELINES All dimensions in mm

Catalogue No.	Conductor Range mm ²	F Recommended Lengths	G
<input type="checkbox"/> CKX10-35/I	10-35	24	24
<input type="checkbox"/> CKX50-70/I	50-70	24	24
<input type="checkbox"/> CKX95-120/I	95-120	38	38
<input type="checkbox"/> CKX150-185/I	150-185	38	38
<input type="checkbox"/> CKX240-300/I	240-300	44	44
<input type="checkbox"/> CKX400-500/I	400-500	59	59
<input type="checkbox"/> CKX630/I	630	59	59

2. CONDUCTOR DETAILS ➡ 3. REQUIRED SPECIFICATIONS

LARGE END Stranding: _____ Area : _____mm ² Type: Flexible <input type="checkbox"/> Solid <input type="checkbox"/> Stranded <input type="checkbox"/> Compacted <input type="checkbox"/>	SMALL END Stranding: _____ Area: _____mm ²	Dimensions: F: _____mm G: _____mm Qty: _____ Comments _____ _____
---	--	--

4. CUSTOMER DETAILS

Company _____	Order No. _____	Date _____
Email Contact _____	Date Required _____	
Telephone _____	Approved By _____	
Facsimile _____	Approval Signature _____	

5. Print & Fax this to **UTILUX EXPRESS - (02) 4353 2470** Print Order

Specially manufactured products cannot be returned for credit.



1. Tick a box to identify the standard blank which is closest to your required design.
2. Complete the Conductor Details section inserting your requirements.
3. Enter your required dimensions staying within the guidelines in the standards table.
4. Complete customer contact and authorisation details.
5. Fax to Utilux Express.

BI-METAL LINKS

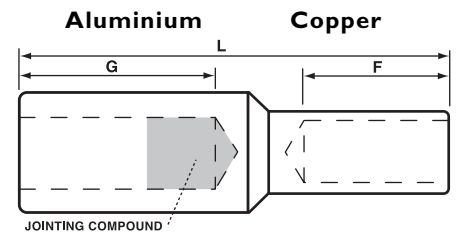
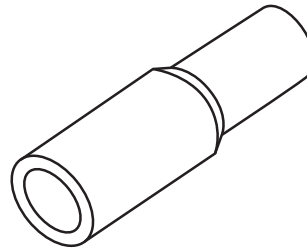

I. STANDARDS & GUIDELINES All dimensions in mm

Catalogue No.	Conductor Range mm ²	F Max	G Max	L Max
<input type="checkbox"/> BKX10-35/I	10-35	21.5	32	70
<input type="checkbox"/> BKX50-70/I	50-70	21.5	32	70
<input type="checkbox"/> BKX95-120/I	95-120	40	60	120
<input type="checkbox"/> BKX150-185/I	150-185	40	60	120
<input type="checkbox"/> BKX240-300/I	240-300	40	60	120
<input type="checkbox"/> BKX400-630/I	400-630	60	70	160

2. CONDUCTOR DETAILS 3. REQUIRED SPECIFICATIONS

LARGE END Material: Al Stranding: _____ Area : _____mm ²	SMALL END Material: Cu Stranding: _____ Area: _____mm ²	Dimensions: F: _____mm G: _____mm Qty: _____ Comments _____ _____ _____
Type: Flexible <input type="checkbox"/> Solid <input type="checkbox"/> Stranded <input type="checkbox"/> Compacted <input type="checkbox"/>		

4. CUSTOMER DETAILS

Company _____	Order No. _____	Date _____
Email Contact _____	Date Required _____	
Telephone _____	Approved By _____	
Facsimile _____	Approval Signature _____	

5. Print & Fax this to **UTILUX EXPRESS - (02) 4353 2470** Print Order

Specially manufactured products cannot be returned for credit.



ALUMINIUM LINKS

1. Tick a box to identify the standard blank which is closest to your required design.
2. Complete the Conductor Details section inserting your requirements.
3. Enter your required dimensions staying within the guidelines in the standards table.
4. Complete customer contact and authorisation details.
5. Fax to Utilux Express.

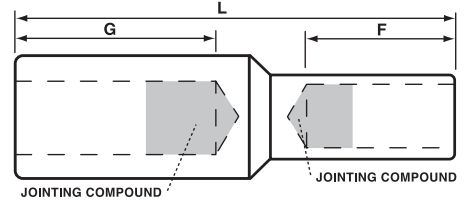
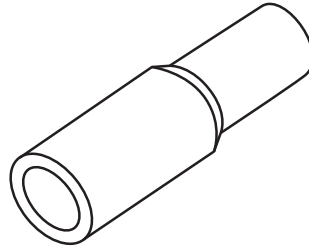

I. STANDARDS & GUIDELINES All dimensions in mm

Catalogue No.	Conductor Range mm ²	F Recommended Lengths	G
<input type="checkbox"/> AKX10-35/I	10-35	32	32
<input type="checkbox"/> AKX50-70/I	50-70	32	32
<input type="checkbox"/> AKX95-120/I	95-120	60	60
<input type="checkbox"/> AKX150-185/I	150-185	60	60
<input type="checkbox"/> AKX240-300/I	260-300	60	60
<input type="checkbox"/> AKX400-630/I	400-630	70	70

2. CONDUCTOR DETAILS ▶ 3. REQUIRED SPECIFICATIONS

LARGE END	SMALL END	Dimensions: F: _____ mm G: _____ mm
Stranding: _____	Stranding: _____	Qty: _____
Area: _____ mm ²	Area: _____ mm ²	Comments
Type: Flexible <input type="checkbox"/>		_____
Solid <input type="checkbox"/>		_____
Stranded <input type="checkbox"/>		
Compacted <input type="checkbox"/>		

4. CUSTOMER DETAILS

Company _____	Order No. _____	Date _____
Email Contact _____	Date Required _____	
Telephone _____	Approved By _____	
Facsimile _____	Approval Signature _____	

5. Print & Fax this to **UTILUX EXPRESS - (02) 4353 2470** Print Order

Specially manufactured products cannot be returned for credit.



1. Tick a box to identify the standard blank which is closest to your required design.
2. Complete the Conductor Details section inserting your requirements.
3. Enter your required dimensions staying within the guidelines in the standards table.
4. Complete customer contact and authorisation details.
5. Fax to Utilux Express.

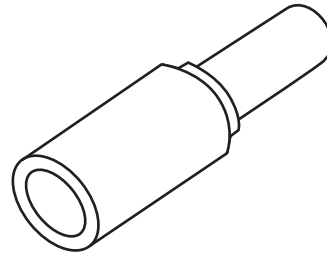

BI-METAL STALK LUGS

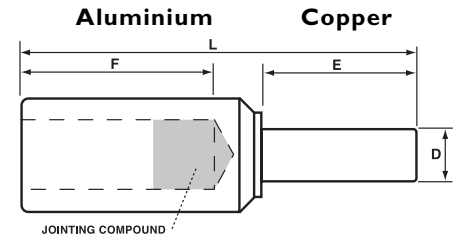

I. STANDARDS & GUIDELINES All dimensions in mm

Catalogue No.	Conductor Range mm ²	D Max	E Max	F Max	L Max
<input type="checkbox"/> BSX10-35/I	10-35	12	30	32	70
<input type="checkbox"/> BSX50-70/I	50-70	16	30	32	70
<input type="checkbox"/> BSX95-120/I	95-120	22	50	60	120
<input type="checkbox"/> BSX150-185/I	150-185	26	50	60	120
<input type="checkbox"/> BSX240-300/I	240-300	33	50	60	120
<input type="checkbox"/> BSX400-630/I	400-630	45	70	70	160

2. CONDUCTOR DETAILS 3. REQUIRED SPECIFICATIONS

LARGE END Material: Al Stranding: _____ Area : _____mm ² Type: Flexible <input type="checkbox"/> Solid <input type="checkbox"/> Stranded <input type="checkbox"/> Compacted <input type="checkbox"/>	SMALL END Material: Cu Diameter : _____mm	Dimensions: D: _____mm E: _____mm F: _____mm Qty: _____ Comments _____ _____ _____
--	---	---

4. CUSTOMER DETAILS

Company _____	Order No. _____	Date _____
Email Contact _____	Date Required _____	
Telephone _____	Approved By _____	
Facsimile _____	Approval Signature _____	

5. Print & Fax this to **UTILUX EXPRESS - (02) 4353 2470** Print Order

Specially manufactured products cannot be returned for credit.



COPPER STALK LUGS

1. Tick a box to identify the standard blank which is closest to your required design.
2. Complete the Conductor Details section inserting your requirements.
3. Enter your required dimensions staying within the guidelines in the standards table.
4. Complete customer contact and authorisation details.
5. Fax to Utilux Express.

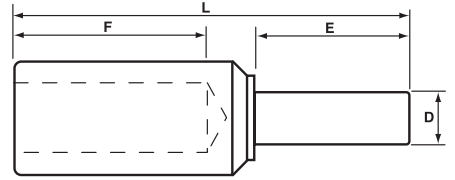
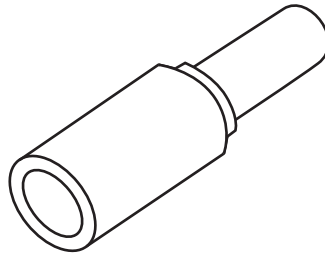

I. STANDARDS & GUIDELINES All dimensions in mm

Catalogue No.	Conductor Range mm ²	D Max	E Max	F Recommended
<input type="checkbox"/> CSX10-35/I	10-35	12	50	21.5
<input type="checkbox"/> CSX50-70/I	50-70	16	50	21.5
<input type="checkbox"/> CSX95-120/I	95-120	22	50	35
<input type="checkbox"/> CSX150-185/I	150-185	26	70	35
<input type="checkbox"/> CSX240-300/I	240-300	33	90	50
<input type="checkbox"/> CSX400-500/I	400-500	39	100	60

2. CONDUCTOR DETAILS ▶ 3. REQUIRED SPECIFICATIONS

LARGE END Material: Cu Stranding: _____ Area : _____mm ² Type: Flexible <input type="checkbox"/> Solid <input type="checkbox"/> Stranded <input type="checkbox"/> Compacted <input type="checkbox"/>	SMALL END Material: Cu Diameter: _____mm	Dimensions: D: _____mm E: _____mm F: _____mm Qty: _____ Comments _____ _____ _____
--	--	---

4. CUSTOMER DETAILS

Company _____	Order No. _____	Date _____
Email Contact _____	Date Required _____	
Telephone _____	Approved By _____	
Facsimile _____	Approval Signature _____	

5. Print & Fax this to **UTILUX EXPRESS - (02) 4353 2470** Print Order

Specially manufactured products cannot be returned for credit.

CONVERSION TABLES FOR NON-METRIC CABLE SIZES

BRITISH STANDARD WIRE GAUGE SWG	METRIC EQUIVALENT (sqmm)
33	0.0507
32	0.0591
31	0.0682
30	0.0779
29	0.0937
28	0.0111
27	0.0136
26	0.0164
25	0.0203
24	0.0245
23	0.0292
22	0.0397
21	0.0519
20	0.0657
19	0.81
18	1.17
17	1.59
16	2.08
15	2.63
14	3.24
13	4.29
12	5.48
10	8.30

IMPERIAL (sqIN)	METRIC EQUIVALENT (sqmm)
0.001	0.657
0.0015	0.981
0.002	1.28
0.003	1.97
0.0032	2.08
0.0045	2.98
0.007	4.60
0.01	6.81
0.0145	9.59
0.0225	14.5
0.03	18.6
0.04	26.0
0.06	39.4
0.075	49.9
0.1	66.3
0.12	76.8
0.15	97.2
0.2	129
0.25	162
0.3	199
0.4	267
0.5	328
0.6	399
0.75	489
0.85	557
1.0	683
1.25	807
1.5	1050

AMERICAN WIRE GAUGE AWG	METRIC EQUIVALENT (sqmm)	AMERICAN WIRE GAUGE AWG	METRIC EQUIVALENT (sqmm)
30	0.0507	250 MCM	127
29	0.0645	300 MCM	152
28	0.0806	350 MCM	177
27	0.102	400 MCM	203
26	0.128	450 MCM	228
25	0.163	500 MCM	253
24	0.205	550 MCM	279
23	0.259	600 MCM	304
22	0.324	650 MCM	329
21	0.412	700 MCM	355
20	0.519	750 MCM	380
19	0.652	800 MCM	405
18	0.826	850 MCM	431
17	1.04	900 MCM	456
16	1.31	950 MCM	481
15	1.65	1000 MCM	507
14	2.08	1100 MCM	557
13	2.63	1200 MCM	608
12	3.31	1300 MCM	659
11	4.17	1400 MCM	709
10	5.26	1500 MCM	760
9	6.63	1600 MCM	811
8	8.37	1700 MCM	861
7	10.6	1800 MCM	912
6	13.3	1900 MCM	963
5	16.8	2000 MCM	1010
4	21.2		
3	26.7		
2	33.6		
1	42.4		
0	53.5		
2/0	67		
3/0	85		
4/0	107		

USEFUL REFERENCE TABLES

APPENDIX A

FITTINGS FOR BARE OVERHEAD ALL ALUMINIUM CONDUCTORS (AAC)

CODE NAME	STRAND	NON TENSION		FULL TENSION		JUMPER		ALUMINIUM LUG		ALUMINIUM LUG		TERM. ADAPTOR		BI-METAL LUG	
		SLEEVE	DIE	SLEEVE	DIE	SLEEVE	DIE	1 HOLE	DIE	2 HOLE	DIE	TYPE	DIE		DIE
Gemini	7/1.75	NT36	38-132AL	FT36A	38-132AL	JS36R	38-132AL	SL36	38-132AL	AL36	38-132AL	BA36	38-132AL	H15304	38-90AL
Jupiter	7/2.25	NT36	38-140AL	FT36A	38-140AL	JS36R	38-140AL	SL36	38-140AL	AL36	38-140AL	BA36	38-140AL	H15306	38-90AL
Leo	7/2.50	NT36	38-140AL	FT36A	38-140AL	JS36R	38-140AL	SL36	38-140AL	AL36	38-140AL	BA36	38-140AL	H15308	38-90AL
Leondis	7/2.75	NT44	38-173AL	FT44A	38-173AL	JS44R	38-173AL	SL44	38-173AL	AL44	38-173AL			H15308	38-90AL
Libra	7/3.00	NT44	38-180AL	FT44A	38-180AL	JS44R	38-180AL	SL44	38-180AL	AL44	38-180AL			H15311	38-132AL
Mars	7/3.75	NT50	38-180AL	FT50A	38-180AL	JS50R	38-180AL	SL50	38-180AL	AL50	38-180AL	BA50	38-180AL	H15317	38-173AL
Mercury	7/4.50	NT58	38-190AL	FT58A	38-190AL	JS58R	38-190AL	SL58	38-190AL	AL58	38-190AL	BA58	38-190AL	H15320	38-173AL
Mercury	7/4.50	NT61	38-220AL	FT61A	38-220AL	JS61R	38-220AL	SL61	38-220AL	AL61	38-220AL	BA61	38-220AL	H15320	38-173AL
Moon	7/4.75	NT61	38-220AL	FT61A	38-220AL	JS61R	38-220AL	SL61	38-220AL	AL61	38-220AL	BA61	38-220AL	H15320	38-173AL
Neptune	19/3.25	NT68	38-220AL	FT68A	38-220AL	JS68R	38-220AL	SL68	38-220AL	AL68	38-220AL	BA68	38-220AL	H15323	38-220AL
Orion	19/3.50	NT80	38-250AL	FT80A	38-250AL	JS80R	38-250AL	SL80	38-250AL	AL80	38-250AL	BA80	38-250AL	H15326	38-220AL
Pluto	19/3.75	NT80	38-262AL	FT80A	38-262AL	JS80R	38-262AL	SL80	38-262AL	AL80	38-262AL	BA80	38-262AL	H15329	38-284AL
Saturn	37/3.00	NT94	38-284AL	FT94A	38-284AL	JS94R	38-284AL	SL94	38-284AL	AL94	38-284AL			H15332	38-284AL
Sirius	37/3.25	NT94	38-284AL	FT94A	38-284AL	JS94R	38-284AL	SL94	38-284AL	AL94	38-284AL			H15332	38-284AL
Taurus	19/4.75	NT94	38-303AL	FT94A	38-303AL	JS94R	38-303AL	SL94	38-303AL	AL94	38-303AL			H15334	38-390AL
Triton	37/3.75	NT114	40-432AL	FT114A	40-432AL										

FITTINGS FOR BARE OVERHEAD ALUMINIUM CONDUCTORS STEEL REINFORCED (ACSR)

CODE NAME	STRAND	NON TENSION		FULL TENSION		JUMPER		ALUMINIUM LUG		ALUMINIUM LUG		TERM. ADAPTOR		BI-METAL LUG	
		SLEEVE	DIE	SLEEVE	DIE	SLEEVE	DIE	1 HOLE	DIE	2 HOLE	DIE	TYPE	DIE		DIE
Quince	3/4/1.75	NT36	38-132AL			JS36R	38-132AL	SL36	38-132AL	AL36	38-132AL	BA36	38-132AL	H15304	38-90AL
Almond	6/1/2.50	NT36	38-140AL			JS36R	38-140AL	SL36	38-140AL	AL36	38-140AL	BA36	38-140AL	H15308	38-90AL
Raisin	3/4/2.50	NT36	38-140AL			JS36R	38-140AL	SL36	38-140AL	AL36	38-140AL	BA36	38-140AL	H15308	38-90AL
Apricot	6/1/2.75	NT44	38-173AL	FT44R	38-173AL	JS44R	38-173AL	SL44	38-173AL	AL44	38-173AL	BA44	38-173AL	H15308	38-90AL
Apple	6/1/3.00	NT44	38-173AL	FT44R	38-173AL	JS44R	38-173AL	SL44	38-173AL	AL44	38-173AL	BA44	38-173AL	H15311	38-132AL
Sultana	4/3/3.00	NT44	38-180AL			JS44R	38-180AL	SL44	38-180AL	AL44	38-180AL	BA44	38-180AL	H15311	38-132AL
Banana	6/1/3.75	NT50	38-180AL	FT50R	38-180AL	JS50R	38-180AL	SL50	38-180AL	AL50	38-180AL	BA50	38-180AL	H15317	38-173AL
Walnut	4/3/3.75	NT50	38-180AL			JS50R	38-180AL	SL50	38-180AL	AL50	38-180AL	BA50	38-180AL	H15317	38-173AL
Cherry	6/4.75 7/1.60	NT61	38-220AL	FT61R	38-220AL	JS61R	38-220AL	SL61	38-220AL	AL61	38-220AL	BA61	38-220AL	H15320	38-173AL
Grape	30/7/2.50	NT80	38-250AL			JS80R	38-250AL	SL80	38-250AL	AL80	38-250AL			H15326	38-220AL
Fig	18/1/3.50	NT80	38-250AL			JS80R	38-250AL	SL80	38-250AL	AL80	38-250AL			H15326	38-220AL
Lemon	30/7/3.00	NT94	38-284AL												

USEFUL REFERENCE TABLES

AUSTRALIAN STANDARD METRIC CONDUCTORS

ACSR/AC – ALUMINIUM CONDUCTOR (ALUMINIUM CLAD) STEEL REINFORCED.

Aust. Standard – AS1220 PART 3

CODE NAME	STRANDS/ WIRE DIAMETER mm	OVERALL DIAMETER (APPROX) mm	CALCULATED EQUIVALENT ALUMINIUM AREA mm ²	SECTIONAL AREA mm ²	CALCULATED MINIMUM BREAKING LOAD kN	APPROXIMATE MASS PER KM kg
Angling	6/1/2.50	7.50	30.7	34.36	10.7	113
Archery	6/1/3.00	9.00	44.1	49.48	15.0	163
Baseball	6/1/3.75	11.3	68.9	77.31	22.4	255
Bowls	6/4.75+7/1.60	14.3	109	120.4	32.6	385
Cricket	30/7/2.50	17.5	155	181.6	64.6	635
Darts	30/7/3.00	21.0	224	261.5	91.3	913
Diving	30/7/3.50	24.5	305	356.0	121	1240
Golf	54/7/3.00	27.0	390	431.2	119	1380
Gymnastics	54/7/3.25	29.3	457	506.0	138	1620
Hurdles	54/7/3.50	31.5	530	586.9	159	1880
Lacrosse	54/3.75+19/2.25	33.8	608	671.7	181	2150
Rugby	54/4.75+19/2.85	42.8	976	1078	287	3450
EXTRA HIGH STRENGTH						
Skating	3/4/1.75	5.25	10.4	16.84	12.3	83.5
Soccer	3/4/2.50	7.50	21.2	34.36	24.9	170
Swimming	4/3/3.00	9.00	35.2	49.48	28.8	217
Tennis	4/3/3.75	11.3	54.9	77.31	42.8	339



USEFUL REFERENCE TABLES

AUSTRALIAN STANDARD METRIC CONDUCTORS

AAC – ALL ALUMINIUM CONDUCTOR

Aust. Standard – AS1531 PART 1

CODE NAME	STRANDS/ WIRE DIAMETER mm	OVERALL DIAMETER (APPROX) mm	CALCULATED EQUIVALENT ALUMINIUM AREA mm ²	SECTIONAL AREA mm ²	CALCULATED MINIMUM BREAKING LOAD kN	APPROXIMATE MASS PER KM kg
Gemini	7/1.75	5.25	16.6	16.84	3.01	46.1
Jupiter	7/2.25	6.75	27.5	27.83	4.76	75.9
Leo	7/2.50	7.50	33.9	34.36	5.75	94.3
Libra	7/3.00	9.00	48.8	49.48	7.91	135
Mars	7/3.75	11.3	76.3	77.31	11.9	212
Mercury	7/4.50	13.5	110	111.3	16.8	305
Moon	7/4.75	14.3	122	124.0	18.8	340
Neptune	19/3.25	16.3	155	157.6	24.7	433
Pluto	19/3.75	18.8	206	209.8	32.3	578
Saturn	37/3.00	21.0	256	261.5	41.8	721
Taurus	19/4.75	23.8	331	336.7	50.9	926
Triton	37/3.75	26.3	400	408.7	62.9	1130
Uranus	61/3.25	29.3	493	506.0	75.2	1400
Venus	61/3.75	33.8	659	673.7	98.3	1860
Virgo	91/4.50	49.5	1410	1447	207	4010

AAAC – ALL ALUMINIUM ALLOY CONDUCTOR

Aust. Standard – AS1531 PART 2

CODE NAME	STRANDS/ WIRE DIAMETER mm	OVERALL DIAMETER (APPROX) mm	CALCULATED EQUIVALENT ALUMINIUM AREA mm ²	SECTIONAL AREA mm ²	CALCULATED MINIMUM BREAKING LOAD kN	APPROXIMATE MASS PER KM kg
Agate	7/1.75	5.25	14.3	16.84	4.71	46.1
Amethyst	7/2.25	6.75	23.7	27.83	7.78	75.9
Diamond	7/2.50	7.50	29.3	34.36	9.64	94.3
Emerald	7/3.00	9.00	42.1	49.48	13.9	135
Garnet	7/3.75	11.3	65.8	77.31	21.7	211
Jade	7/4.50	13.5	94.8	111.3	31.2	304
Jasper	7/4.75	14.3	106	124.0	34.8	339
Opal	19/3.25	16.3	134	157.6	44.2	433
Pearl	19/3.75	18.8	178	209.8	58.8	576
Ruby	37/3.00	21.0	221	261.5	73.5	721
Rutile	19/4.75	23.8	285	336.7	94.4	924
Sapphire	37/3.75	26.3	345	408.7	115	1120
Spinel	61/3.25	29.3	426	506.0	135	1400
Topaz	61/3.75	33.8	568	673.7	179	1860
Zircon	91/4.50	49.5	1220	1447	384	4000

USEFUL REFERENCE TABLES

AUSTRALIAN STANDARD METRIC CONDUCTORS

SC/GZ – STEEL CONDUCTOR/GALVANISED

Aust. Standard – AS1222 PART 1

STRANDS/WIRE DIAMETER /mm	OVERALL DIAMETER (APPROX) mm	CALCULATED EQUIV. ALUMINIUM AREA mm ²	SECTIONAL AREA mm ²	CALCULATED MIN. BREAKING LOAD kN	APPROXIMATE MASS PER Km kg
3/2.00	4.31	1.56	9.425	11.7	75.5
3/2.75	5.93	2.95	17.82	22.2	139
7/2.00	6.00	3.62	21.99	27.4	177
7/2.75	8.25	6.85	41.58	51.8	326
7/3.25	9.75	9.56	58.07	72.3	460
7/3.75	11.3	12.7	77.31	96.2	609
19/2.00	10.0	9.79	59.69	74.4	483
19/2.75	13.8	18.5	112.9	141.0	888
19/3.25	16.3	25.8	157.6	196.0	1250

SC/AC – STEEL CONDUCTOR/ALUMINIUM CLAD

Aust. Standard – AS1222 PART 2

STRANDS/WIRE DIAMETER /mm	OVERALL DIAMETER (APPROX) mm	CALCULATED EQUIV. ALUMINIUM AREA mm ²	SECTIONAL AREA mm ²	CALCULATED MIN. BREAKING LOAD kN	APPROXIMATE MASS PER Km kg
3/2.75	5.93	5.91	17.82	22.7	118
3/3.00	6.47	7.03	21.21	27.0	141
3/3.25	7.00	8.26	24.89	31.6	165
3/3.75	8.08	11.0	33.13	40.0	220
7/2.75	8.25	13.7	41.58	50.1	277
7/3.00	9.00	16.3	49.48	59.7	330
7/3.25	9.75	19.2	58.07	69.8	387
7/3.75	11.3	25.5	77.31	88.3	515
7/4.25	12.8	32.8	99.3	106	662
19/2.75	13.8	37.1	112.9	136	755
19/3.00	15.0	44.1	134.3	162	899
19/3.25	16.3	51.8	157.6	189	1060
19/3.75	18.8	68.9	209.8	240	1410
19/4.25	21.3	88.6	269.5	289	1800

HDC – HARD DRAWN COPPER CONDUCTOR

Aust. Standard – AS1746 1975

STRANDS/WIRE DIAMETER /mm	OVERALL DIAMETER (APPROX) mm	CALCULATED EQUIV. ALUMINIUM AREA mm ²	SECTIONAL AREA mm ²	CALCULATED MIN. BREAKING LOAD kN	APPROXIMATE MASS PER Km kg
7/1.00	3.00	8.68	5.498	2.31	49.3
7/1.25	3.75	13.6	8.589	3.61	76.9
7/1.75	5.25	26.6	16.84	6.89	151
7/2.00	6.00	34.7	21.99	9.02	197
7/2.75	8.25	65.3	41.58	16.7	375
7/3.50	10.5	106	67.35	26.6	607
19/1.75	8.75	71.7	45.70	18.3	413
19/2.00	10.0	93.7	59.69	23.9	538
19/2.75	13.8	177	112.9	44.5	1020
19/3.00	15.0	211	134.3	52.8	1210
37/1.75	12.3	139	89.0	35.6	806
37/2.50	17.5	284	181.6	72.9	1640
37/2.75	19.3	344	219.8	86.6	1990
37.3.00	21.0	409	261.5	103	2370
61/2.75	24.8	566	362.3	143	3280

USEFUL REFERENCE TABLES

AUSTRALIAN STANDARD METRIC CONDUCTORS

ACSR/GZ – ALUMINIUM CONDUCTOR (GALVANISED) STEEL REINFORCED.

Aust. Standard – AS1220 PART 1

CODE NAME	STRANDS/ WIRE DIAMETER mm	OVERALL DIAMETER (APPROX) mm	CALCULATED EQUIVALENT ALUMINIUM AREA mm ²	SECTIONAL AREA mm ²	CALCULATED MINIMUM BREAKING LOAD kN	APPROXIMATE MASS PER KM kg
Almond	6/1/2.50	7.50	29.0	34.36	10.5	119
Apple	6/1/3.00	9.00	41.8	49.48	14.9	171
Banana	6/1/3.75	11.3	65.2	77.31	22.8	268
Cherry	6/4.75 + 7/1.60	14.3	105	120.4	33.2	404
Grape	30/7/2.50	17.5	144	181.6	63.7	675
Lemon	30/7/3.00	21.0	207	261.5	90.1	973
Lime	30/7/3.50	24.5	282	356.0	121	1320
Mango	54/7/3.00	27.0	373	431.2	118	1440
Orange	54/7/3.25	29.3	438	506.0	137	1690
Olive	54/7/3.50	31.5	508	586.9	159	1960
Paw Paw	54/3.75 + 19/2.25	33.8	583	671.7	179	2250
Peach	54/4.75 + 19/2.85	42.8	936	1078	284	3600
EXTRA HIGH STRENGTH						
Quince	3/4/1.75	5.25	8.77	16.84	12.7	95.9
Raisin	3/4/2.50	7.50	17.9	34.36	24.4	193
Sultana	4/3/3.00	9.00	31.6	49.48	28.3	242
Walnut	4/3/3.75	11.3	49.4	77.31	43.9	379

ACSR/AZ – ALUMINIUM CONDUCTOR (ALUMINISED) STEEL REINFORCED.

Aust. Standard – AS1220 PART 2

CODE NAME	STRANDS/ WIRE DIAMETER mm	OVERALL DIAMETER (APPROX) mm	CALCULATED EQUIVALENT ALUMINIUM AREA mm ²	SECTIONAL AREA mm ²	CALCULATED MINIMUM BREAKING LOAD kN	APPROXIMATE MASS PER KM kg
Barley	6/1/2.50	7.50	29.0	34.36	10.3	119
Bean	6/1/3.00	9.00	41.8	49.48	14.5	171
Cabbage	6/1/3/75	11.3	65.2	77.31	21.5	268
Carrot	6/4.75 + 7/1.60	14.3	105	120.4	31.9	404
Corn	30/7/2.50	17.5	144	181.6	61.6	675
Garlic	30/7/3.00	21.0	207	261.5	87.2	973
Millet	30/7/3.50	24.5	282	356.0	116	1320
Oats	54/7/3.00	27.0	373	431.2	115	1140
Onion	54/7/3.25	29.3	438	506.0	132	1690
Parsnip	54/7/3.50	31.5	508	586.9	153	1960
Potato	54/3.75 + 19/2.25	33.8	583	671.7	177	2250
Rice	54/4.75 + 19/2.85	42.8	936	1078	277	3600

USEFUL REFERENCE TABLES

A.C.S.R. CONDUCTOR SIZES

METRIC			IMPERIAL			
CODE NAME	STRANDING	CONDUCTOR O.D.		CODE NAME	STRANDING	O.D.
		mm	inches			inches
Almond	6/2.50 + 1/2.50	7.50	.295	Gopher	6/1/093	.279
Apple	6/3.00 + 1/3.00	9.00	.354	Ferret	6/1/118	.354
Banana	6/3.75 + 1/3.75	11.3	.445	Mink	6/1/144	.432
Cherry	6/4.75 + 7/1.60	14.3	.563	Dog	6/186 + 7/062	.558
Grape	30/2.50 + 7/2.50	17.5	.689	Wolf	30/7/102	.714
Lemon	30/3.00 + 7/3.00	21.0	.827	Panther	30/7/118	.826
Lime	30/3.50 + 7/3.50	24.5	.965	Bear	30/7/132	.924
Mango	54/3.00 + 7/3.00	27.0	1.063	Bison	54/7/118	1.062
Orange	54/3.25 + 7/3.25	29.3	1.154	Brolga	54/7/129	1.162
Olive	54/3.50 + 7/3.50	31.5	1.240	Moose	54/7/139	1.251
Paw Paw	54/3.75 + 19/2.25	33.8	1.331	Finch	54/143 + 19/086	1.293

STRANDED HARD DRAWN COPPER CONDUCTOR SIZES

METRIC			IMPERIAL		
CODE NAME	CONDUCTOR O.D.		CODE NAME	CONDUCTOR O.D.	
	mm	inches		mm	inches
7/1.00	3.00	.118	7/036	2.7	.108
7/1.25	3.75	.148	7/048	3.7	.144
7/1.75	5.25	.207	7/064	4.9	.192
7/2.0	6.00	.236	7/080	6.1	.240
7/2.75	8.25	.325	19/064	8.1	.320
19/1.75	8.75	.345	7/118	9.0	.354
19/2.0	10.0	.394	7/136	10.3	.408
7/3.50	10.5	.413	19/083	10.5	.415
37/1.75	12.25	.484	37/072	12.8	.504
19/2.75	13.75	.541	-	-	-
19/3.00	15.0	.591	19/116	14.7	.580
37/2.50	17.5	.689	37/093	16.5	.651
37/2.75	19.25	.758	37/103	18.3	.721
37/3.00	21.0	.827	37/118	21.0	.826
61/2.75	24.75	.974	91/093	26.0	1.023

USEFUL REFERENCE TABLES

CABLE CROSS SECTIONS

ANNEALED ALUMINIUM AND COPPER STRANDED CONDUCTORS

METRIC			IMPERIAL				
NOMINAL CROSS SECTIONAL AREA mm ²	NUMBER AND NOMINAL DIA. OF WIRES mm	NOMINAL DIA. OF CONDUCTOR mm	NOMINAL CROSS SECTIONAL AREA mm ²	NUMBER AND NOMINAL DIA. OF WIRES inches	NOMINAL DIA. OF WIRES mm	NOMINAL CROSS SECTIONAL AREA inches ²	NOMINAL DIA. OF CONDUCTOR mm
1	1/1.13	1.13	.97	1/.044	1/1.12	.0015	1.12
–	–	–	1.25	3/.029	3/.737	.0019	1.59
1.5	1/1.38	1.38	–	–	–	–	–
–	–	–	1.93	3/.036	3/.914	.003	1.97
2.5	7/0.67	2.01	–	–	–	–	–
–	–	–	2.93	7/.029	7/.737	.0045	2.21
4	7/0.85	2.55	–	–	–	–	–
–	–	–	4.52	7/.036	7/.914	.007	2.74
6	7/1.04	3.12	–	–	–	–	–
–	–	–	6.75	7/.044	7/1.12	.010	3.35
–	–	–	9.43	7/.052	7/1.32	.0146	3.96
10	7/1.35	4.05	–	–	–	–	–
–	–	–	14.28	7/.064	7/1.63	.0025	4.88
16	7/1.70	5.10	–	–	–	–	–
–	–	–	18.29	19/.044	19/1.12	.03	5.59
25	7/2.14	6.75	25.5	19/.052	19/1.32	.04	6.60
35	19/1.53	7.65	–	–	–	–	–
–	–	–	38.7	19/.064	19/1.63	.06	8.13
50	19/1.78	8.90	–	–	–	–	–
–	–	–	65.1	19/.083	19/2.11	.10	10.5
70	19/2.14	10.70	–	–	–	–	–
–	–	–	75.3	37/.064	37/1.63	.12	11.4
95	19/2.52	12.60	95.3	37/.072	37/1.83	.15	12.8
120	37/2.03	14.21	126.7	37/.083	37/2.11	.20	14.8
150	37/2.25	15.75	–	–	–	–	–
–	–	–	159.1	37/.093	37/2.36	.25	16.5
185	37/2.52	17.64	–	–	–	–	–
–	–	–	195.1	37/.103	37/2.62	.30	18.3
240	61/2.25	20.25	–	–	–	–	–
–	–	–	262.2	61/.093	61/2.36	.40	21.3
300	61/2.52	22.68	–	–	–	–	–
–	–	–	321.6	61/.103	61/2.62	.50	23.5
–	–	–	391.1	91/.093	91/2.36	.60	26.0
400	61/2.85	25.65	–	–	–	–	–
–	–	–	479.7	91/.103	91/2.62	.75	28.8
500	61/3.20	28.80	–	–	–	–	–
630	127/2.52	32.76	–	–	–	–	–
–	–	–	669.4	127/.103	127/2.62	1.00	34.0
800	127/2.85	37.05	800.00	127/.112	127/2.84	1.24	36.92
1000	127/3.20	41.60	1000.0	127/.125	127/3.18	1.50	41.34

USEFUL REFERENCE TABLES

OVERHEAD CONDUCTORS

AAC				AAAC (1120)				AAAC (6201A)				ACSR			
STRAND CODE	AL	O.D. mm	AREA mm ²	STRAND CODE	AL	O.D. mm	AREA mm ²	STRAND CODE	AL	O.D. mm	AREA mm ²	STRAND CODE	AL	O.D. mm	AREA mm ²
Gemini	7/1.75	5.25	16.8	Argon	7/1.75	5.25	16.8	Agate	7/1.75	5.25	16.8	Quince*	3/4/1.75	5.25	16.8
Jupiter	7/2.25	6.75	27.8	Boron	7/2.25	6.75	27.8	Amethyst	7/2.25	6.75	27.8				
Leo	7/2.50	7.50	34.4	Chlorine	7/2.50	7.50	34.4	Diamond	7/2.50	7.50	34.4	Almond	6/1/2.50	7.50	34.4
												Raisin*	3/4/2.50	7.50	34.4
Leonids	7/2.75	8.25	41.6	Chromium	7/2.75	8.25	41.6	Dolomite	7/2.75	8.25	41.6				
Libra	7/3.00	9.00	49.5	Fluorine	7/3.00	9.00	49.5	Emerald	7/3.00	9.00	49.5	Apple	6/1/3.00	9.00	49.5
												Sultana*	4/3/3.00	9.00	49.5
Mars	7/3.75	11.25	77.3	Helium	7/3.75	11.25	77.3	Garnet	7/3.75	11.25	77.3	Banana	6/1/3.75	11.25	77.3
												Walnut*	4/3/3.75	11.25	77.3
Mercury	7/4.50	13.50	111.3	Hydrogen	7/4.50	13.50	111.3	Jade	7/4.50	13.50	111.3				
Moon	7/4.75	14.25	124.0	Iodine	7/4.75	14.25	124.0	Jasper	7/4.75	14.25	124.0				
												Cherry	6/4.75 7/1.60	14.30	120.4
Neptune	19/3.25	16.25	157.6	Krypton	19/3.25	16.25	157.6	Opal	19/3.25	16.25	157.6				
Orion	19/3.50	17.50	182.8	Lutetium	19/3.50	17.50	182.50	Patronite	19/3.50	17.50	182.50	Grape	30/7/2.50	17.50	181.6
Pluto	19/3.75	18.75	209.8	Neon	19/3.75	18.75	209.8	Pearl	19/3.75	18.75	209.8				
Saturn	37/3.00	21.00	261.5	Nitrogen	37/3.00	21.00	261.5	Ruby	37/3.00	21.00	261.5	Lemon	30/7/3.00	21.00	261.5
Sirius	37/3.25	22.75	306.9	Nobelium	37/3.25	22.75	306.9	Ruthenium	37/3.25	22.75	306.9				
Taurus	19/4.75	23.75	336.7	Oxygen	19/4.75	23.75	336.7	Rutile	19/4.75	23.75	336.7				
												Lime	30/7/3.50	24.50	356.0
Triton	37/3.75	26.25	408.6	Phosphorus	37/3.75	26.25	408.6	Sapphire	37/3.75	26.25	408.6				
												Mango	54/7/3.00	27.00	431.2
Uranus	61/3.25	29.25	506.4	Selenium	61/3.25	29.25	506.4	Spinel	61/3.25	29.5	506.4	Orange	54/7/3.25	29.25	506.4
Ursula	61/3.50	31.50	586.9	Silicon	61/3.50	31.50	586.9	Tantalum	61/3.50	31.50	586.9	Olive	54/7/3.50	31.50	586.9
Venus	61/3.75	33.75	673.7	Sulphur	61/3.75	33.75	673.7	Topaz	61/3.75	33.75	673.7	Paw Paw	54/3.75 19/2.25	33.75	672.0
												Peach	54/4.75 19/2.85	42.75	1078.0
Virgo	91/4.50	49.50	1447.0	Xenon	91/4.50	49.50	1447.0	Zircon	91/4.50	49.50	1447.0				

USEFUL REFERENCE TABLES

TOOL AND DIE SELECTION

STANDARD COPPER LUGS, LINKS, STALKS ETC.						
CONDUCTOR SIZE mm ²	DIE A/F mm	HAND CRIMPERS	HYDRAULIC TOOLS – HEXAGONAL DIES			
			5 TONNE #111	12 TONNE #38A #98 #41AH #98H		22 TONNE #66H
1.5	–					
2.5	–					
4	–					
6	4.4	#00 #102U		38-44CU		
10	5.7	#18/1	111-5763CU	38-57CU		
16	6.3	#16/1	111-5763CU	38-63CU		
25	7.7	#21/1	111-7792CU	38-77CU		
35	9.2	#22/1	111-7792CU	38-92CU		
50	10.4	#20/1	111-104115CU	38-104CU		
70	11.5		111-104115CU	38-115CU		
95	14.2		111-142165CU	38-142CU		
120	16.5		111-142165CU	38-160CU		
150	18.3			38-183CU		
185	20.0			38-200CU		
240	23.1			38-231CU		
300	26.0			38-260CU		
400	28.1				66-281CU	40-281CU
500	31.0				66-310CU	40-310CU
630	37.0					40-370CU
800	43.2					40-432CU
100	48.0					40-489CU

STANDARD ALUMINIUM AND BI-METAL				
CONDUCTOR SIZE mm ²	DIE A/F mm	HYDRAULIC TOOLS – HEXAGONAL DIES		
		12 TONNE #38A #98A #41AH #98H		60 TONNE #40B
1.5	–			
2.5	–			
4	–			
6	9.0	38-90AL		
10	9.0	38-90AL		
16	9.0	38-90AL		
25	9.0	38-90AL		
35	9.0	38-90AL		
50	13.2	38-132AL		
70	13.2	38-132AL		
95	17.3	38-173AL		
120	17.3	38-173AL		
150	22.0	38-220AL		
185	22.0	38-220AL		
240	28.4	38-284AL		
300	28.4	38-284AL		
400	39.0			40-390AL
500	39.0			40-390AL
630	43.2			40-432AL
800	43.2			40-525AL

USEFUL REFERENCE TABLES

NOMINAL CABLE DIMENSIONS

CROSS SECTION AREA mm ²	STRAND NO./WIRE DIA.	O.D. OF CONDUCT	O.D. OF P.V.C. SINGLE CORE CABLE	O.D. OF P.V.C. INS. SINGLE CORE SHEATHED	O.D. OF SINGLE CORE XLPE/PVC	TWO CORE	TWO CORE + EARTH	THREE CORE + EARTH	FOUR CORE + EARTH
1	1/1.13 7/0.40	1.13 1.20	2.8	4.1					
1.5	1/1.38 7/0.50	1.38 1.5	3.2	4.4		9.4			
2.5	7/0.67	2.01	3.7	5.1		10.8			
4	7/0.85	2.55	4.6	6.0		12.2			
6	7/1.04	3.12	5.2	6.6		13.4			
10	7/1.35	4.05	6.1	8.1			16.6	18.1	20.0
16	7/1.70	5.10	7.2	9.3			18.6	20.4	22.6
25	19/1.35	6.75	8.9		11.4		22.1	23.8	26.5
35	19/1.53	7.65	10.1		12.6		24.4	26.5	29.5
50	19/1.78	8.9	11.9		14.1		28.0	30.6	34.3
70	19/2.14	10.70	13.5		16.0		31.5	34.8	39.0
95	37/1.78	12.46	15.9		18.2			39.6	44.6
120	37/2.03	14.21	17.4		20.0			43.3	48.8
150	37/2.25	15.75	19.5		22.2			48.4	54.6
185	37/2.52	17.64			24.4			53.7	60.7
240	61/2.25	20.25			27.4			61.0	69.1
300	61/2.52	22.68			30.3			67.6	76.6
400	61/2.85	25.65			33.8				
500	61/3.20	28.80			35.7				
630	127/2.52	32.76			40.2				

NOMINAL DATA AS SPECIFIED IN AS/NZS 5000 -1 & 2



COMPRESSION TERMINATION THEORY

Utilux crimp lugs, links and stalk lugs are designed to be compatible with Utilux indent tools and hydraulic tools with hexagonal or indent dies. Through this exact matching the resultant terminations achieve a consistently precise compression – neither over stressed nor understressed – to produce the correct indent or hexagonal force.

The crimp is designed to bring all conductors and the connector itself into intimate contact. At the same time, the crimp is designed to avoid any reduction in the cross sectional area of the conductor, with an increased contact area.

BASIC COMPRESSION TERMINATION PRACTICES

1. Strip the cable insulation to the recommended length. Recommended stripping lengths of conductors should correspond to the barrel lengths shown in this catalogue.
2. With non plated copper conductors, scratch brushing may be carried out on the bare copper conductor. On aluminium conductors however, scratch brushing must be carried out. Terminating should be completed as soon as possible after stripping of the insulation.
3. To ensure a reliable termination, the correct connector for a given cable size must be selected. Moreover, the recommended indent tool or hexagon tool and die must also be used. See the various data tables in this catalogue for tooling recommendations.
4. Fit the connector over the stripped conductor and place the connector into the hand or hydraulic tool. Apply the recommended pressure. With hand tools, the crimp is not complete until the jaws meet or the ratchet releases. With hex dies in hydraulic tools, the faces of the die must meet.
5. The number of crimps per connector can vary. Some lugs have markings for crimps, if you require more information please contact Utilux.

TERMINATION RECOMMENDATIONS

The palm contact areas of Utilux lugs are designed to give more than that the surface of lugs are used upon has corresponding contact area. Excessive drilling out of palm holes must be avoided, to ensure that adequate palm contact, heavy gauge washers are recommended. In relation to stalk lugs and consistent with the above, care must be taken to adequately match the stalk diameter of the tunnel or mounting connector, to ensure maximum surface contact area. Bolting torques are listed in the following table.

Bolt Size	Material	Tightening Torque
3/8"	Aluminium	20 Newton Metres
1/2"	Aluminium	40 Newton Metres
M10	Aluminium	20 Newton Metres
M6	Steel	16 Newton Metres
M8	Steel	16 Newton Metres
M10	Steel	20 Newton Metres
M12	Steel	40 Newton Metres
M16	Steel	80 Newton Metres
M20	Steel	100 Newton Metres

FLEXIBLE CABLE CRIMPING

The crimping of connectors onto flexible conductors is problematic due to the large amount of air gaps between conductor strands. This results in a large physical size for a relatively small conductor cross section. Thus the standard size lug for a given area of flexible conductor is usually too small. If a larger size lug is used instead, the standard die for that size lug will not achieve the desired compression.

Indent crimping is not recommended, as the indent may damage the very fine strands of a flexible conductor which may in turn cause connector failure.

Adopting the Utilux "Half Hex" crimping method solves the problem.

This method employs a crimping shape in the form of one half of the standard hexagon shape. The dies used comprise a normal hexagon crimp die, along with a special flat die to give the half hexagon shape. The hexagon die is sufficiently large to close around the lug completely, giving adequate compression.

Normally the conductor's area will be known or can be located on the chart below. However if not known, it has to be established. To do this we require the amount of strands and individual strand diameter. Counting the amount of strands is not as daunting a task as it appears. The lay of the conductor will generally be a series of bundled strands, with each bundle having the same lay as a regular laid conductor, eg 7, 19, 37 strands etc. Having established the amount of strands to a bundle, count the amount of bundles and multiply. For example for a 95mm² the conductor may be 259/0.7 with a nominal diameter of 13.8mm, from this the true area is 99.7mm². The diameter is too large for a 95mm² barrel but will fit a 120mm² barrel. It can then be crimped using the half hex method.

Rule of thumb for matching conductor to lug, providing conductor diameter allows, is whatever the area of the conductor, choose the next size larger lug.

CSA mm ²	NO & DIA OF WIRES	OD OF CONDUCTOR	CALCULATED CSA mm ²
16	128/0.4		
	540/0.2	5.8	15.8
25	209/0.4		
	770/0.2	7.5	24.2
35	285/0.4		
	1083/0.2	8.6	34.0
50	380/0.4		
	1558/0.2	10.5	49.0
70	203/0.67		
	2204/0.2	11.6	69.3
95	259/0.67		
	2983/0.2	14.8	93.7
120	336/0.67		
	3810/0.2	15.9	119.7
150	427/0.67		
	4773/0.2	18.6	150.0
185	528/0.67		
	5881/0.2		184.8
240	5920/0.21	18.8	205.1
	672/0.67		
	7400/0.21	23.7	256.3
	73630/0.2		239.7
300	8911/0.2		280.0
	9102/0.21	26.6	315.3
400	11970/0.2		376.1
	12672/0.21	30.8	438.9

UTILUX CRIMP LUG PART NUMBER		FLEXIBLE CONDUCTOR SIZE (mm ²)			UTILUX HALF HEX SET PART NUMBER	UTILUX HALF HEX DIE SET CONSISTS OF	RECOMMENDED UTILUX TOOLING	
		NOMINAL	RANGE					
			MIN	MAX				
H1415A H1415 H1416 H1416A H1416B	M6 M8 M10 M11 M12	16	15	19.3	38-98HHEX17/1	Half 38-98CU plus 38-FLAT17	#38A #38ROBO #41A #42A #66H #98 #98H #98ROBO	
H1365 H1366 H1368 H1369	M6 M8 M10 M12	25	23.5	30.5	38-122HHEX17/1	Half 38-98CU plus 38-FLAT17		
H1419 H1420 H1421	M6 M8 M10	35	27.5	35	38-130HHEX17/1	Half 38-130CU plus 38-FLAT17		
H1422B H1422A H1422 H1423 H1423A	M6 M8 M10 M12 M16	50	47.5	58	38-153HHEX17/1	Half 38-153CU plus 38-FLAT17		
H1424B H1424C H1424 H1425 H1440 H1438	M6 M8 M10 M12 M16 M20	70	66.5	82	38-183HHEX14/1	Half 38-183CU plus 38-FLAT14		
H1381 H1382 H1383 H1382B	M10 M12 M16 M20	95	89.5	112.5	38-220HHEX14/1	Half 38-220CU plus 38-FLAT14		
H1384A H1384 H1385 H1386	M10 M12 M16 M20	120	113.5	141.5	38-245HHEX14/1	Half 38-245CU plus 38-FLAT14		
H1387A H1387 H1388 H1389	M10 M12 M16 M20	150	131	162.5	40-260HHEX25/1	Half 40-260CU plus 40-FLAT25		#40B #40BH
H1390 H1390D H1390A H1390B H1390C	MB M10 M12 M16 M20	185	174.5	219.5	40-310HHEX25/1	Half 40-310CU plus 40-FLAT25		
H1391 H1391A H1391B	MB M16 M20	240	226.5	283.5	40-340HHEX25/1	Half 40-340CU plus 40-FLAT25		
H1448 H1448A H1448B	MB M16 M20	300	266	330.5	40-370HHEX25/1	Half 40-370CU plus 40-FLAT25		
H1449 H1449A H1449B	MB M16 M20	400	381.5	460	40-410HHEX25/1	Half 40-410CU plus 40-FLAT25		

Notes:

1. Refer to pages 2 & 3 for copper lug descriptive part numbers
2. To calculate cross sectional area of cable, use following formula;

$$CSA = \frac{N \times d^2 \times \pi}{4}$$

3. Cable chart is for single core double insulated flexible cables 0.6/1kV V90.

METRIC DESCRIPTION

For simplicity in identifying connectors in this catalogue, we have designated certain products with metric coding.

This coding can be used to identify a product if the Utilux catalogue number is unknown.

The following coding applies:

A = Aluminium	K = Link
B = Bi-Metal	S = Sector
C = Copper	M = Palm Hole in mm
G = Lug	MB = Blank Palm
AGS = Aluminium Lug Sector	
AKS = Aluminium Link Sector	
BGS = Bi-Metal Lug Sector	
BKS = Bi-Metal Link Sector	
AG = Aluminium Lug	AK = Aluminium Link
BG = Bi-Metal Lug	BK = Bi-Metal Link
BS = Bi-Metal Stalk	CG = Copper Lug
CK = Copper Link	

The cable area in sqmm and the palm hole is included to complete the description, eg:

(a) BKS70/50 is a Bi-Metal Link Sector, 70mm² solid aluminium to 50mm² stranded copper.

(b) AGS300/M16 is an Aluminium Lug Sector Cable 300mm² solid 16mm palm hole.

(c) AKS240 is an Aluminium Link Sector Cable 240mm² solid.

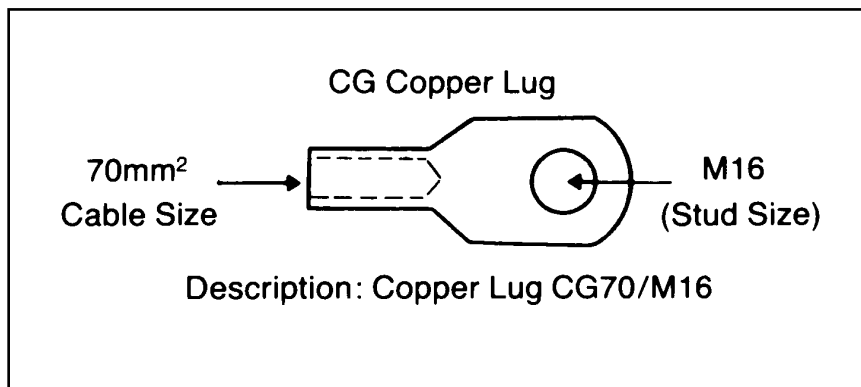

Note: This guide covers a wide, but not exhaustive, range of our products. If you have a special requirement it may be available in our extensive non standard range or, through our Utilux Express service. Please discuss with your Utilux distributor.

ERGONOMIC DESIGN –

THE KEY TO SAFE, COMFORTABLE WORK PRACTICE

Poorly designed hand tools can often cause strain injury to the hands or lower arm and, at best, can make repetitive tasks tiring and uncomfortable. The Utilux range of Ergonomic Design Hand Crimp Tools combines high quality and durable design and manufacture with the best of current ergonomics science for optimal operator safety and comfort. These tools, developed in co-operation with prominent ergonomists, offer maximum performance and user-friendliness. Some important features are;



The optimum grip diameter is the width of the handles measured at the centre of the hand. Tools should be designed so that the maximum force needed is required at the optimum grip diameter.



The shape of the handles offers a comfortable one-hand grip even at maximum opening.



The unique mechanical advantage means that very small forces are required to crimp the connector and cable to fix them in the correct position.



When the connector and cable are fixed, the final crimping can be done with a comfortable two-hand grip.

GOOD MECHANICAL FUNCTION

The lower the hand force required to operate a tool, the lower is the risk of overloading and injury. Utilux Ergonomic Design Tools are equipped with a unique mechanism which reduces the need for muscle force by 45%.

OPTIMUM GRIP DIAMETER

The position at which the hand can transfer most force with minimal stress varies from individual to individual and is also significantly different between men and women. Utilux Ergonomic Design Tools feature handle designs that provide a comfortable optimum grip zone for any operator.

TWO HAND GRIP FEATURE

Our Ergonomic Design Tools feature handles which allow two-hand operation in the final, high force, crimping phase. This dramatically increases crimping force while reducing the possibility of strain or injury.

WEIGHT AND BALANCE

Low weight and good balance are an integral comfort and safety feature of Utilux Ergonomic Design Tools. Handles are precisely shaped to distribute the loading across the palm and four fingers rather than concentrating it on only a few fingers. This distributes surface pressure over the largest possible area of the hand.

HANDLE MATERIAL

Material used for handle grips is carefully selected to exhibit the correct co-efficient of friction when in contact with the skin. This reduces slippage and increases control.

THE HAND – A PRECISION TOOL

The human hand is a powerful, precision tool in its own right. It is our most important means of contact with the environment. But, like any precision instrument, it is sensitive to abuse. The use of quality ergonomically correct tools will help protect this most important part of the human body.

SPARE PARTS LIST

#38	HAND OPERATED HYDRAULIC CRIMPING TOOL
#98	HAND OPERATED HYDRAULIC CRIMP TOOL
#41AH	HEAVY DUTY HYDRAULIC CRIMPING HEAD (C FRAME)
#98H	HEAVY DUTY HYDRAULIC CRIMPING HEAD (C FRAME)
#40BH	HYDRAULIC CRIMPING HEAD
#67H	HEAVY DUTY HYDRAULIC CRIMPING HEAD (U FRAME)
#38 ROBO	ROBO BATTERY OPERATED HYDRAULIC CRIMPING TOOL
#UC6ROBO	HEAVY DUTY BATTERY OPERATED HYDRAULIC CRIMPING TOOL
#98ROBO	HEAVY DUTY BATTERY OPERATED HYDRAULIC CRIMPING TOOL
#REC 50U	BATTERY OPERATED CABLE CUTTER
#CCSP55	HYDRAULIC CABLE CUTTER HEAD
#CCSP100	HYDRAULIC CABLE CUTTER HEAD
#CCS20A	HAND OPERATED HYDRAULIC CABLE CUTTER
#CCS40A	HAND OPERATED HYDRAULIC CABLE CUTTER
#108	RATCHET CABLE CUTTER



UTILUX | SPARE PARTS LIST

Product - #38A

Description - Hand Operated Hydraulic Crimping Tool

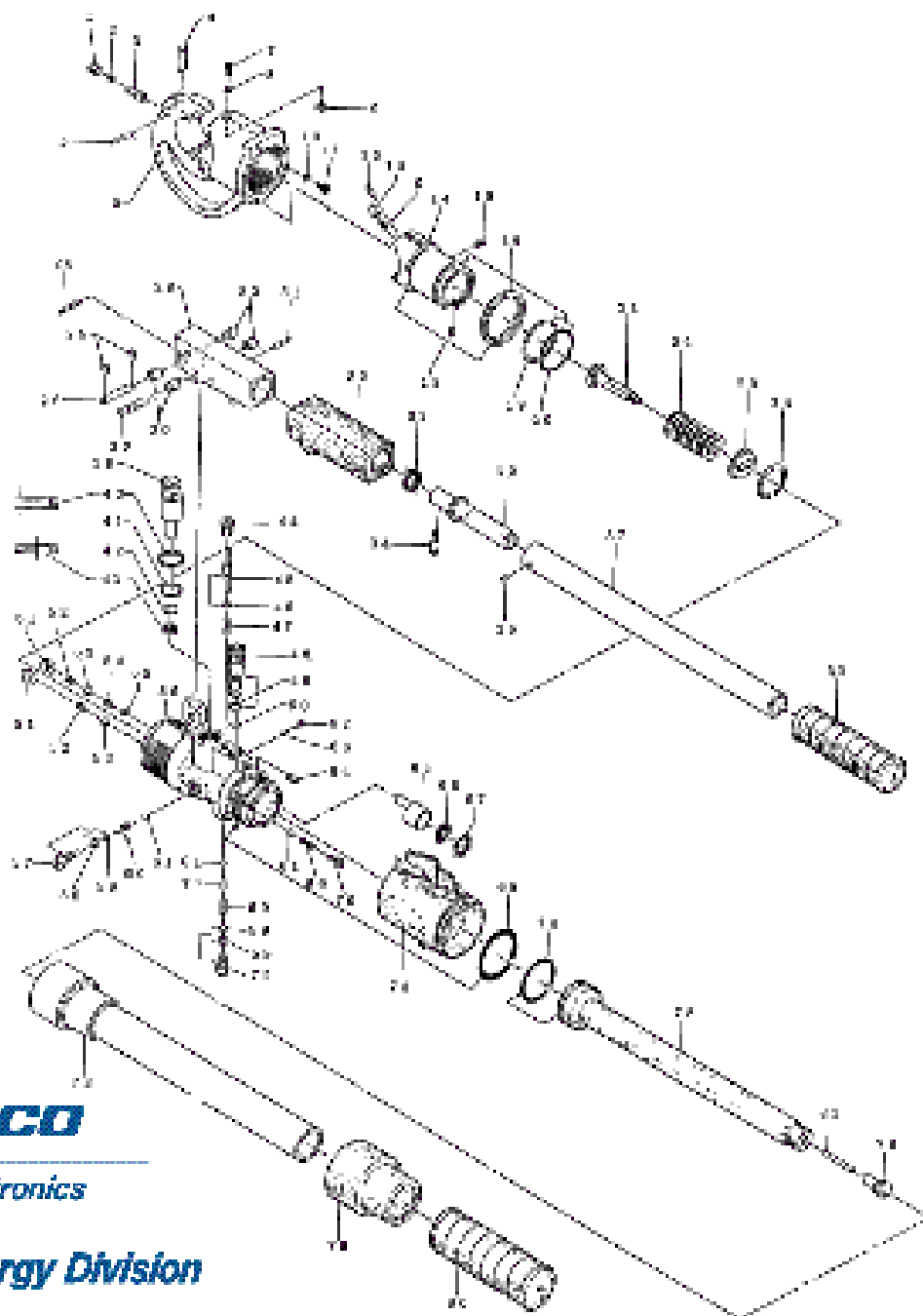

NO.	DESCRIPTION	CODE	QTY	NO.	DESCRIPTION	CODE	QTY
1	M10X10 Screw (J.T.)	10-11	1	50	O-Ring (OUP)	A1-0-40	1
2	Spring (177)	970-01	2	51	Hydro Control (HO)	A1-0-41	2
3	Roller Pin (2)	270-02	1	52	Hydro (PT)	05-001	2
4	Roller Pin (2)	270-02	1	53	Roller Pin	14-11	2
5	2-1/2" O.D. Drive Pin (DVA)	970-03	1	54	Hydro (PH)	05-011	1
6	Head	970-05	1	55	2902' Dial	15-19	1
7	M4 X 1/2 Screw	970-06	1	56	Code	A1-0-42	1
8	M4 Lock Washer	970-07	1	57	Suction Valve Plug	A1-0-43	1
9	Key	270-08	1	58	4-1/2" Push Up (P.U.)	270-09	2
10	M4 Lock Washer	970-08	2	59	4-1/2" Ring (RPM)	270-05A	2
11	M4 X 1/2 Screw	970-08	2	60	Hydro (H)	14-11	1
12	2-1/2" O.D. Drive Pin (DVA)	970-11	1	61	2902' Dial	15-25	1
13	Roller Pin (2)	970-12	1	62	M4 X 1/2 Screw (J.T.)	05-17	1
14	Roller	970-13	1	63	1/8" Dial	A1-0-20	1
15	Drive Pin (2)	970-14	1	64	M2 X 1/2 Screw	A1-0-48	1
16	Head Pin	270-15	1	65	Roller Pin	270-20A	1
17	2-1/2" O.D. Drive Pin (DVA)	970-17	1	66	Roller Pin	270-20	1
18	4-1/2" Push Up (P.U.)	270-18	1	67	Roller Pin	270-21	1
19	O-Ring (C.T.)	970-20	1	68	2-1/2" O-Ring	7900A-C5	1
20	Roller Spring Guide	970-21	1	69	Spring (H)	05-19	2
21	Roller Spring (R)	970-22	1	70	Hydro Control (C)	A1-0-38	1
22	Roller Spring (R)	970-23	1	71	Hydro (H)	270-30	1
23	Roller Spring Plug (P)	970-24	1	72	Roller Plug (P)	270-32	1
24	2902' Ring (R)	970-25	1	73	Hydro (H)	270-33	1
25	Pin (R)	970-26	1	74	2-1/2" O-Ring	79-25	1
26	Pin (R)	970-27	1	75	Oil Release Valve	A1-0-54	1
27	2-1/2" O.D. Drive Pin (DVA)	25-27A	1	76	Telescope Cap	A1-0-55	1
28	Roller Pin (R)	270-28	1	77	Hydro (H) (R)	270-35A	1
29	Roller Pin	270-29	4	78	Hydro (H) (R)	270-36	1
30	2-1/2" O.D. Drive Pin (DVA)	970-29	1	79	Hydro (H) (R)	270-37	1
31	Handle Head (Insulation)	970-31	1	80	Magnet	700-02	1
32	Spring (H)	25-32	1				
33	Push Pin	25-33	1				
34	Pump Head & Stem	970-34	1				
35	2-1/2" O.D. Drive Pin (DVA)	970-35	1				
36	Roller Pin (R)	970-36	1				
37	Roller Pin (R)	970-37	1				
38	Pump Head (H)	970-38	1				
39	Pump Pin	970-39	1				
40	O-Ring (R)	970-40	1				
41	O-Ring (C.T.)	970-38A	1				
42	4-1/2" Push Up (P.U.) (C.T.)	270-42	1				
43	4-1/2" Ring (R)	79-43	1				
44	Roller Pin (R) (R)	270-44	1				
45	Roller Pin (R) (R)	970-45	1				
46	O-Ring (OUP)	10-27	1				
47	Spring (H)	25-37	1				
48	Pump Head (R)	970-39	1				
49	O-Ring (R)	970-41	1				

tyco

Electronics

Energy Division



UTILUX | SPARE PARTS LIST

Product - #40BH

Description - Hydraulic Crimping Head

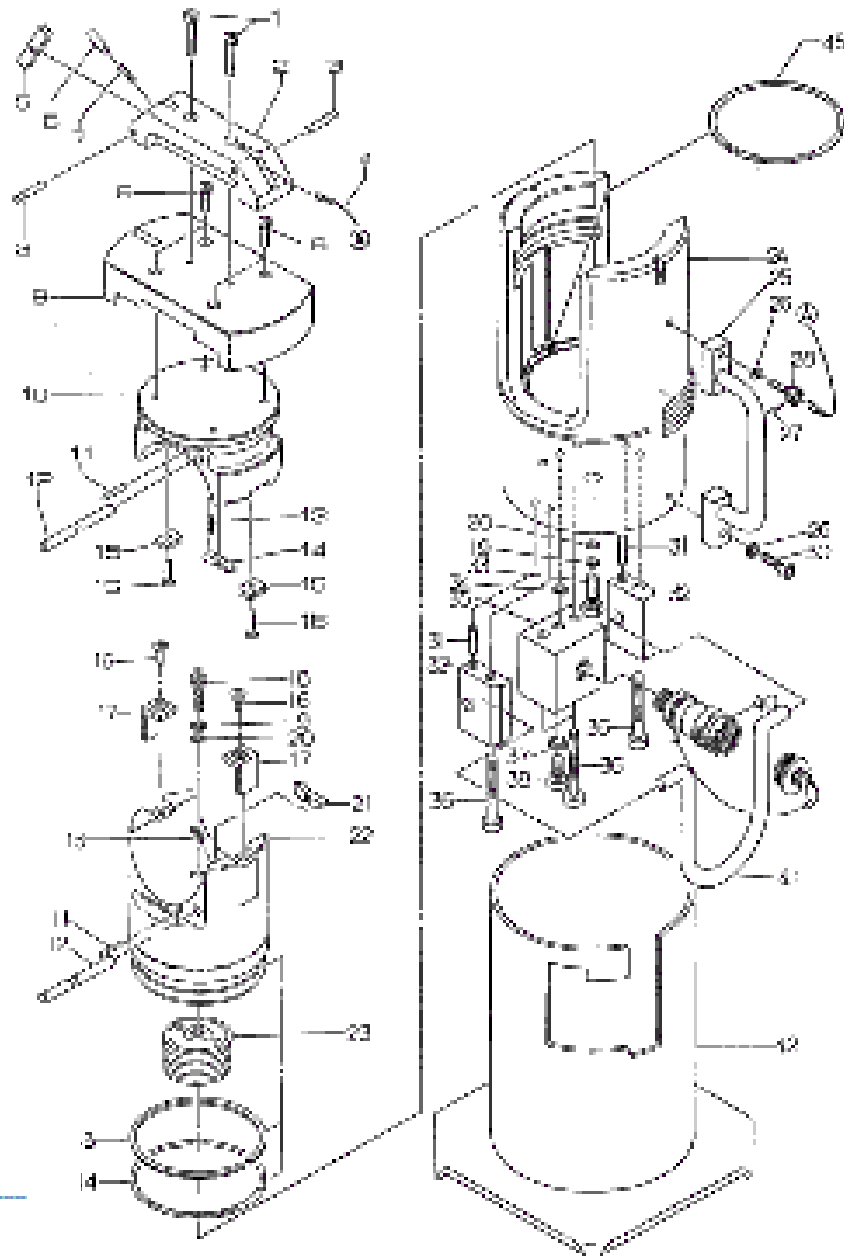

PN#	DESCRIPTION	QUANTITY	
1	SB X 24 Screw	40-04	2
2	Hex Nut	40-05	1
3	5/16 X 24 Round Pin (2)	50-01	2
4	Washer	50-02	1
5	Toggle	40L-02	1
6	Pin	40L-03	1
7	Spring (2)	40-06	1
8	SB X 24 Screw	40L-01	4
9	Cap	40L-08	1
10	Holder Retainer	40L-07	1
11	3/8 X 24 Dome Tip (2)	40L-09	2
12	Pin (2)	40L-04	2
13	Spring (2)	40L-10	2
14	Top Die Retainer	40L-11	1
15	Washer	40L-12	2
16	SB X 20 Screw	40L-13	4
17	Flare Guide	40L-14	2
18	Spring Anchor Screw (2)	50-07	1
19	40 L Flare Locking Ring (2)	40L-15	2
20	40 L Ring	40L-16	2
21	Flare Die Retainer	40L-17	1
22	Flare	50-08	1
23	Flare Spring Assy	50-09	1
24	Cylinder	50-10A	1
25	Washer	40L-18	1
26	SB X 24 Screw	40L-19	2
27	3/8 X 24 Round Pin (2)	40L-20	1
28	Circle Retainer	50-10	1
29	SB X 20 Screw	40L-19	1
31	Parallel Pin 5/16 X 1/2 (2)	50-11	2
32	Spring Retainer Assy	40L-21	2
33	Spring Retainer Pin (2)	40L-22	1
34	40 L Ring	40L-23	1
35	40 L Flare Lock	40L-24	1
36	SB X 20 Screw	40L-25	4
37	Copper Gasket (2)	50-20	1
38	SB X 20 Screw	40L-26	1
40	Flare Die Guide (PM Type)	40L-27	1
41	O Ring	40L-28	1
42	O Ring	40L-29	1
43	P-90 Die-Lite Ring (2)	50-21	1
44	P-90 O-Ring	50-22	1
45	O Ring (2)	50-23	1

tyco

Electronics

Energy Division



UTILUX | SPARE PARTS LIST

Product - #38 ROBO

Description - Battery Operated Hydraulic Crimping Tool

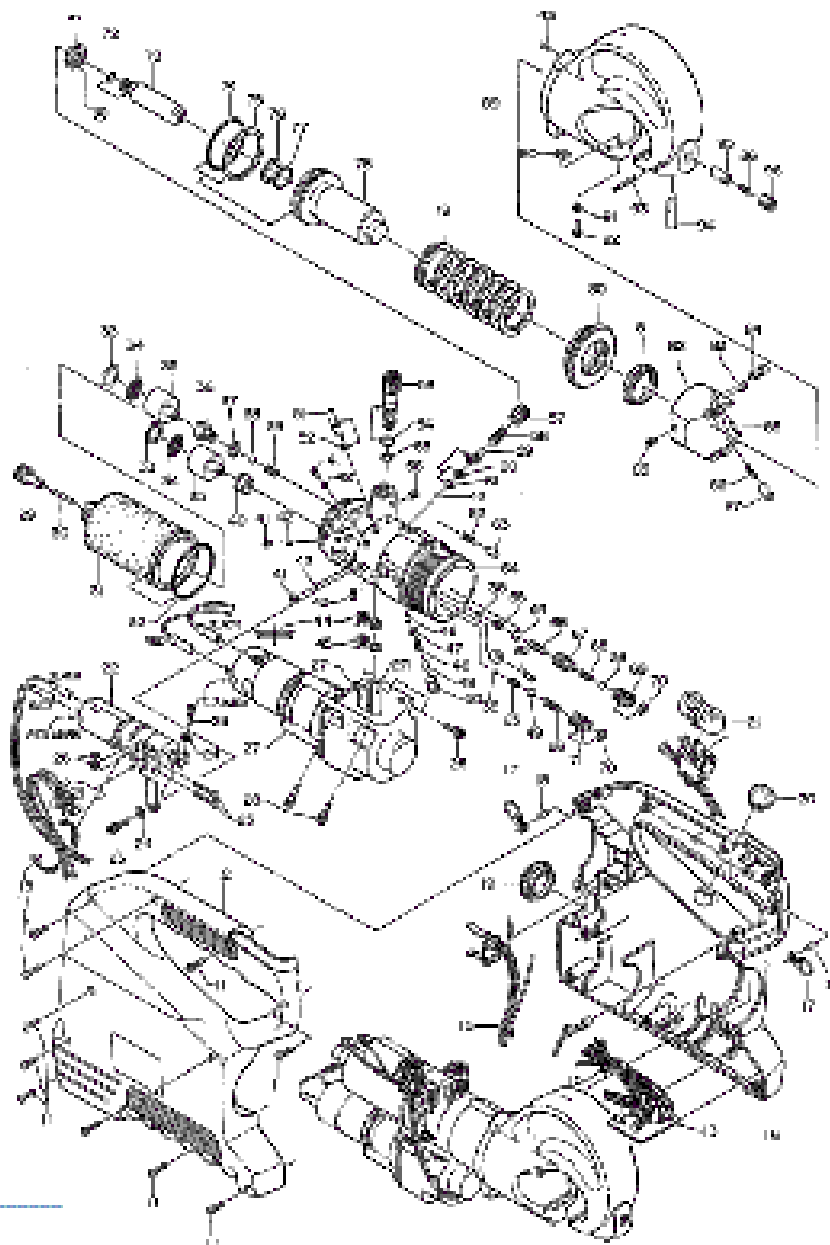

NO.	DESCRIPTION	CODE	QTY	NO.	DESCRIPTION	CODE	QTY
11	M10X15 Screw	1010-0	18	21	P-2 Back-Up Ring (3/4")	02-126	1
12	Washer (3)	02-49	-	21	P-2 O-Ring	09-28	1
13	Control Nut	007-100	-	22	Spring (27)	01-77	1
14	Pin (2)	004-02	4	23	Spring Pin	001-00	1
15	Hex Nut (2)	007-100	-	24	Pin	001-77	1
17	Hanging Ring Assy	1000-120A	2	25	Spring (2)	02-46	2
18	4 X 1/2 Parallel Pin	02-49	2	26	Spring (27)	02-28	2
19	C1 Feed Cap	02-400	-	27	Valve Screw (2)	02-140	1
20	2 1/2 In Lip Ring	0024-120	-	28	Spring (24)	01-77	1
21	Control Knob	007-100	-	29	Valve Assembly	001-70	1
22	Hex Nut (2)	007-100	-	30	Pin (2)	10-00	2
23	M10X10 Screw	02-400	2	31	Valve Screw (2)	0204-00	1
24	M10 Flat Washer	10-01	2	32	O-Ring	02-120	1
25	M10X1.5 Screw	1000-00	2	33	Inner Ring	01-01A	1
26	M10X1.5 Nut	1000-02	2	34	P-41 O-Ring	1100-20	1
27	Pin (1)	007-100	-	35	P-41 Back-Up Ring (3/16")	10-00	1
28	M10X1.5 Screw (PC)	0024-120-A	4	36	P-41 Back-Up Ring (3/16")	20-24	1
29	Hex Nut (2)	01-000	-	37	P-41 O-Ring	20-20	1
30	Magnet	0000-02	-	38	Pin	01-000	1
31	C1 Teevalve (27)	02-112	-	39	Pin Spring (20)	01-00	1
32	P-43 O-Ring	1000-02	-	40	O-Ring	01-00	1
33	2 1/2 In Ring	01-010	2	41	Back-Up Ring	000-00	1
34	Pin (2)	01-010	2	42	Back-Up Ring	001-000	1
35	Pin (2)	01-020	2	43	M10X1.5 Screw (2 - 1)	1000-10	2
36	Strainer Casting (1)	02-11	-	44	Die Tolerance Pin	01001	1
37	Cooper-Gilbert (2)	1000A-17	-	45	2 1/2 X 1/4 Die Pin (2A)	01001	1
38	2 1/2" Ball	10-40	4	46	Spring (77)	01001	2
39	Spring (24)	01-77	-	47	Back-Up Ring	01007	1
40	Hex Nut (2)	0024-02	-	48	Nut	001-07	1
41	M10X1.5 Screw (2)	01-00-00	0	49	Pin	01000	1
42	2707 Ball	0201	4	50	Pin Lock Washer	01007	1
43	2 X 1/2 Die Pin (2)	0100-01	2	51	M10X1.5 Screw	01000	1
44	P-40 Flat Gasket	10-40	2	52	2 1/2 X 1/4 Die Pin (2A)	01000	1
45	P-40 Back-Up Ring (3/16")	0201	2	53	Die Tolerance Pin (2)	01000	1
46	2707 Ball	0020	-	54	Back-Up Ring	01007	1
47	M10X1.5 Screw	0020	-	55	M10X1.5 Screw (2 - 1)	10-01	1
48	Spring (7)	0020	-	56	Spring Pin	001-00	1
49	2707 Ball	10-40	2	57	M10X1.5 Screw	00100	1
50	M10X1.5 Screw (2)	10-01	-	57A	Pin (2)	1000-00	2
51	Control Pin	02-112	-				
52	M10X1.5 Ring	0020	-				
53	Control Casting	0011-00	-				
54	M10X1.5 Ring	01-017	-				
55	P-40 O-Ring (2)	1000-02	-				
56	M10X1.5 Screw	000-70	-				
57	Valve Screw (2)	02-112	-				
58	Spring (24)	007-70	-				
59	Reduction Valve	02-112	-				

tyco
Electronics

Energy Division



UTILUX | SPARE PARTS LIST

Product - #108

Description - Ratchet Cable Cutter

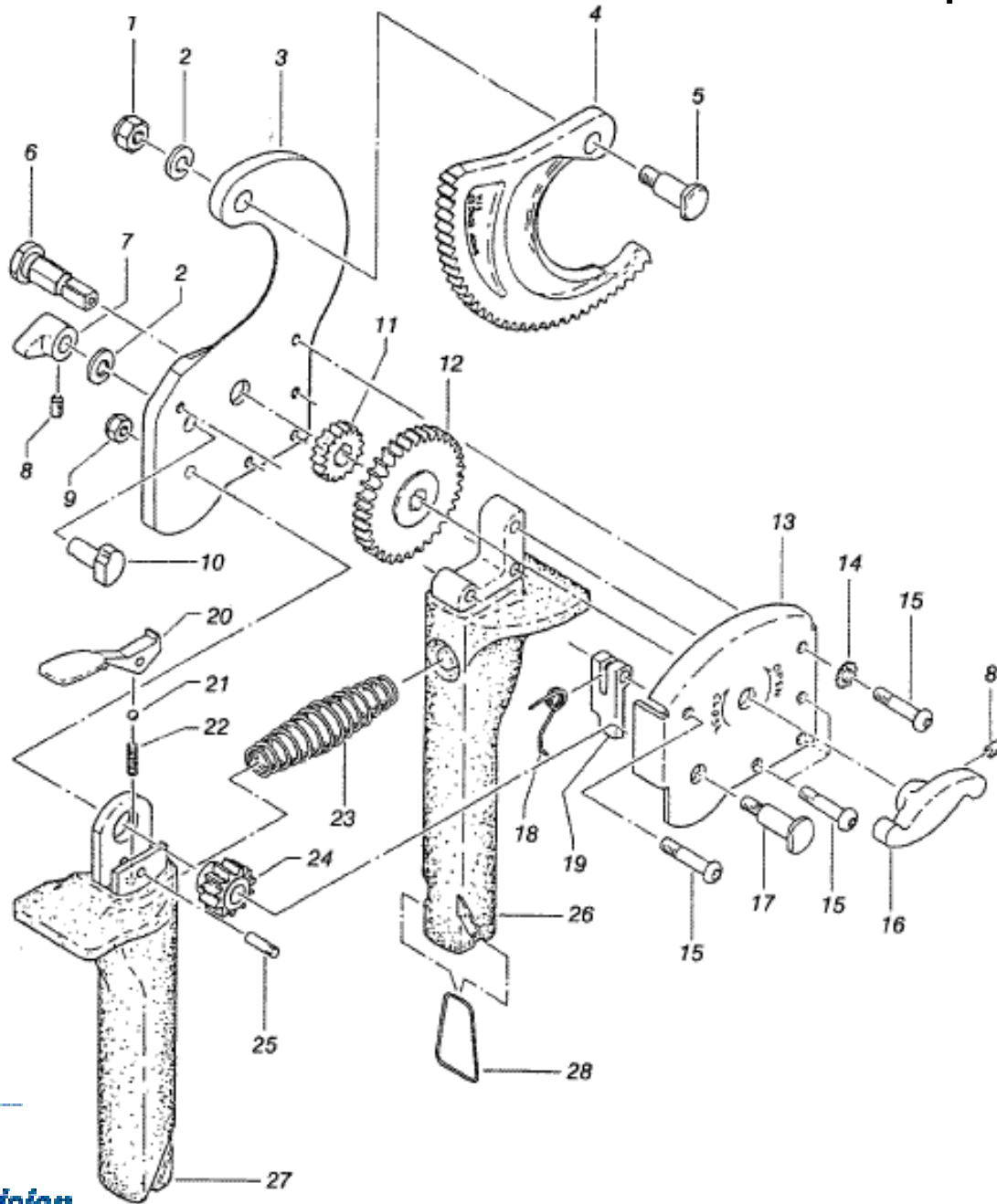

NO.	DESCRIPTION	CODE	QTY
1	Hex. nut	RCC-01	1
2	Lock washer	16-02	2
3	Stationary blade	RCC-03	1
4	Moving Blade	RCC-03	1
5	Pivot Pin	RCC-04	1
6	Gear Shaft	RCC-05	1
7	Stop knob	RCC-06	1
8	Screw	RCC-07	2
9	Hex. nut	RCC-08	1
10	Pawl	RCC-09	1
11	Small gear	RCC-10	1
12	Large gear	RCC-11	1
13	Housing	RCC-12	1
14	Star washer	RCC-13	1
15	Bolt	RCC-14	3
16	Hand crank	RCC-15	1
17	Gear pin	RCC-16	1
18	Spring	RCC-17	1
19	Pawl stopper	RCC-18	1
20	Ratchet lever	RCC-19	1
21	Ball	RCC-20	1
22	Spring	RCC-21	1
23	Handle spring	RCC-22	1
24	Medium gear	RCC-23	1
25	Dowel pin	RCC-24	1
26	Stationary handle	RCC-25	1
27	Moving handle	RCC-26	1
28	Handle retainer	RCC-27	1
29	M10 x 10 Hex screw	RCC-28	1

tyco

Electronics

Energy Division



UTILUX | SPARE PARTS LIST

Product - #98

Description - Hand Operated Hydraulic Crimp Tool

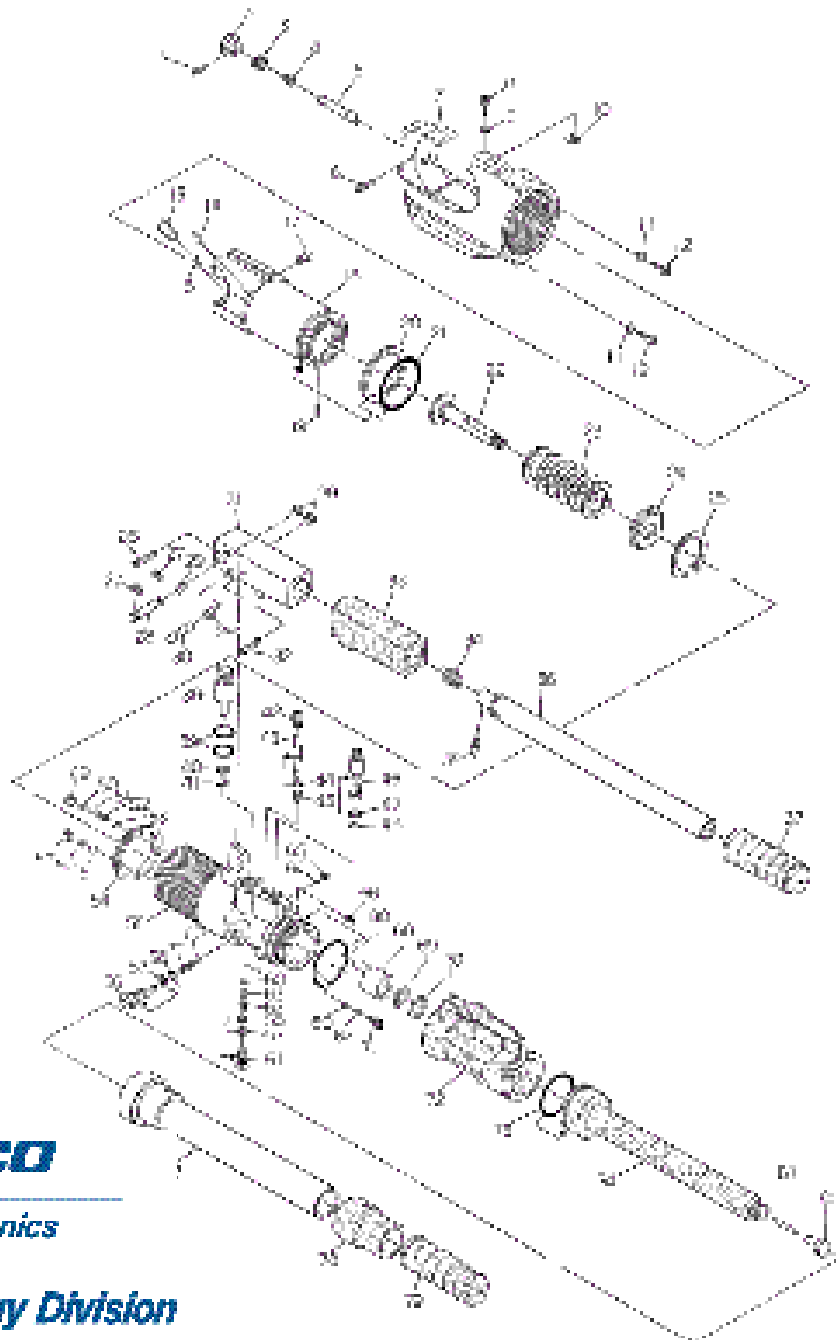

NO.	DESCRIPTION	QUANTITY	UNIT	NO.	DESCRIPTION	CODE	QTY
1	2 x O-Ring (100)	40-21	1	21	Spring (H)	20-21	2
2	Head	910-01	1	22	Spring (H)	20-22	2
3	Screw (M)	210-02	1	23	Spring (H)	20-23	1
4	Spring (M)	210-03	1	24	Spring (H)	20-24	1
5	Ball Valve Pin (M)	210-04	1	25	Spring (H)	20-25	1
6	Ball Valve Pin (M)	210-05	1	26	Spring (H)	20-26	1
7	Head	910-06	1	27	Spring (H)	20-27	1
8	Ball Valve Pin (M)	210-07	1	28	Spring (H)	20-28	1
9	Ball Valve Pin (M)	210-08	1	29	Spring (H)	20-29	1
10	Ball Valve Pin (M)	210-09	1	30	Spring (H)	20-30	1
11	Ball Valve Pin (M)	210-10	1	31	Spring (H)	20-31	1
12	Ball Valve Pin (M)	210-11	1	32	Spring (H)	20-32	1
13	Ball Valve Pin (M)	210-12	1	33	Spring (H)	20-33	1
14	Ball Valve Pin (M)	210-13	1	34	Spring (H)	20-34	1
15	Ball Valve Pin (M)	210-14	1	35	Spring (H)	20-35	1
16	Ball Valve Pin (M)	210-15	1	36	Spring (H)	20-36	1
17	Ball Valve Pin (M)	210-16	1	37	Spring (H)	20-37	1
18	Ball Valve Pin (M)	210-17	1	38	Spring (H)	20-38	1
19	Ball Valve Pin (M)	210-18	1	39	Spring (H)	20-39	1
20	Ball Valve Pin (M)	210-19	1	40	Spring (H)	20-40	1
21	Ball Valve Pin (M)	210-20	1	41	Spring (H)	20-41	1
22	Ball Valve Pin (M)	210-21	1	42	Spring (H)	20-42	1
23	Ball Valve Pin (M)	210-22	1	43	Spring (H)	20-43	1
24	Ball Valve Pin (M)	210-23	1	44	Spring (H)	20-44	1
25	Ball Valve Pin (M)	210-24	1	45	Spring (H)	20-45	1
26	Ball Valve Pin (M)	210-25	1	46	Spring (H)	20-46	1
27	Ball Valve Pin (M)	210-26	1	47	Spring (H)	20-47	1
28	Ball Valve Pin (M)	210-27	1	48	Spring (H)	20-48	1
29	Ball Valve Pin (M)	210-28	1	49	Spring (H)	20-49	1
30	Ball Valve Pin (M)	210-29	1	50	Spring (H)	20-50	1
31	Ball Valve Pin (M)	210-30	1	51	Spring (H)	20-51	1
32	Ball Valve Pin (M)	210-31	1	52	Spring (H)	20-52	1
33	Ball Valve Pin (M)	210-32	1	53	Spring (H)	20-53	1
34	Ball Valve Pin (M)	210-33	1	54	Spring (H)	20-54	1
35	Ball Valve Pin (M)	210-34	1	55	Spring (H)	20-55	1
36	Ball Valve Pin (M)	210-35	1	56	Spring (H)	20-56	1
37	Ball Valve Pin (M)	210-36	1	57	Spring (H)	20-57	1
38	Ball Valve Pin (M)	210-37	1	58	Spring (H)	20-58	1
39	Ball Valve Pin (M)	210-38	1	59	Spring (H)	20-59	1
40	Ball Valve Pin (M)	210-39	1	60	Spring (H)	20-60	1
41	Ball Valve Pin (M)	210-40	1	61	Spring (H)	20-61	1
42	Ball Valve Pin (M)	210-41	1				
43	Ball Valve Pin (M)	210-42	1				
44	Ball Valve Pin (M)	210-43	1				
45	Ball Valve Pin (M)	210-44	1				
46	Ball Valve Pin (M)	210-45	1				
47	Ball Valve Pin (M)	210-46	1				
48	Ball Valve Pin (M)	210-47	1				
49	Ball Valve Pin (M)	210-48	1				
50	Ball Valve Pin (M)	210-49	1				
51	Ball Valve Pin (M)	210-50	1				
52	Ball Valve Pin (M)	210-51	1				
53	Ball Valve Pin (M)	210-52	1				
54	Ball Valve Pin (M)	210-53	1				
55	Ball Valve Pin (M)	210-54	1				
56	Ball Valve Pin (M)	210-55	1				
57	Ball Valve Pin (M)	210-56	1				
58	Ball Valve Pin (M)	210-57	1				
59	Ball Valve Pin (M)	210-58	1				
60	Ball Valve Pin (M)	210-59	1				
61	Ball Valve Pin (M)	210-60	1				



UTILUX | SPARE PARTS LIST

Product - #41AH

Description - Heavy Duty Hydraulic Crimping Head
(C Frame)

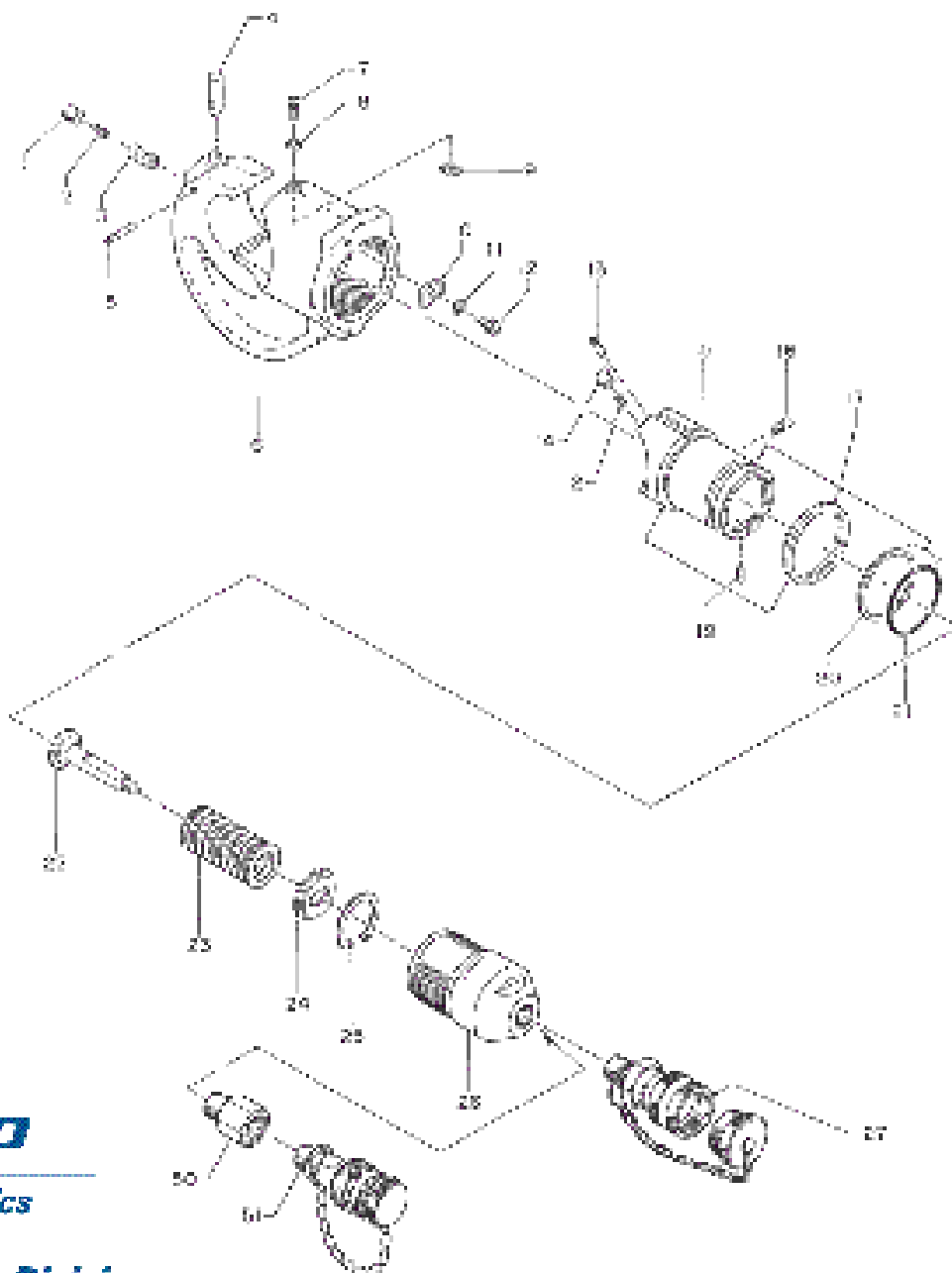

NO.	DESCRIPTION	CODE	QTY
1	Pin C-A (3 Groove) (CP)	41341	-
2	Spring (77)	41342	2
3	Die Head (Pin A)	41343	-
4	Die Head (Pin B)	41344	-
5	Pin C-A (New Pin) (DP)	41345	-
6	Head	41346	-
7	Pin X-80 Cores	41347	-
8	Pin Lock Washer	41348	-
9	Key	41349	-
10	Washer	41350	-
11	Ball Lock Washer	41351	-
12	Pin X-80 Cores	41352-02	-
13	Pin X-80 Drive Pin (DP)	41353	-
14	Washer (Pin B)	41354	-
15	Wash	41355	-
16	Die Head (Pin A)	41356	-
17	Die Head	41357	-
18	Pin X-80 New Pin (CP)	41358	-
19	Pin X-80 Gro-Up (Pin) (CP)	41359	-
20	Pin X-80 Ring (CP)	41360	-
21	Pin Spring Guide	41361	-
22	New Spring (DP)	41362	-
23	New Spring (DP)	41363	-
24	Pin X-80 (Pin)	41364	-
25	Cylinder	41365-02	-
26	Female Coupler P-11 Type	41366	-
27	Female Coupler P-11 Type	41367-02	-
28	Female Coupler P-11 Type	41368	-

tyco
Electronics

Energy Division



UTILUX | SPARE PARTS LIST

Product - #98H

Description - Heavy Duty Hydraulic Crimping Head
(C Frame)

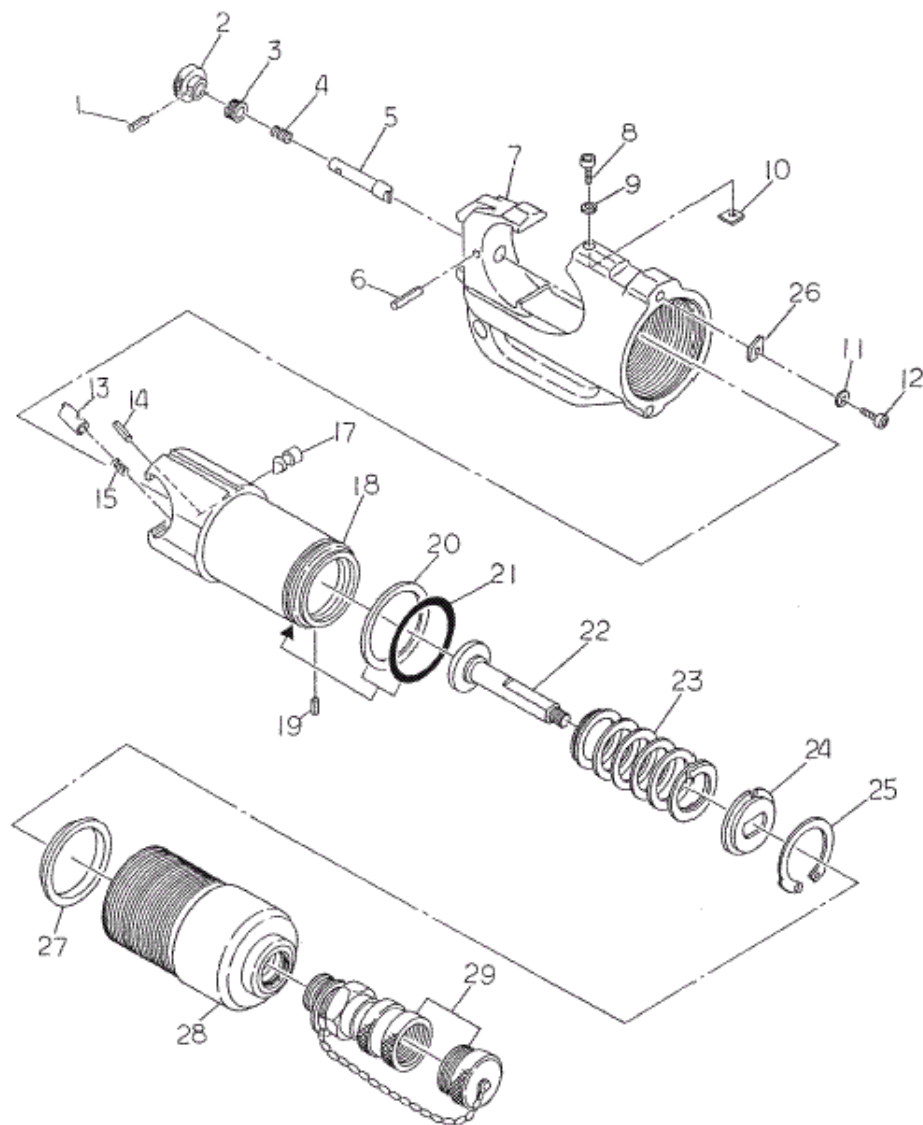

NO.	DESCRIPTION	CODE	QTY
1	2.0012 Drive Pin (DPI)	4021	1
2	Pin	512-01	1
3	Washer (W)	411102	1
4	Spring (SP)	411101	1
5	Washer (W)	411104	1
6	2.0012 Drive Pin (DPI)	412-01	1
7	Head	5124-09	1
8	Guide Screw	5124-15	1
9	Washer (W)	411102	1
10	Pin	411101	1
11	Washer (W)	411104	1
12	Washer (W)	4124-02	1
13	Washer (W)	412-12	1
14	2.0014 Drive Pin (DPI)	412-11	1
15	Spring (SP)	412-01	1
16	Washer (W)	411101	1
17	Pin	411101	1
18	Pin (Pin) (P)	411101	1
19	P-2 Dash-Up Ring (DUR)	512-13	1
20	P-2 C-Ring (CR)	117-05	1
21	Spring (SP)	5124-02	1
22	Washer (W)	411101	1
23	Washer (W)	411101	1
24	Washer (W)	411101	1
25	Washer (W)	411101	1
26	Washer (W)	411101	1
27	Washer (W)	411101	1
28	Washer (W)	411101	1
29	Washer (W)	411101	1

tyco

Electronics

Energy Division



UTILUX | SPARE PARTS LIST

Product - #67H

Description - Heavy Duty Hydraulic Crimping Head (U Frame)

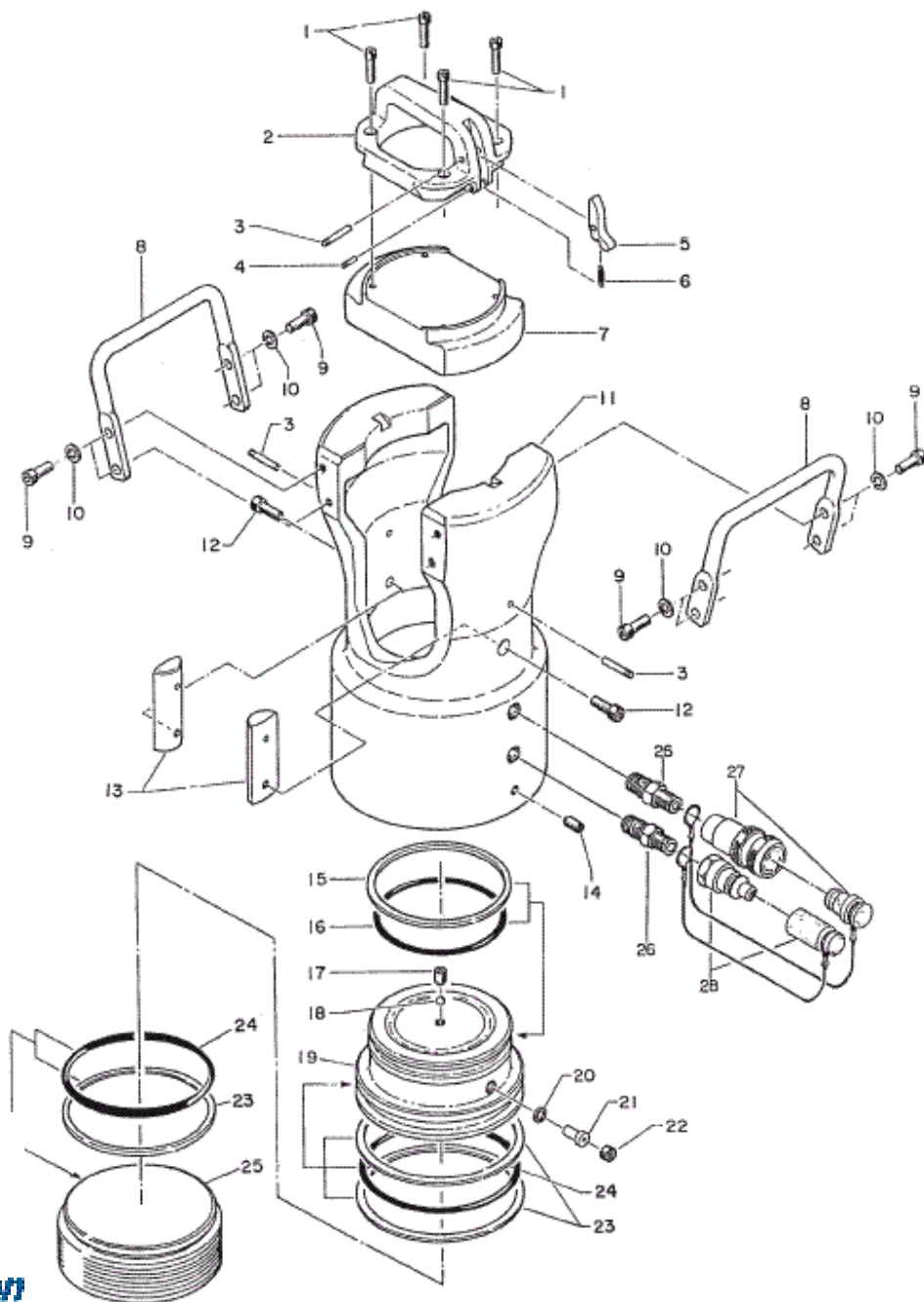

NO.	DESCRIPTION	CODE	QTY
1	ISO 2025 Screws	100MA01	4
2	Cast Handle	100MA02	1
3	Pin 2 (1/8" Standard)	200-10	4
4	Pin 2 (1/8" Heavy Duty)	100MA03	1
5	Trigger	100MA04	1
6	Spring (1.00)	20-08	1
7	Head Cap	100MA05	1
8	Grip	100MA07	2
9	ISO 2025 Screws	100MA08	4
10	ISO 2025 Washers	20-05	4
11	Washer	100MA09	1
12	ISO 2025 Screws	100MA10	2
13	Clips	100MA11	2
14	ISO 2025 Screws (DP)	100MA12	2
15	Pin (1/8" Standard)	100MA13A	1
16	Pin (1/8" Heavy)	100MA14	1
17	ISO 2025 Screws (DP)	211-02	1
18	Pin (1/8")	20-07	1
19	Flange	100MA15	1
20	Cooper Gasket (20)	100MA17	1
21	Gasket Valve (40)	100MA18	1
22	ISO 2025 Screws	100MA19	1
23	Pin (1/8" Heavy)	100MA20	1
24	Pin (1/8" Heavy)	100MA21	2
25	Cylinder Cap	100MA22	1
26	Hydraulic Hose (PTAL 507) (1/2")	60-10	2
27	Female Coupler (1)	100-28	1
28	Male Coupler (1)	100-28	1



UTILUX | SPARE PARTS LIST

Product - #UC6ROBO

Description - Heavy Duty Battery Operated Hydraulic Crimping Tool

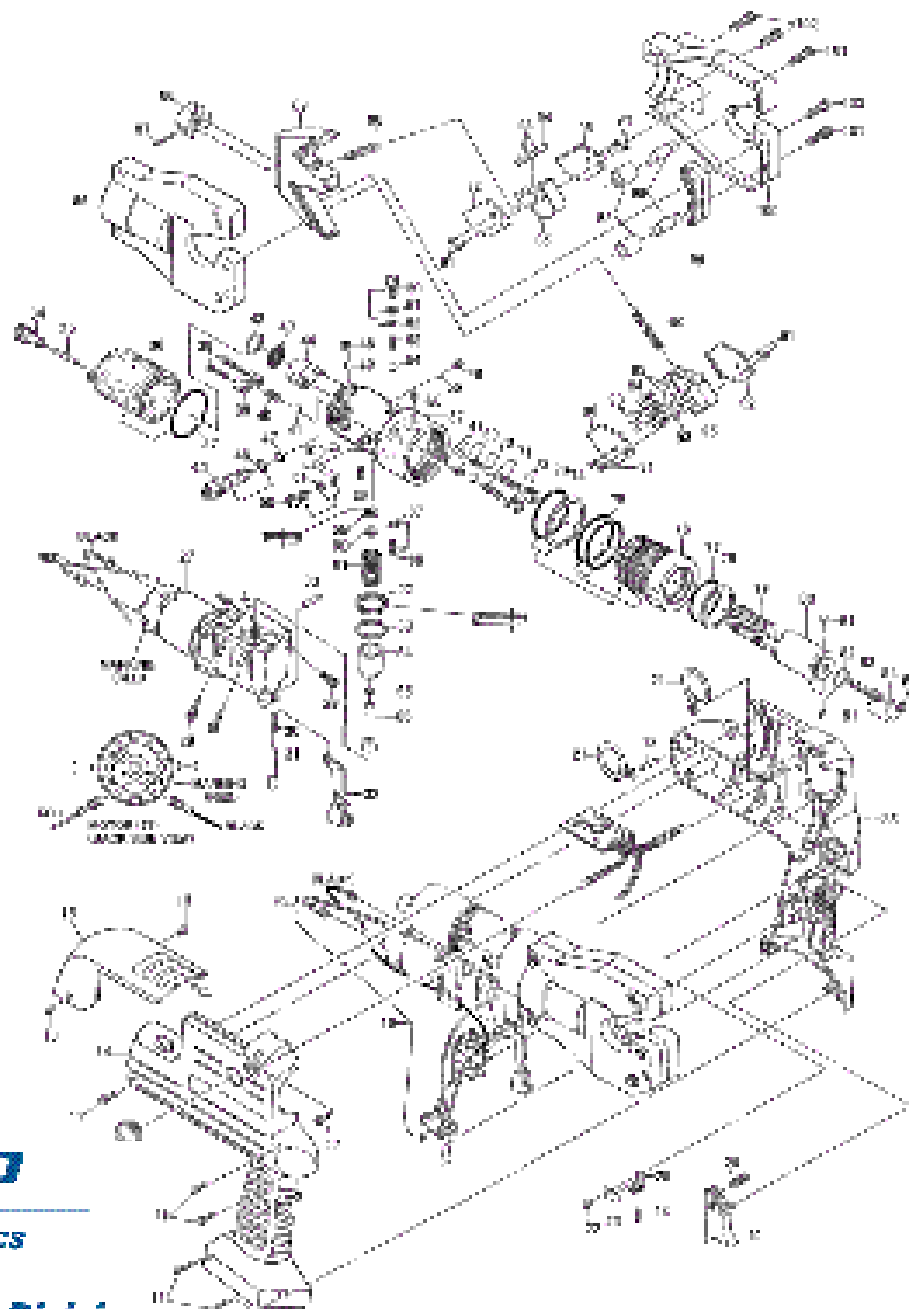

NO.	DESCRIPTION	CODE (QTY)	NO.	DESCRIPTION	CODE (QTY)
11	M4 X 10 Screws	PH500 5	20	PC Back-Up Ring (2.0)	85-01 1
12	Cartridge Cap	PH50-102 1	21	Spring (S/C)	PH50-02 1
13	M4 X 4 Screws	PH50-02 2	22	M4 X 4 Flat Wash	PH50-04 1
14	Washer (S)	PH50-04 1	23	PC Back-Up Ring (3.1)	85-10 1
15	M4 Washer (S)	PH50-04 1	24	Face Plate (H)	PH50-05 1
16	LED Light	PH50-05 1	25	PC O-Ring	58-02 1
17	M4 X 10 Screws	PH50-102 1	26	Face Plate (L)	PH50-06 1
18	4.0 x 1.6 Torx Ball Tip	PH50-07 1	27	PC O-Ring	58-02 1
19	Trigger	PH50-08 1	28	Roller (S) (S/S)	PH50-108 1
20	Spring (M)	PH50-09 1	29	Spring (S)	PH50 2
21	Washer (Ring Term)	PH50-11 2	30	Washer	PH50 2
22	M4 X 4 Screws (T/C)	PH50-04 1	31	Spring (S)	PH50 2
23	Retaining Plate	410-01 1	32	Valve Cores (S)	410-04 2
24	Spring (S/C)	410-02 1	33	PC O-Ring	58-02 1
25	Washer	410-03 1	34	PC Back-Up Ring (S/C)	PH50-01 1
26	Washer (S)	PH50-11 1	35	Washer Ring	108-02 2
27	Washer (S)	PH50-11 1	36	O-Ring	58-10 1
28	Washer (S) (S/C)	PH50-108-0 1	37	Washer Ring	PH50 1
29	Spring (S/C)	PH50-10 1	38	PC Back-Up Ring (S/C)	PH50 1
30	Push Pin	PH50-14 1	39	Face Spring (S/C)	PH50-17 1
31	Retaining Lever	PH50-000 1	40	Face	PH50-18 1
32	2.0 Torx Steel Hex Nut	52-01 1	41	M4 X 4 Washer (S)	PH50 2
33	M4 Washer (S)	PH50-04 1	42	Spring (S)	PH50 1
34	Washer	PH50-05 1	43	M4 Washer (S)	PH50 1
35	O1 Retainer (S)	PH50-04 1	44	PC O-Ring	58-02 1
36	Washer O-Ring	PH50 1	45	PC Back-Up Ring (2.0)	PH50 1
37	M4 X 10 Screws	PH50-102 2	46	Tool Cover (H)	58-10 1
38	Washer (S)	PH50-11 1	47	4.0 x 1.6 Torx Ball Tip	PH50 1
39	Spring (S)	PH50-02 1	48	Tool Cover (L)	PH50 1
40	Washer	PH50 1	49	Tool Cover (S)	PH50 1
41	Washer	PH50 1	50	Slide (S) Spring (S/C)	PH50 2
42	Washer Ring	PH50 2	51	M4 X 4 Screws	PH50 2
43	Washer	PH50 2	52	Slide (S) (S)	PH50 2
44	Washer	PH50 2	53	Roller	PH50-10 10
45	Washer	PH50 2	54	M4 X 4 Screws	PH50 2
46	Washer	PH50 2	55	M4 X 4 Screws	PH50 2
47	Washer	PH50 2	56	Washer (S)	PH50 1
48	Washer	PH50 2	57	Washer (S)	PH50 1
49	Washer	PH50 2	58	Washer (S)	PH50 1
50	Washer	PH50 2	59	Washer (S)	PH50 1
51	Washer	PH50 2	60	Washer (S)	PH50 1
52	Washer	PH50 2	61	Washer (S)	PH50 1
53	Washer	PH50 2	62	Washer (S)	PH50 1
54	Washer	PH50 2	63	Washer (S)	PH50 1
55	Washer	PH50 2	64	Washer (S)	PH50 1
56	Washer	PH50 2	65	Washer (S)	PH50 1
57	Washer	PH50 2	66	Washer (S)	PH50 1
58	Washer	PH50 2	67	Washer (S)	PH50 1
59	Washer	PH50 2	68	Washer (S)	PH50 1
60	Washer	PH50 2	69	Washer (S)	PH50 1
61	Washer	PH50 2	70	Washer (S)	PH50 1
62	Washer	PH50 2	71	Washer (S)	PH50 1
63	Washer	PH50 2	72	Washer (S)	PH50 1
64	Washer	PH50 2	73	Washer (S)	PH50 1
65	Washer	PH50 2	74	Washer (S)	PH50 1
66	Washer	PH50 2	75	Washer (S)	PH50 1
67	Washer	PH50 2	76	Washer (S)	PH50 1
68	Washer	PH50 2	77	Washer (S)	PH50 1
69	Washer	PH50 2	78	Washer (S)	PH50 1
70	Washer	PH50 2	79	Washer (S)	PH50 1
71	Washer	PH50 2	80	Washer (S)	PH50 1
72	Washer	PH50 2	81	Washer (S)	PH50 1
73	Washer	PH50 2	82	Washer (S)	PH50 1
74	Washer	PH50 2	83	Washer (S)	PH50 1
75	Washer	PH50 2	84	Washer (S)	PH50 1
76	Washer	PH50 2	85	Washer (S)	PH50 1
77	Washer	PH50 2	86	Washer (S)	PH50 1
78	Washer	PH50 2	87	Washer (S)	PH50 1
79	Washer	PH50 2	88	Washer (S)	PH50 1
80	Washer	PH50 2	89	Washer (S)	PH50 1
81	Washer	PH50 2	90	Washer (S)	PH50 1
82	Washer	PH50 2	91	Washer (S)	PH50 1
83	Washer	PH50 2	92	Washer (S)	PH50 1
84	Washer	PH50 2	93	Washer (S)	PH50 1
85	Washer	PH50 2	94	Washer (S)	PH50 1
86	Washer	PH50 2	95	Washer (S)	PH50 1
87	Washer	PH50 2	96	Washer (S)	PH50 1
88	Washer	PH50 2	97	Washer (S)	PH50 1
89	Washer	PH50 2	98	Washer (S)	PH50 1
90	Washer	PH50 2	99	Washer (S)	PH50 1
91	Washer	PH50 2	100	Washer (S)	PH50 1
92	Washer	PH50 2	101	Washer (S)	PH50 1
93	Washer	PH50 2	102	Washer (S)	PH50 1
94	Washer	PH50 2	103	Washer (S)	PH50 1
95	Washer	PH50 2	104	Washer (S)	PH50 1
96	Washer	PH50 2	105	Washer (S)	PH50 1
97	Washer	PH50 2	106	Washer (S)	PH50 1
98	Washer	PH50 2	107	Washer (S)	PH50 1
99	Washer	PH50 2	108	Washer (S)	PH50 1
100	Washer	PH50 2	109	Washer (S)	PH50 1
101	Washer	PH50 2	110	Washer (S)	PH50 1
102	Washer	PH50 2	111	Washer (S)	PH50 1
103	Washer	PH50 2	112	Washer (S)	PH50 1
104	Washer	PH50 2	113	Washer (S)	PH50 1
105	Washer	PH50 2	114	Washer (S)	PH50 1
106	Washer	PH50 2	115	Washer (S)	PH50 1
107	Washer	PH50 2	116	Washer (S)	PH50 1
108	Washer	PH50 2	117	Washer (S)	PH50 1
109	Washer	PH50 2	118	Washer (S)	PH50 1
110	Washer	PH50 2	119	Washer (S)	PH50 1
111	Washer	PH50 2	120	Washer (S)	PH50 1
112	Washer	PH50 2	121	Washer (S)	PH50 1
113	Washer	PH50 2	122	Washer (S)	PH50 1
114	Washer	PH50 2	123	Washer (S)	PH50 1
115	Washer	PH50 2	124	Washer (S)	PH50 1
116	Washer	PH50 2	125	Washer (S)	PH50 1
117	Washer	PH50 2	126	Washer (S)	PH50 1
118	Washer	PH50 2	127	Washer (S)	PH50 1
119	Washer	PH50 2	128	Washer (S)	PH50 1
120	Washer	PH50 2	129	Washer (S)	PH50 1
121	Washer	PH50 2	130	Washer (S)	PH50 1
122	Washer	PH50 2	131	Washer (S)	PH50 1
123	Washer	PH50 2	132	Washer (S)	PH50 1
124	Washer	PH50 2	133	Washer (S)	PH50 1
125	Washer	PH50 2	134	Washer (S)	PH50 1
126	Washer	PH50 2	135	Washer (S)	PH50 1
127	Washer	PH50 2	136	Washer (S)	PH50 1
128	Washer	PH50 2	137	Washer (S)	PH50 1
129	Washer	PH50 2	138	Washer (S)	PH50 1
130	Washer	PH50 2	139	Washer (S)	PH50 1
131	Washer	PH50 2	140	Washer (S)	PH50 1
132	Washer	PH50 2	141	Washer (S)	PH50 1
133	Washer	PH50 2	142	Washer (S)	PH50 1
134	Washer	PH50 2	143	Washer (S)	PH50 1
135	Washer	PH50 2	144	Washer (S)	PH50 1
136	Washer	PH50 2	145	Washer (S)	PH50 1
137	Washer	PH50 2	146	Washer (S)	PH50 1
138	Washer	PH50 2	147	Washer (S)	PH50 1
139	Washer	PH50 2	148	Washer (S)	PH50 1
140	Washer	PH50 2	149	Washer (S)	PH50 1
141	Washer	PH50 2	150	Washer (S)	PH50 1
142	Washer	PH50 2	151	Washer (S)	PH50 1
143	Washer	PH50 2	152	Washer (S)	PH50 1
144	Washer	PH50 2	153	Washer (S)	PH50 1
145	Washer	PH50 2	154	Washer (S)	PH50 1
146	Washer	PH50 2	155	Washer (S)	PH50 1
147	Washer	PH50 2	156	Washer (S)	PH50 1
148	Washer	PH50 2	157	Washer (S)	PH50 1
149	Washer	PH50 2	158	Washer (S)	PH50 1
150	Washer	PH50 2	159	Washer (S)	PH50 1
151	Washer	PH50 2	160	Washer (S)	PH50 1
152	Washer	PH50 2	161	Washer (S)	PH50 1
153	Washer	PH50 2	162	Washer (S)	PH50 1
154	Washer	PH50 2	163	Washer (S)	PH50 1
155	Washer	PH50 2	164	Washer (S)	PH50 1
156	Washer	PH50 2	165	Washer (S)	PH50 1
157	Washer	PH50 2	166	Washer (S)	PH50 1
158	Washer	PH50 2	167	Washer (S)	PH50 1
159	Washer	PH50 2	168	Washer (S)	PH50 1
160	Washer	PH50 2	169	Washer (S)	PH50 1
161	Washer	PH50 2	170	Washer (S)	PH50 1
162	Washer	PH50 2	171	Washer (S)	PH50 1
163	Washer	PH50 2	172	Washer (S)	PH50 1
164	Washer	PH50 2	173	Washer (S)	PH50 1
165	Washer	PH50 2	174	Washer (S)	PH50 1
166	Washer	PH50 2	175	Washer (S)	PH50 1
167	Washer	PH50 2	176	Washer (S)	PH50 1
168	Washer	PH50 2	177	Washer (S)	PH50 1
169	Washer	PH50 2	178	Washer (S)	PH50 1
170	Washer	PH50 2	179	Washer (S)	PH50 1
171	Washer	PH50 2	180	Washer (S)	PH50 1
172	Washer	PH50 2	181	Washer (S)	PH50 1
173	Washer	PH50 2	182	Washer (S)	PH50 1
174	Washer	PH50 2	183	Washer (S)	PH50 1
175	Washer	PH50 2	184	Washer (S)	PH50 1
176	Washer	PH50 2	185	Washer (S)	PH50 1
177	Washer	PH50 2	186	Washer (S)	PH50 1
178	Washer	PH50 2	187	Washer (S)	PH50 1
179	Washer	PH50 2	188	Washer (S)	PH50 1
180	Washer	PH50 2	189	Washer (S)	PH50 1
181	Washer	PH50 2	190	Washer (S)	PH50 1
182	Washer	PH50 2	191	Washer (S)	PH50 1
183	Washer	PH50 2	192	Washer (S)	PH50 1
184	Washer	PH50 2	193	Washer (S)	PH50 1
185	Washer	PH50 2	194	Washer (S)	PH50 1
186	Washer	PH50 2	195	Washer (S)	PH50 1
187	Washer	PH50 2	196	Washer (S)	PH50 1
188	Washer	PH50 2	197	Washer (S)	PH50 1
189	Washer	PH50 2	198	Washer (S)	PH50 1
190	Washer	PH50 2	199	Washer (S)	PH50 1
191	Washer	PH50 2	200	Washer (S)	PH50 1



UTILUX | SPARE PARTS LIST

Product - #98ROBO

Description - Heavy Duty Battery Operated Hydraulic Crimping Tool

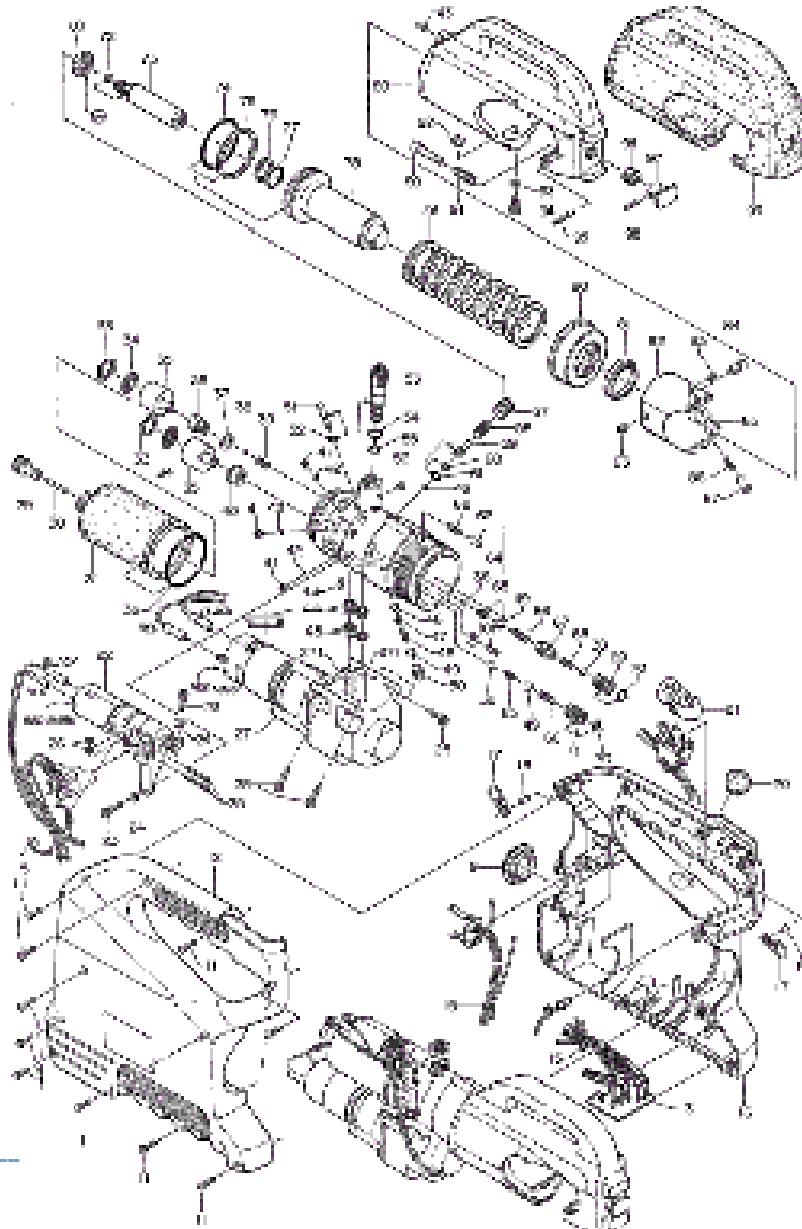

NO.	DESCRIPTION	CODE	QTY	NO.	DESCRIPTION	CODE	QTY
11	PHX 15 Screw	PHX09	18	20	P-4 Back-Up Ring (2.0)	PH420	1
12	Washer (2)	15-01	1	21	P-4 O-Ring	PH420	1
13	Control Nut	207-10	1	22	Spring (7.5)	PH170	1
14	Washer	PH421	1	23	Washer (1.5)	PH170	1
15	Washer (3)	207-10	1	24	Washer	PH170	1
17	Hanging Ring Assy	PH0-12HA	2	25	Spring (2)	PH40	2
18	4 (1/2) Parallel Pin	15-04	2	26	Spring (2)	PH40	2
19	Oil Feed Cap	15-05	1	27	Valve Screw (2)	PH140	1
21	O-Ring (1.5)	PH410	1	28	Spring (1.5)	PH170	1
21	Control Nut	207-10	1	29	Valve (1.5) (2)	PH170	1
22	Washer (1.5)	207-10	1	30	PH1 O-Ring	PH40	1
23	PHX 10 Screw	15-03	2	31	Valve Screw (1)	PH0440	1
24	PH Flat Washer	16-01	2	32	O-Ring	PH40	1
25	PH 1/4 20 Screw	PH0-02	2	33	Linear Pin	PH1214	1
26	PH 1/4 Lock Nut	PH0022	2	34	PH O-Ring	PH0020	1
27	Washer (1)	207-10	1	35	PH 1/2 Wash-Less Ring (3.0)	PH430	1
29	PH 1/2 20 Screw (2)	PH01204	4	36	PH 1/2 Wash-Less Ring (3.0)	PH430	1
28	Washer (2)	PH100	1	37	PH O-Ring	PH40	1
30	Integral	PH0-02	1	38	Ram	PH1402	1
31	Oil Feed Cap (2)	15-05	1	39	Ram Spring (1.4)	PH140	1
32	P-4 O-Ring	PH0027	1	40	Guide Ring	PH140	1
33	PH 20 Hex	PH100	2	41	PH 20 Hex (2)	PH0100	1
34	PH Hex (1)	PH100	2	42	PH Hex (1)	PH1000	1
35	PH Hex	PH400	2	43	PH 1/2 Hex (1.5)	PH0100	2
36	Galvan Coating (1)	15-11	1	44	PH 1/2 Hex (1.5)	PH0100	2
37	Cooper Galval (2)	PH0047	1	45	PH 1/2 Hex (1.5)	PH0100	1
38	PH O-Ring	PH40	1	46	PH 1/2 Hex (1.5)	PH0100	1
39	Spring (1.5)	PH170	1	47	PH 1/2 Hex (1.5)	PH0100	1
40	PH Hex (1.5) (1)	PH0100	1	48	PH Hex (1.5)	PH0100	1
41	PH 1/2 Hex (1.5)	PH0100	1	49	PH Hex (1.5)	PH0100	1
42	PH O-Ring	PH40	1	50	Spring (2.5)	PH040	1
43	PH 1/2 Hex (1.5)	PH0100	2	51	Key	PH0400	1
44	PH 1/2 Hex (1.5)	PH0100	2	52	PH 1/2 Hex (1.5) (2)	PH0100	1
45	PH 1/2 Hex (1.5) (2)	PH0100	2	53	Guide Cover	PH0410	1
46	PH O-Ring	PH40	1	54	PH 1/2 Hex (1.5) (2)	PH0100	1
47	PH 1/2 Hex (1.5)	PH0100	1	55	Hex (1.5)	PH0100	1
48	Spring (1.5)	PH170	1	56	PH 1/2 Hex (1.5)	PH0100	1
49	PH O-Ring	PH40	1	57	PH 1/2 Hex (1.5) (2)	PH0100	1
50	PH 1/2 Hex (1.5) (2)	PH0100	1	58	Head Insulation	PH0030	1
51	PH Hex (1.5)	PH0100	1	59	Stripper Mat	PH100	1
52	PH O-Ring	PH40	1	60	PH 1/2 Hex (1.5)	PH0100	1
53	PH 1/2 Hex (1.5)	PH0100	1	61	PH 1/2 Hex (1.5)	PH0100	2
54	PH O-Ring (2)	PH0040	1				
55	PH X 10 Screw	PH0-10	1				
57	Valve Screw (1)	15-10	1				
58	Spring (1.5)	207-10	1				
59	Reduction Valve	15-10	1				



UTILUX | SPARE PARTS LIST

Product - #REC 50U

Description - Battery Operated Cable Cutter

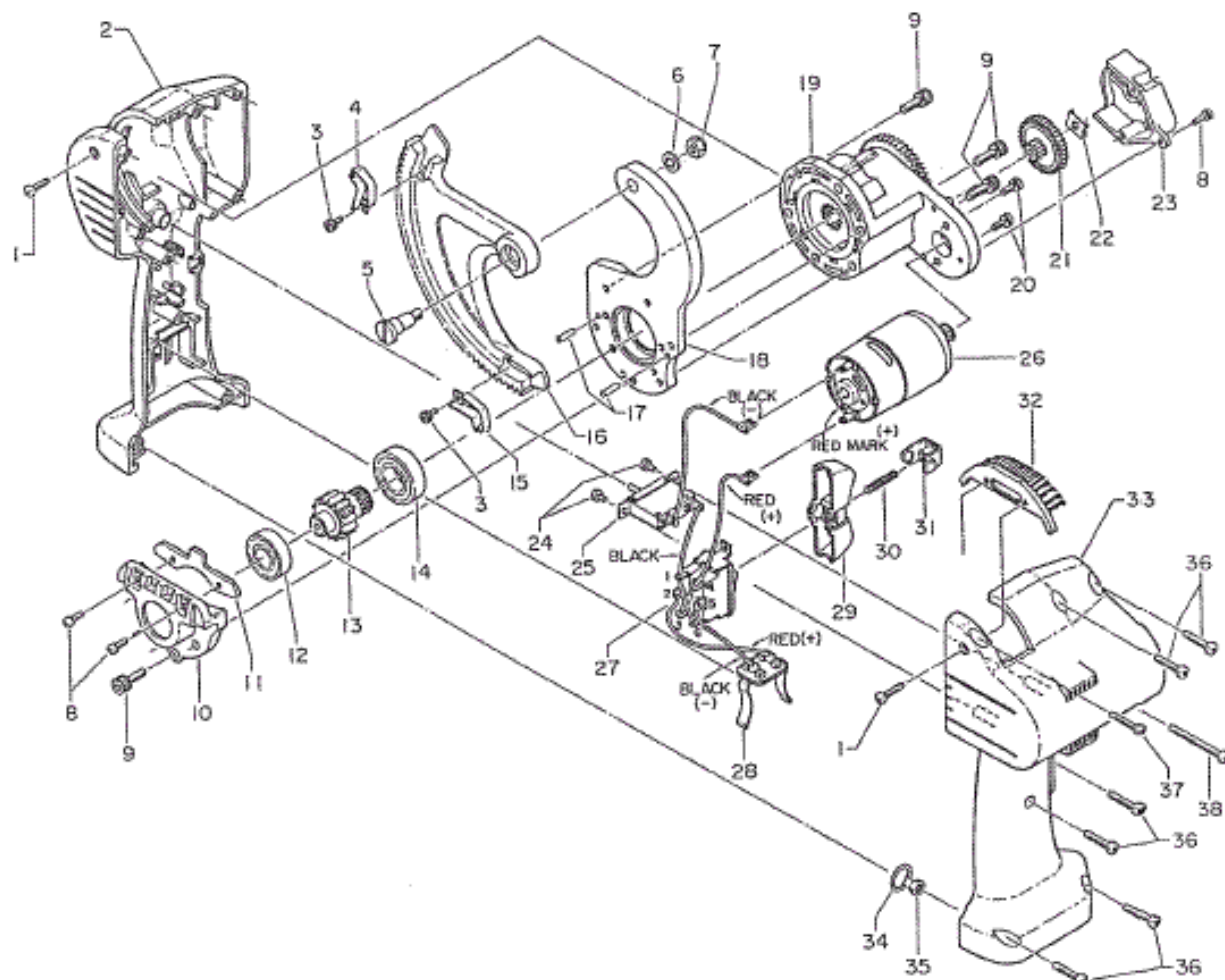

NO.	DESCRIPTION	CODE	QTY
1	POX 10 Screw (T.F.)	TS00-01	2
2	Bracket (L)	TS00-02	-
3	POX 10 Screw	TS00-03	2
4	Flange Washer (R)	TS00-04	-
5	Bracket (Rear)	TS00-05	-
6	POX Lock Washer (HL)	TS00-06	-
7	POX Lock Nut	TS00-07	-
8	POX 10 Screw	TS00-08	5
9	POX 10 Screw	TS00-09	13
10	Bracket (L)	TS00-10	-
11	POX 10 Screw	TS00-11	-
12	Bracket (R)	TS00-12	-
13	POX 10 Screw	TS00-13	-
14	Bracket (R)	TS00-14	-
15	Bracket (L)	TS00-15	-
16	Bracket (R)	TS00-16	-
17	Bracket (L)	TS00-17	-
18	Bracket (R)	TS00-18	-
19	Motor	TS00-19	-
20	POX 10 Screw	TS00-20	-
21	POX 10 Screw	TS00-21	-
22	POX 10 Screw	TS00-22	-
23	POX 10 Screw	TS00-23	-
24	POX 10 Screw	TS00-24	-
25	POX 10 Screw	TS00-25	-
26	POX 10 Screw	TS00-26	-
27	POX 10 Screw	TS00-27	-
28	POX 10 Screw	TS00-28	-
29	POX 10 Screw	TS00-29	-
30	POX 10 Screw	TS00-30	-
31	POX 10 Screw	TS00-31	-
32	POX 10 Screw	TS00-32	-
33	POX 10 Screw	TS00-33	-
34	POX 10 Screw	TS00-34	-
35	POX 10 Screw	TS00-35	-
36	POX 10 Screw	TS00-36	-
37	POX 10 Screw	TS00-37	-
38	POX 10 Screw	TS00-38	-

tyco

Electronics

Energy Division



UTILUX | SPARE PARTS LIST

Product - #CCSP55

Description - Hydraulic Cable Cutter Head

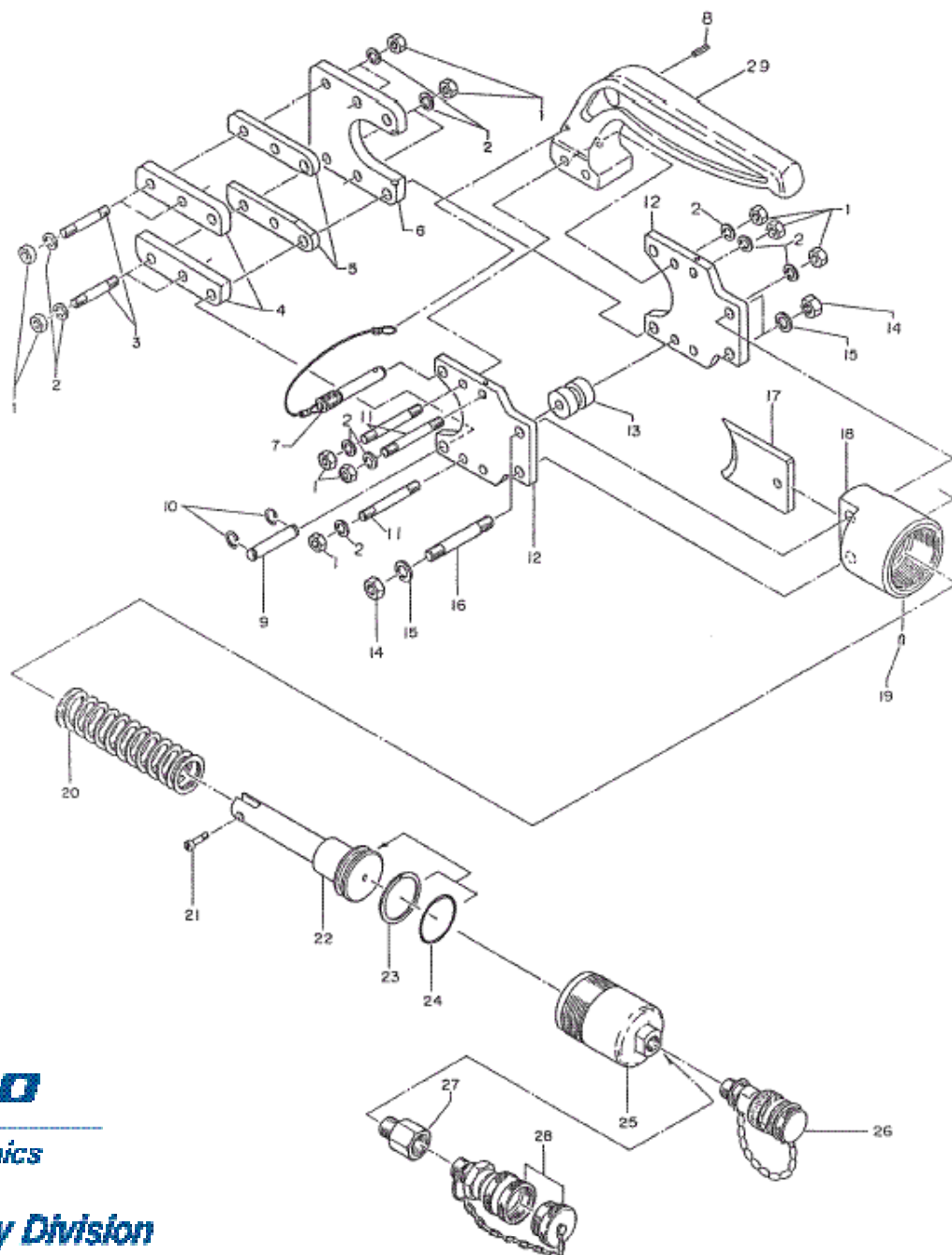

NO	DESCRIPTION	QTY	UNIT
1	WIP - Seal Kit	4121	14
2	WIP - Seal Wiper	4121	14
3	Glid Bolt (C)	1541	4
4	Lead Shear Pin	1542	2
5	Spacer	1543	2
6	WIP - Seal Kit	4121	-
7	WIP - Seal Kit	4121	-
8	WIP - Seal Kit (P/A)	4121	-
9	Pin (K)	1540	-
10	WIP - Seal Kit (P/B)	4121	2
11	Glid Bolt (C)	1541	3
12	WIP - Seal Kit	4121	2
13	WIP - Seal Kit	4121	-
14	WIP - Seal Kit	4121	-
15	WIP - Seal Kit	4121	-
16	WIP - Seal Kit	4121	-
17	WIP - Seal Kit	4121	-
18	WIP - Seal Kit	4121	-
19	WIP - Seal Kit	4121	-
20	WIP - Seal Kit	4121	-
21	WIP - Seal Kit	4121	-
22	WIP - Seal Kit	4121	-
23	WIP - Seal Kit	4121	-
24	WIP - Seal Kit	4121	-
25	WIP - Seal Kit	4121	-
26	WIP - Seal Kit	4121	-
27	WIP - Seal Kit	4121	-
28	WIP - Seal Kit	4121	-

tyco

Electronics

Energy Division



UTILUX | SPARE PARTS LIST

Product - #CCSP100

Description - Hydraulic Cable Cutter Head

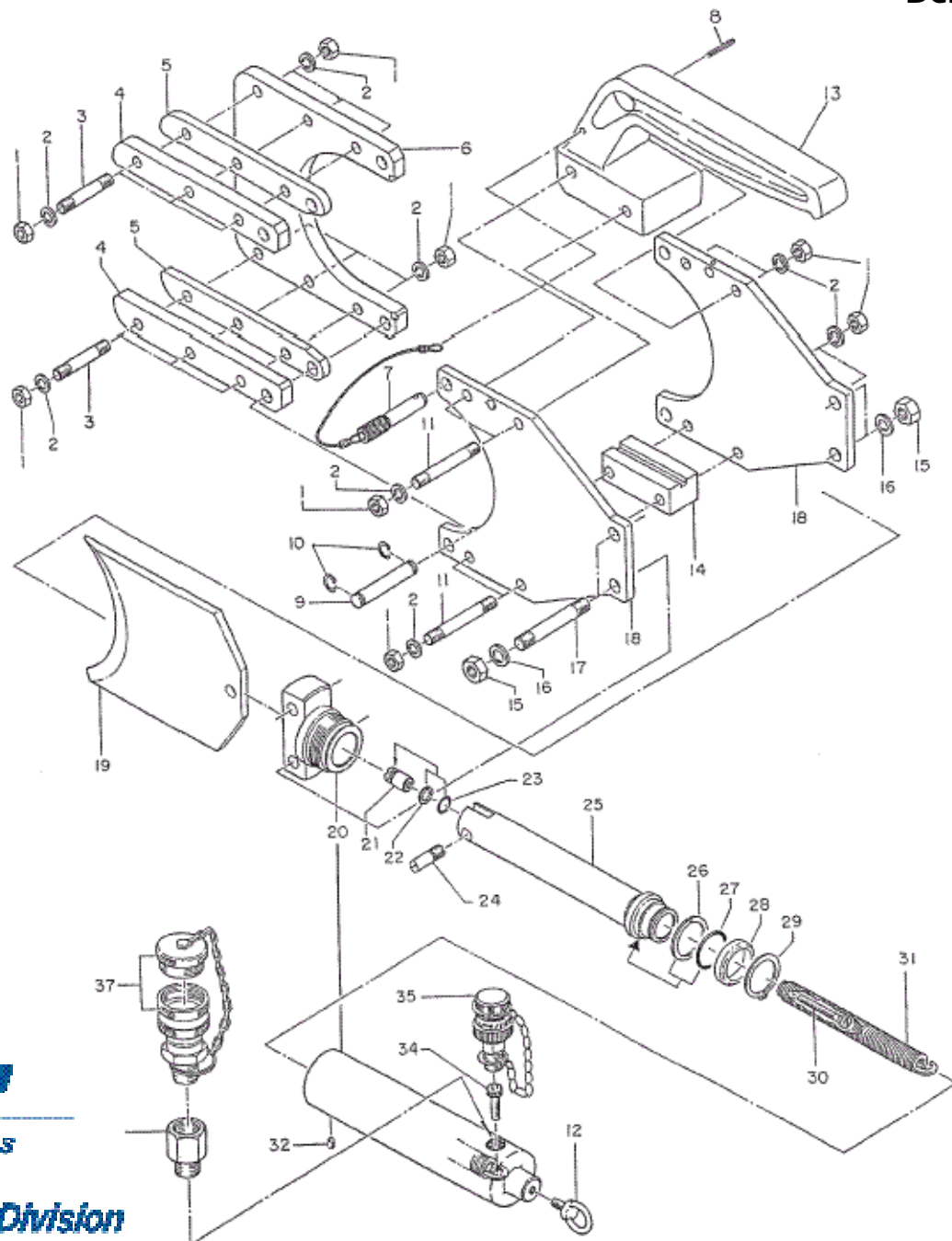

NO.	DESCRIPTION	CODE	QTY
1	Pin C - sec.Nuc	40-21	20
2	Pin C - Lock Washer	40-22	20
3	Pin C - Bolt (10)	40-17	4
4	Pin C - Bolt (10)	40-17	2
5	Pin C - Bolt (10)	40-17	2
6	Head Shear	100-01	-
7	Lock Pin Assy	100-01	-
8	Pin C - Drive Pin (40)	100-02	-
9	Pin C - Bolt	40-15	-
10	Pin C - Bolt (10)	40-17	2
11	Pin C - Bolt (10)	40-17	2
12	Pin C - Bolt (10)	40-17	2
13	Pin C - Bolt (10)	40-17	2
14	Pin C - Bolt (10)	40-17	2
15	Pin C - Bolt (10)	40-17	2
16	Pin C - Bolt (10)	40-17	2
17	Pin C - Bolt (10)	40-17	2
18	Pin C - Bolt (10)	40-17	2
19	Pin C - Bolt (10)	40-17	2
20	Pin C - Bolt (10)	40-17	2
21	Pin C - Bolt (10)	40-17	2
22	Pin C - Bolt (10)	40-17	2
23	Pin C - Bolt (10)	40-17	2
24	Pin C - Bolt (10)	40-17	2
25	Pin C - Bolt (10)	40-17	2
26	Pin C - Bolt (10)	40-17	2
27	Pin C - Bolt (10)	40-17	2
28	Pin C - Bolt (10)	40-17	2
29	Pin C - Bolt (10)	40-17	2
30	Pin C - Bolt (10)	40-17	2
31	Pin C - Bolt (10)	40-17	2
32	Pin C - Bolt (10)	40-17	2
33	Pin C - Bolt (10)	40-17	2
34	Pin C - Bolt (10)	40-17	2
35	Pin C - Bolt (10)	40-17	2
36	Pin C - Bolt (10)	40-17	2
37	Pin C - Bolt (10)	40-17	2

tyco

Electronics

Energy Division



UTILUX | SPARE PARTS LIST

Product - #CCS20A
Description - Hand Operated Hydraulic Cable Cutter

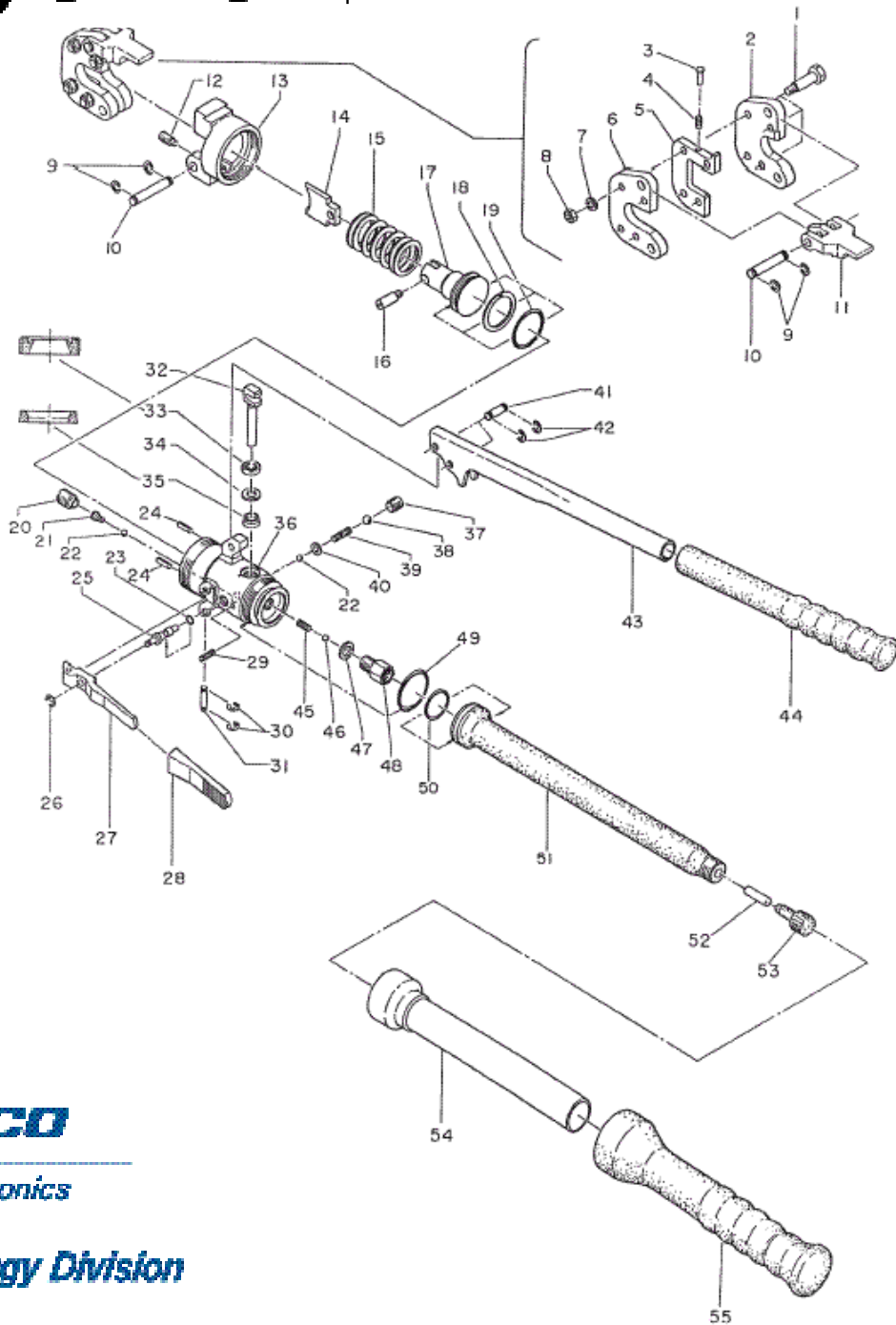

NO.	DESCRIPTION	CODE	QTY	NO.	DESCRIPTION	CODE	QTY
1	Shank Seal Bolt	10-000	4	49	3-16 O-Ring	00-0	1
2	Head Gasket	20-00	1	50	7-16 O-Ring	10-00	1
3	Pin (1/8")	20-01	1	51	Ball Race (with Grip)	100-000	1
4	Pin (1/8")	20-01	1	52	Mag. Nut	40-0-00	1
5	Pin (1/8")	20-01	1	53	Hex Nut with Grip	20-0-00	1
6	Mini Head	20-04	1	54	Body Handle	10-00	1
7	MC Lock Washer	10-00	4	55	Body Handle Grip	00-1	1
8	MC Lock Nut	10-01	4				
9	Pin (1/8")	20-01	1				
10	Pin (1/8")	20-01	1				
11	Pin (1/8")	20-01	1				
12	Pin (1/8")	20-01	1				
13	Pin (1/8")	20-01	1				
14	Pin (1/8")	20-01	1				
15	Pin (1/8")	20-01	1				
16	Pin (1/8")	20-01	1				
17	Pin (1/8")	20-01	1				
18	Pin (1/8")	20-01	1				
19	Pin (1/8")	20-01	1				
20	Pin (1/8")	20-01	1				
21	Pin (1/8")	20-01	1				
22	Pin (1/8")	20-01	1				
23	Pin (1/8")	20-01	1				
24	Pin (1/8")	20-01	1				
25	Pin (1/8")	20-01	1				
26	Pin (1/8")	20-01	1				
27	Pin (1/8")	20-01	1				
28	Pin (1/8")	20-01	1				
29	Pin (1/8")	20-01	1				
30	Pin (1/8")	20-01	1				
31	Pin (1/8")	20-01	1				
32	Pin (1/8")	20-01	1				
33	Pin (1/8")	20-01	1				
34	Pin (1/8")	20-01	1				
35	Pin (1/8")	20-01	1				
36	Pin (1/8")	20-01	1				
37	Pin (1/8")	20-01	1				
38	Pin (1/8")	20-01	1				
39	Pin (1/8")	20-01	1				
40	Pin (1/8")	20-01	1				
41	Pin (1/8")	20-01	1				
42	Pin (1/8")	20-01	1				
43	Pin (1/8")	20-01	1				
44	Pin (1/8")	20-01	1				
45	Pin (1/8")	20-01	1				
46	Pin (1/8")	20-01	1				
47	Pin (1/8")	20-01	1				
48	Pin (1/8")	20-01	1				
49	Pin (1/8")	20-01	1				
50	Pin (1/8")	20-01	1				
51	Pin (1/8")	20-01	1				
52	Pin (1/8")	20-01	1				
53	Pin (1/8")	20-01	1				
54	Pin (1/8")	20-01	1				
55	Pin (1/8")	20-01	1				



UTILUX | SPARE PARTS LIST

Product - #CCS40A

Description - Hand Operated Hydraulic Cable Cutter

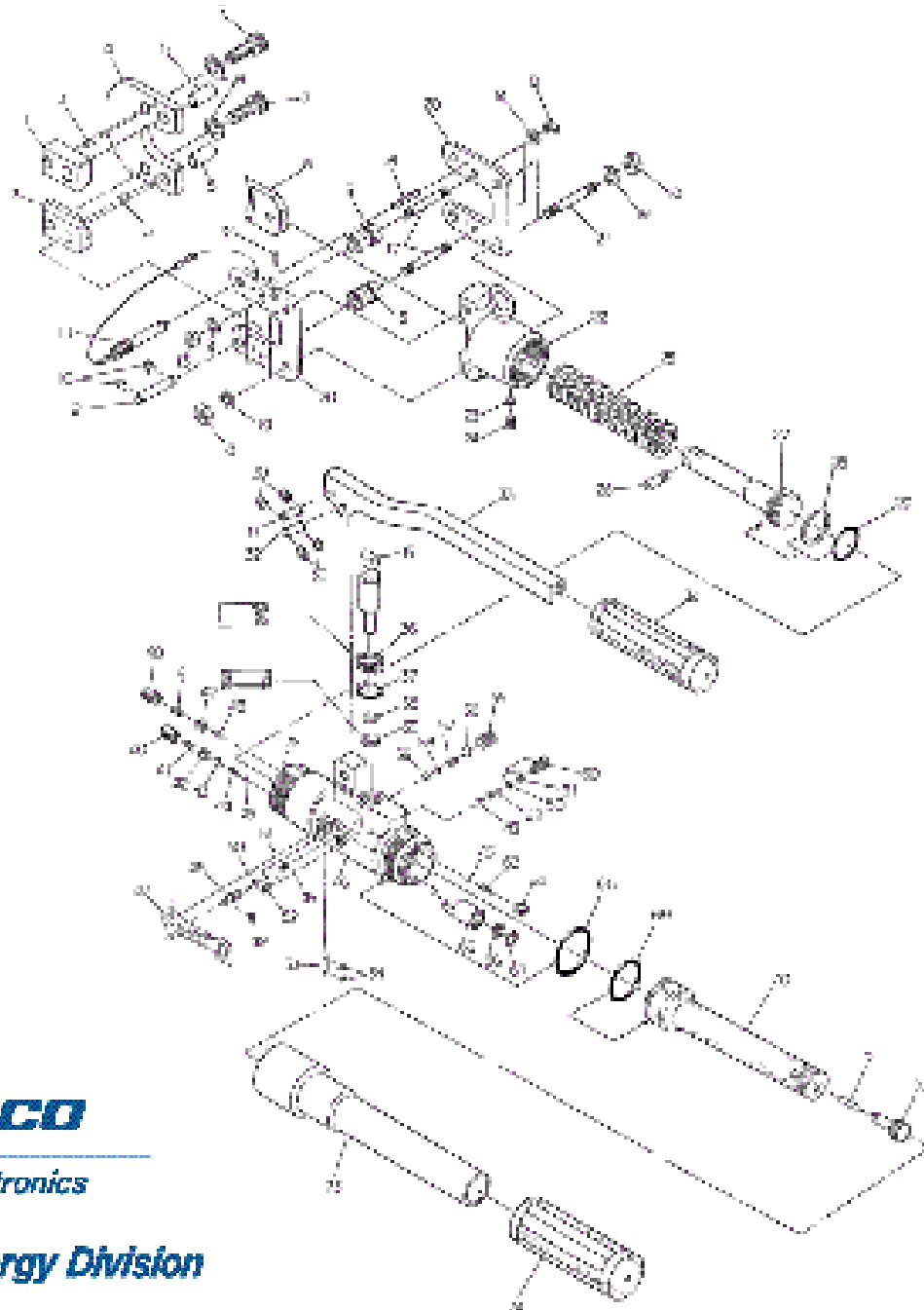

NO.	DESCRIPTION	CODE	QTY	NO.	DESCRIPTION	CODE	QTY
1	Graze Pin (A)	46-02	1	46	O-Ring Snap Ring	15-20	1
2	Graze Pin (B)	46-04	1	50	O-Ring (O-R)	30-27	2
3	30X12 Drive Pin (A)	46-06	2	61	Pin (P)	41-17	1
4	Head Pin	46-07	1	62	M8 EA Pin (P)	40-14	1
5	Pin (A)	46-12	2	63	Pin (P)	18-07	1
6	M12 Lock Washer	46-08	2	64	O-Ring Snap Ring	15-20	2
7	M12X30 Screw	46-11	2	65	M8 X 1.2 Screw (T,P)	40-47	1
8	Blade	46-14	1	66	W12/2 Seal	15-40	1
9	Pin (A)	46-18	1	67	Pin (P)	18-08	1
10	12X12 Pin (A)	46-19	2	68	M8 Flat Washer	18-06	1
11	Lock Pin (A)	46-17	1	69	Pin (P)	18-08	1
12	30X12 Drive Pin (A)	46-06	1	70	Ring	003-17	1
13	M8 Hex Nut	46-24	4	71	O-Ring Snap Ring (O-R)	91-30	1
14	M8 Lock Washer	46-25	4	72	Spring (S)	003-19	1
15	Roller	46-27	2	73	Spring (S)	003-20	1
16	30X12 Drive Pin (A)	46-06	1	74	Roller Washer (P)	003-17	1
17	Pin (A)	46-18	2	75	Pin (P)	003-10	1
18	M8 Hex Nut	46-24	4	76	Roller	003-18	1
19	M8 Lock Washer	46-25	4	77	O-Ring Ring	003-26	1
20	Support Flare	46-34	2	78	O-Ring O-Ring	003-25	1
21	Steel Bolt (B)	46-36	2	79	O-Ring O-Ring	003-21	1
22	Roller Wheel	46-37	1	80	Roller Wheel (P)	20K-11	1
23	M8 Lock Washer	46-25	1	81	Ring (P)	404-26	1
24	Pin (A)	46-18	1	82	Roller Wheel Grip	37E-18	1
25	Roller Spring (S)	46-38	1	83	Body Handle Assy	400-01	1
26	Blade Screw	46-40	1	84	Body Handle Grip	400-00	1
27	Roller	46-42	1	85	25X113 O-Ring (P)	400-01	2
28	Pin (A)	46-18	1				
29	Pin (A)	46-18	1				
30	12X12 Pin (A)	46-19	4				
31	Pin (B)	003-08	1				
32	Pin (B)	003-07	1				
33	Pump Handle	400-01	1				
34	Pump Handle Grip	400-00	1				
35	Pump Pin (A)	04E-15	1				
36	Pin (B)	04E-11	1				
37	Pin (B)	04E-12	1				
38	M8 Lock Washer (P)	40-14	1				
39	O-Ring Snap Ring (O-R)	15-40	1				
40	Roller Wheel Seal	15-40	1				
41	Roller Wheel Seal	20C-11	2				
42	Pin (B)	003-21	2				
43	Pin (B)	003-20	2				
44	Roller Wheel	18-08	2				
45	Spring (S)	003-20	1				
46	Roller Wheel	46-28	2				
47	Body	400-00	1				
48	Roller Wheel Seal	20E-18	1				
49	Roller Wheel Seal	400-00	1				

tyco

Electronics

Energy Division

All of the above information, including drawings, illustrations and graphic designs, reflects our present understanding and is to the best of our knowledge and belief correct and reliable. Users, however, should independently evaluate the suitability of each product for the desired application. Under no circumstances does this constitute an assurance of any particular quality or performance. Such an assurance is only provided in the context of our product specifications or explicit contractual arrangements. Our liability for these products is set forth in our standard terms and conditions of sale. ALR, AMP, AXICOM, B&H, BOWTHORPE EMP, CROMPTON INSTRUMENTS, DORMAN SMITH, DULMISON, GURO, HELLSTERN, IDENTO, LA PRAIRIE, MORLYNN, RAYCHEM, and SIMEL are trademarks.

tyco**Electronics****Energy Division****Argentina**Phone: 54-11-4733 2277
Fax: 54-11-4733-2267**Australia**Phone: 61-2-4390 1111
Fax: 61-2-4353 2497**Brazil**Phone: 55-11-861 1311
Fax: 55-11-861 1862**Canada**Phone: 1-905-475 6222
Fax: 1-905-470 4453**France**Phone: 33-3-8058 3200
Fax: 33-3-8034 1015**Mexico**Phone: 52-5-729 0405
Fax: 52-5-361 8545**Thailand**Phone: 66-2-7394026-32
Fax: 66-2-3260563-64**USA**Phone: 1-800-327 6996
Fax: 1-800-527 8350

**Tyco Electronics
Energy Division**Dulmison Pty Limited A.B.N. 56 000 129 573
PO Box 156, Wyong NSW 2259 Australia
Phone: 61-2-4390 1111 Fax: 61-2-4353 2497www.energy.tycoelectronics.com



UTILUX



UTILUX



UTILUX



UTILUX



UTILUX



UTILUX



UTILUX



UTILUX

